



Sun™ XVR-1200 Graphics Accelerator Installation and User's Guide

Sun Microsystems, Inc.
www.sun.com

Part No. 816-7386-12
July 2004, Revision A

Submit comments about this document at: <http://www.sun.com/hwdocs/feedback>

Copyright 2004 Sun Microsystems, Inc., 4150 Network Circle, Santa Clara, California 95054, U.S.A. All rights reserved.

Sun Microsystems, Inc. has intellectual property rights relating to technology embodied in the product that is described in this document. In particular, and without limitation, these intellectual property rights may include one or more of the U.S. patents listed at <http://www.sun.com/patents> and one or more additional patents or pending patent applications in the U.S. and in other countries.

This document and the product to which it pertains are distributed under licenses restricting their use, copying, distribution, and decompilation. No part of the product or of this document may be reproduced in any form by any means without prior written authorization of Sun and its licensors, if any.

Third-party software, including font technology, is copyrighted and licensed from Sun suppliers.

Parts of the product may be derived from Berkeley BSD systems, licensed from the University of California. UNIX is a registered trademark in the U.S. and in other countries, exclusively licensed through X/Open Company, Ltd.

Sun, Sun Microsystems, the Sun logo, Sun Blade, Sun Fire, docs.sun.com, and Solaris are trademarks or registered trademarks of Sun Microsystems, Inc. in the U.S. and in other countries.

All SPARC trademarks are used under license and are trademarks or registered trademarks of SPARC International, Inc. in the U.S. and in other countries. Products bearing SPARC trademarks are based upon an architecture developed by Sun Microsystems, Inc.

The OPEN LOOK and Sun™ Graphical User Interface was developed by Sun Microsystems, Inc. for its users and licensees. Sun acknowledges the pioneering efforts of Xerox in researching and developing the concept of visual or graphical user interfaces for the computer industry. Sun holds a non-exclusive license from Xerox to the Xerox Graphical User Interface, which license also covers Sun's licensees who implement OPEN LOOK GUIs and otherwise comply with Sun's written license agreements. OpenGL is a registered trademark of Silicon Graphics, Inc.

Use, duplication, or disclosure by the U.S. Government is subject to restrictions set forth in the Sun Microsystems, Inc. license agreements and as provided in DFARS 227.7202-1(a) and 227.7202-3(a) (1995), DFARS 252.227-7013(c)(1)(ii) (Oct. 1998), FAR 12.212(a) (1995), FAR 52.227-19, or FAR 52.227-14 (ALT III), as applicable.

DOCUMENTATION IS PROVIDED "AS IS" AND ALL EXPRESS OR IMPLIED CONDITIONS, REPRESENTATIONS AND WARRANTIES, INCLUDING ANY IMPLIED WARRANTY OF MERCHANTABILITY, FITNESS FOR A PARTICULAR PURPOSE OR NON-INFRINGEMENT, ARE DISCLAIMED, EXCEPT TO THE EXTENT THAT SUCH DISCLAIMERS ARE HELD TO BE LEGALLY INVALID.

Copyright 2004 Sun Microsystems, Inc., 4150 Network Circle, Santa Clara, California 95054, Etats-Unis. Tous droits réservés.

Sun Microsystems, Inc. a les droits de propriété intellectuelle relatifs à la technologie incorporée dans le produit qui est décrit dans ce document. En particulier, et sans limitation, ces droits de propriété intellectuelle peuvent inclure un ou plus des brevets américains énumérés à <http://www.sun.com/patents> et un ou les brevets plus supplémentaires ou les applications de brevet en attente dans les Etats-Unis et dans les autres pays.

Ce produit ou document est protégé par un copyright et distribué avec des licences qui en restreignent l'utilisation, la copie, la distribution, et la décompilation. Aucune partie de ce produit ou document ne peut être reproduite sous aucune forme, par quelque moyen que ce soit, sans l'autorisation préalable et écrite de Sun et de ses bailleurs de licence, s'il y en a.

Le logiciel détenu par des tiers, et qui comprend la technologie relative aux polices de caractères, est protégé par un copyright et licencié par des fournisseurs de Sun.

Des parties de ce produit pourront être dérivées des systèmes Berkeley BSD licenciés par l'Université de Californie. UNIX est une marque déposée aux Etats-Unis et dans d'autres pays et licenciée exclusivement par X/Open Company, Ltd.

Sun, Sun Microsystems, le logo Sun, Sun Blade, Sun Fire., docs.sun.com, et Solaris sont des marques de fabrique ou des marques déposées de Sun Microsystems, Inc. aux Etats-Unis et dans d'autres pays.

Toutes les marques SPARC sont utilisées sous licence et sont des marques de fabrique ou des marques déposées de SPARC International, Inc. aux Etats-Unis et dans d'autres pays. Les produits portant les marques SPARC sont basés sur une architecture développée par Sun Microsystems, Inc.

L'interface d'utilisation graphique OPEN LOOK et Sun™ a été développée par Sun Microsystems, Inc. pour ses utilisateurs et licenciés. Sun reconnaît les efforts de pionniers de Xerox pour la recherche et le développement du concept des interfaces d'utilisation visuelle ou graphique pour l'industrie de l'informatique. Sun détient une licence non exclusive de Xerox sur l'interface d'utilisation graphique Xerox, cette licence couvrant également les licenciés de Sun qui mettent en place l'interface d'utilisation graphique OPEN LOOK et qui en outre se conforment aux licences écrites de Sun. OpenGL est une marque déposée de Silicon Graphics, Inc.

LA DOCUMENTATION EST FOURNIE "EN L'ÉTAT" ET TOUTES AUTRES CONDITIONS, DECLARATIONS ET GARANTIES EXPRESSES OU TACITES SONT FORMELLEMENT EXCLUES, DANS LA MESURE AUTORISÉE PAR LA LOI APPLICABLE, Y COMPRIS NOTAMMENT TOUTE GARANTIE IMPLICITE RELATIVE A LA QUALITE MARCHANDE, A L'APTITUDE A UNE UTILISATION PARTICULIERE OU A L'ABSENCE DE CONTREFAÇON.

LA DOCUMENTATION EST FOURNIE "EN L'ÉTAT" ET TOUTES AUTRES CONDITIONS, DECLARATIONS ET GARANTIES EXPRESSES OU TACITES SONT FORMELLEMENT EXCLUES, DANS LA MESURE AUTORISÉE PAR LA LOI APPLICABLE, Y COMPRIS NOTAMMENT TOUTE GARANTIE IMPLICITE RELATIVE A LA QUALITE MARCHANDE, A L'APTITUDE A UNE UTILISATION PARTICULIERE OU A L'ABSENCE DE CONTREFAÇON.



Regulatory Compliance Statements

Your Sun product is marked to indicate its compliance class:

- Federal Communications Commission (FCC) — USA
- Industry Canada Equipment Standard for Digital Equipment (ICES-003) — Canada
- Voluntary Control Council for Interference (VCCI) — Japan
- Bureau of Standards Metrology and Inspection (BSMI) — Taiwan

Please read the appropriate section that corresponds to the marking on your Sun product before attempting to install the product.

FCC Class A Notice

This device complies with Part 15 of the FCC Rules. Operation is subject to the following two conditions:

1. This device may not cause harmful interference.
2. This device must accept any interference received, including interference that may cause undesired operation.

Note: This equipment has been tested and found to comply with the limits for a Class A digital device, pursuant to Part 15 of the FCC Rules. These limits are designed to provide reasonable protection against harmful interference when the equipment is operated in a commercial environment. This equipment generates, uses, and can radiate radio frequency energy, and if it is not installed and used in accordance with the instruction manual, it may cause harmful interference to radio communications. Operation of this equipment in a residential area is likely to cause harmful interference, in which case the user will be required to correct the interference at his own expense.

Shielded Cables: Connections between the workstation and peripherals must be made using shielded cables to comply with FCC radio frequency emission limits. Networking connections can be made using unshielded twisted-pair (UTP) cables.

Modifications: Any modifications made to this device that are not approved by Sun Microsystems, Inc. may void the authority granted to the user by the FCC to operate this equipment.

FCC Class B Notice

This device complies with Part 15 of the FCC Rules. Operation is subject to the following two conditions:

1. This device may not cause harmful interference.
2. This device must accept any interference received, including interference that may cause undesired operation.

Note: This equipment has been tested and found to comply with the limits for a Class B digital device, pursuant to Part 15 of the FCC Rules. These limits are designed to provide reasonable protection against harmful interference in a residential installation. This equipment generates, uses and can radiate radio frequency energy and, if not installed and used in accordance with the instructions, may cause harmful interference to radio communications. However, there is no guarantee that interference will not occur in a particular installation. If this equipment does cause harmful interference to radio or television reception, which can be determined by turning the equipment off and on, the user is encouraged to try to correct the interference by one or more of the following measures:

- Reorient or relocate the receiving antenna.
- Increase the separation between the equipment and receiver.
- Connect the equipment into an outlet on a circuit different from that to which the receiver is connected.
- Consult the dealer or an experienced radio/television technician for help.

Shielded Cables: Connections between the workstation and peripherals must be made using shielded cables in order to maintain compliance with FCC radio frequency emission limits. Networking connections can be made using unshielded twisted pair (UTP) cables.

Modifications: Any modifications made to this device that are not approved by Sun Microsystems, Inc. may void the authority granted to the user by the FCC to operate this equipment.

ICES-003 Class A Notice - Avis NMB-003, Classe A

This Class A digital apparatus complies with Canadian ICES-003.

Cet appareil numérique de la classe A est conforme à la norme NMB-003 du Canada.

ICES-003 Class B Notice - Avis NMB-003, Classe B

This Class B digital apparatus complies with Canadian ICES-003.

Cet appareil numérique de la classe B est conforme à la norme NMB-003 du Canada.

VCCI 基準について

クラス A VCCI 基準について

クラス A VCCI の表示があるワークステーションおよびオプション製品は、クラス A 情報技術装置です。これらの製品には、下記の項目が該当します。

この装置は、情報処理装置等電波障害自主規制協議会 (VCCI) の基準に基づくクラス A 情報技術装置です。この装置を家庭環境で使用すると電波妨害を引き起こすことがあります。この場合には使用者が適切な対策を講ずるよう要求されることがあります。

クラス B VCCI 基準について

クラス B VCCI の表示  があるワークステーションおよびオプション製品は、クラス B 情報技術装置です。これらの製品には、下記の項目が該当します。

この装置は、情報処理装置等電波障害自主規制協議会 (VCCI) の基準に基づくクラス B 情報技術装置です。この装置は、家庭環境で使用することを目的としていますが、この装置がラジオやテレビジョン受信機に近接して使用されると、受信障害を引き起こすことがあります。取扱説明書に従って正しい取り扱いをしてください。

BSMI Class A Notice

The following statement is applicable to products shipped to Taiwan and marked as Class A on the product compliance label.

警告使用者：
這是甲類的資訊產品，在居住的環境中使用時，可能會造成射頻干擾，在這種情況下，使用者會被要求採取某些適當的對策。

Declaration of Conformity

Compliance Model Number: **SUNIFB3**
Product Family Name: **Sun XVR-1200 Graphics Accelerator (X3689A, X3689A-F)**

EMC

USA—FCC Class B

This equipment complies with Part 15 of the FCC Rules. Operation is subject to the following two conditions:

1. This equipment may not cause harmful interference.
2. This equipment must accept any interference that may cause undesired operation.

European Union

This equipment complies with the following requirements of the EMC Directive 89/336/EEC:

As Telecommunication Network Equipment (TNE) in both Telecom Centers and Other Than Telecom Centers per (as applicable): EN300-386 V.1.3.1 (09-2001) Required Limits:

EN55022/CISPR22	Class B
EN61000-3-2	Pass
EN61000-3-3	Pass
EN61000-4-2	6 kV (Direct), 8 kV (Air)
EN61000-4-3	3 V/m 80-1000MHz, 10 V/m 800-960 MHz and 1400-2000 MHz
EN61000-4-4	1 kV AC and DC Power Lines, 0.5 kV Signal Lines
EN61000-4-5	2 kV AC Line-Gnd, 1 kV AC Line-Line and Outdoor Signal Lines, 0.5 kV Indoor Signal Lines > 10m
EN61000-4-6	3 V
EN61000-4-11	Pass

As information Technology Equipment (ITE) Class B per (as applicable):

EN55022:1998/CISPR22:1997	Class B
EN55024:1998	Required Limits:
EN61000-4-2	4 kV (Direct), 8kV (Air)
EN61000-4-3	3 V/m
EN61000-4-4	1 kV AC Power Lines, 0.5 kV Signal and DC Power Lines
EN61000-4-5	1 kV AC Line-Line and Outdoor Signal Lines, 2 kV AC Line-Gnd, 0.5 kV DC Power Lines
EN61000-4-6	3 V
EN61000-4-8	1 A/m
EN61000-4-11	Pass
EN61000-3-2:1995 + A1, A2, A14	Pass
EN61000-3-3:1995	Pass

Safety

This equipment complies with the following requirements of the Low Voltage Directive 73/23/EEC:

EC Type Examination Certificates:

EN60950:2000, 3rd Edition	TÜV Rheinland Certificate No.
IEC 60950:1999, 3rd Edition	CB Scheme Certificate No. US/6562/UL
Evaluated to all CB Countries	
UL 60950, 3rd Edition, CSA C22.2 No. 60950*	File: E138989-A5-UL-1 Vol. X2

Supplementary Information

This product was tested and complies with all the requirements for the CE Mark.

<u>/S/</u>	<u>DATE</u>	<u>/S/</u>	<u>DATE</u>
Dennis P. Symanski Manager, Compliance Engineering Sun Microsystems, Inc. 4150 Network Circle, MPK15-102 Santa Clara, CA 95054 U.S.A. Tel: 650-786-3255 Fax: 650-786-3723		Donald Cameron Program Manager Sun Microsystems Scotland, Limited Blackness Road, Phase I, Main Bldg Springfield, EH49 7LR Scotland, United Kingdom Tel: +44 1 506 672 539 Fax: +44 1 506 670 011	

Contents

Preface	xvii
1. Sun XVR-1200 Graphics Accelerator Overview	1
Installation Kit	1
Sun XVR-1200 Graphics Accelerator Overview	2
Features	3
Additional Features	4
Video Formats	5
Installation Process	6
Technical Support	7
Accessing Field Replaceable Unit Information	7
2. Installing the Sun XVR-1200 Graphics Accelerator Software	9
Software Requirements	9
Sun XVR-1200 Graphics Accelerator Software	10
Software Package Locations	10
Software Packages	11
Solaris Operating System Software Patches	11
Sun OpenGL for Solaris Software	12
Software Package Locations	12

Software Packages	12
Sun OpenGL for Solaris Software Patches	14
Installing the Software	15
Removing the Software	17
Man Pages	18
3. Installing the Sun XVR-1200 Graphics Accelerator Hardware	21
Before Installation	21
System Configurations	22
Installing the Hardware	22
Installing the Hardware in a Sun Blade 2000 System	23
Installing the Hardware in a Sun Fire 6800/6900 System	24
Monitor Cables	26
Changing the Monitor Screen Resolution	27
4. Configuring Multiple Frame Buffers	29
Configuring Multiple Frame Buffers Through the Xservers File	29
Xinerama	31
Using Xinerama	31
Restrictions When Using Xinerama	32
5. Using Sun XVR-1200 Graphics Accelerator Features	33
Streaming Methods	33
Setting Up Streaming Methods	34
Setting Up Single Video Output (Default)	34
Setting Up Two Video Streams Over One Large Frame Buffer	35
Setting Up Two Independent Video Streams	36
Dynamic Multisample Antialiasing	37
Enabling Multisampling for All Sun OpenGL for Solaris Applications	37
Default Color Depth	39

Disabling Multisampling	39
Checking Device Configuration	40
6. Framelocking Sun XVR-1200 Graphics Accelerators	43
Sun XVR-1200 Graphics Accelerator Framelock System	43
Connecting the DB9 Port Framelock Cable	45
Stereo DIN7 Port Framelock Cable	47
Connecting the Stereo Port Framelock Cable	48
Configuring Graphics Accelerators for Framelocking	50
A. Setting the Default Console Display	53
B. Sun XVR-1200 Graphics Accelerator Specifications	57
I/O Port Specifications	57
DVI Video Connector	58
DB9 Video Connector	60
Stereo Connector	62
External Video Synchronization BNC Connector	63
C. Sun XVR-1200 Graphics Accelerator Graphics Library Extensions	65
Sun OpenGL 1.3 for Solaris Extensions	65
Sun OpenGL 1.2.3 for Solaris Extensions	66
Index	67

Figures

FIGURE 1-1	Sun XVR-1200 Graphics Accelerator	2
FIGURE 1-2	Sun XVR-1200 Graphics Accelerator Backplate I/O Ports	3
FIGURE 3-1	Installing Sun XVR-1200 Graphics Accelerator in a Sun Blade 2000 System	23
FIGURE 3-2	Installing Sun XVR-1200 Graphics Accelerator in the I/O Assembly	25
FIGURE 6-1	Sun XVR-1200 Graphics Accelerator DB9/Framelock Connector	45
FIGURE 6-2	Framelock Cabling Through the DB9 Connector	46
FIGURE 6-3	Stereo DIN7 Port Framelock Cable	47
FIGURE 6-4	Sun XVR-1200 Graphics Accelerator Stereo/Framelock Connector	48
FIGURE 6-5	Framelock Cabling Through the Stereo DIN7 Port	49
FIGURE B-1	Sun XVR-1200 Graphics Accelerator I/O Connectors	57
FIGURE B-2	Sun XVR-1200 Graphics Accelerator DVI Connector	58
FIGURE B-3	Sun XVR-1200 Graphics Accelerator DB9 Connector	60
FIGURE B-4	Sun XVR-1200 Graphics Accelerator 7-Pin DIN Female Stereo Connector	62

Tables

TABLE 1-1	Sun XVR-1200 Graphics Accelerator Screen Resolutions	5
TABLE 2-1	Sun XVR-1200 Graphics Accelerator CD-ROM Directories	10
TABLE 2-2	Location of Sun XVR-1200 Graphics Accelerator Software Packages	10
TABLE 2-3	Sun XVR-1200 Graphics Accelerator Software Packages	11
TABLE 2-4	Patches for the Solaris Operating System	11
TABLE 2-5	Location of Sun OpenGL for Solaris Software Packages	12
TABLE 2-6	Sun OpenGL Version 1.3 Packages	12
TABLE 2-7	Sun OpenGL Version 1.2.3 Packages	13
TABLE 2-8	Patches for Sun OpenGL 1.3 for Solaris	14
TABLE 2-9	Patches for Sun OpenGL 1.2.3 for Solaris	14
TABLE 3-1	Supported Systems and Maximum Number of Sun XVR-1200 Graphics Accelerators Per System	22
TABLE 5-1	Multisample Options	38
TABLE 6-1	Stereo DIN7 Port Framelock Cable Connections	47
TABLE B-1	Sun XVR-1200 Graphics Accelerator DVI Video Output Connector	58
TABLE B-2	Sun XVR-1200 Graphics Accelerator DB9 Connector-Multiview In	60
TABLE B-3	Sun XVR-1200 Graphics Accelerator DB9 Connector-Multiview Out	61
TABLE B-4	Sun XVR-1200 Graphics Accelerator Stereo DIN7 Connector Pinout	62

Preface

This guide describes how to install the Sun™ XVR-1200 graphics accelerator in your Sun computer system.

How This Book Is Organized

Chapter 1 provides an overview of the Sun XVR-1200 graphics accelerator product and includes features and supported screen resolutions.

Chapter 2 describes how to install the Sun XVR-1200 graphics accelerator software.

Chapter 3 describes how to install the Sun XVR-1200 graphics accelerator hardware in Sun Blade™ 2000 and Sun Fire™ 6800/6900 systems.

Chapter 4 describes how to modify the `Xservers` configuration file for running more than one frame buffer and how to use Xinerama to configure multiple frame buffers.

Chapter 5 provides information on using Sun XVR-1200 graphics accelerator features, including dynamic multisample antialiasing.

Chapter 6 describes framelocking multiple Sun XVR-1200 graphics accelerators.

Appendix A describe how to set the Sun XVR-1200 graphics accelerator as the default monitor console display.

Appendix B provides I/O port specifications for the Sun XVR-600 graphics accelerator.

Appendix C lists the Sun OpenGL for Solaris graphics library extensions for the Sun XVR-1200 graphics accelerator.

Using UNIX Commands

This document might not contain information on basic UNIX® commands and procedures such as shutting down the system, booting the system, and configuring devices. See the following for this information:

- Software documentation that you received with your system
- Solaris™ Operating System documentation, which is at
<http://docs.sun.com>

Typographic Conventions

Typeface or Symbol	Meaning	Examples
AaBbCc123	The names of commands, files, and directories; on-screen computer output	Edit your <code>.login</code> file. Use <code>ls -a</code> to list all files. % You have mail.
AaBbCc123	What you type, when contrasted with on-screen computer output	% su Password:
<i>AaBbCc123</i>	Book titles, new words or terms, words to be emphasized. Replace command-line variables with real names or values.	Read Chapter 6 in the <i>User's Guide</i> . These are called <i>class</i> options. To delete a file, type rm filename .

Shell Prompts

Shell	Prompt
C shell	<i>machine-name%</i>
C shell superuser	<i>machine-name#</i>
Bourne shell and Korn shell	\$
Bourne shell and Korn shell superuser	#

Accessing Sun Documentation

You can view, print, or purchase a broad selection of Sun documentation, including localized versions, at:

<http://www.sun.com/documentation>

Third-Party Web Sites

Sun is not responsible for the availability of third-party web sites mentioned in this document. Sun does not endorse and is not responsible or liable for any content, advertising, products, or other materials that are available on or through such sites or resources. Sun will not be responsible or liable for any actual or alleged damage or loss caused by or in connection with the use of or reliance on any such content, goods, or services that are available on or through such sites or resources.

Contacting Sun Technical Support

If you have technical questions about this product that are not answered in this document, go to:

<http://www.sun.com/service/contacting>

Sun Welcomes Your Comments

Sun is interested in improving its documentation and welcomes your comments and suggestions. You can submit your comments by going to:

<http://www.sun.com/hwdocs/feedback>

Please include the title and part number of your document with your feedback:

Sun XVR-1200 Graphics Accelerator Installation and User's Guide,
part number 816-7386-12

Sun XVR-1200 Graphics Accelerator Overview

This chapter provides an overview of the Sun XVR-1200 graphics accelerator.

- “Installation Kit” on page 1
- “Sun XVR-1200 Graphics Accelerator Overview” on page 2
- “Video Formats” on page 5
- “Installation Process” on page 6
- “Technical Support” on page 7
- “Accessing Field Replaceable Unit Information” on page 7

To find the systems that support the Sun XVR-1200 graphics accelerator, go to:

<http://www.sun.com/desktop/products/graphics/xvr1200/>

Installation Kit

The Sun XVR-1200 graphics accelerator installation kit includes:

- Sun XVR-1200 graphics accelerator
- Sun XVR-1200 graphics accelerator software (CD-ROM)
- Fan card (included in kit for Sun Fire 6800/6900 systems only)
- Antistatic wrist strap
- *Sun XVR-1200 Graphics Accelerator Installation Guide*, this document

See Chapter 6 to order framelock cables, if required.

Sun XVR-1200 Graphics Accelerator Overview

The Sun XVR-1200 graphics accelerator is a PCI-based graphics accelerator which provides high resolution and high performance PCI 3D graphics. Features include texture memory, PCI 66/33 MHz 64-bit interface, and dual DVI-I video output. The Sun XVR-1200 graphics accelerator occupies two slots.

FIGURE 1-1 shows the Sun XVR-1200 graphics accelerator.

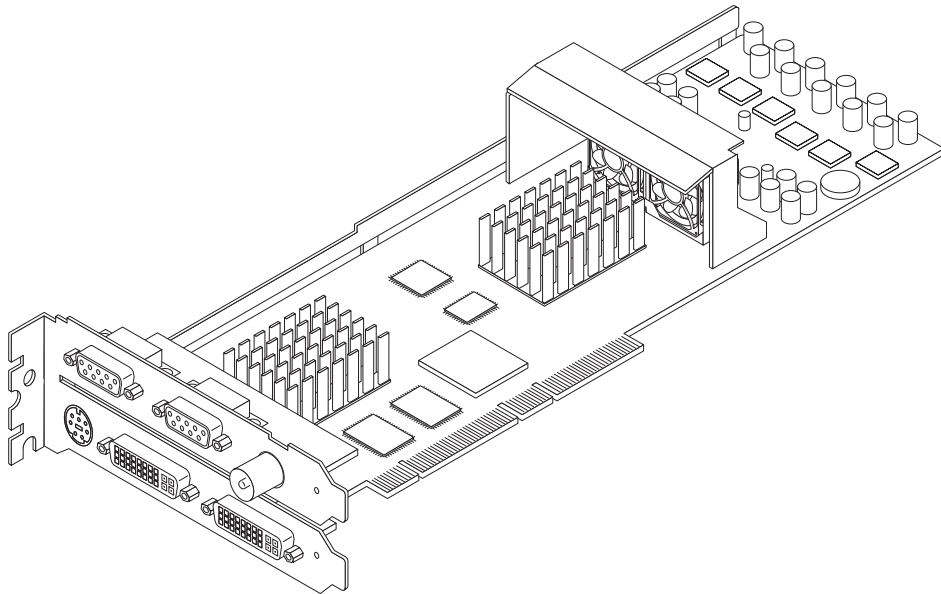

FIGURE 1-1 Sun XVR-1200 Graphics Accelerator

FIGURE 1-2 shows the Sun XVR-1200 graphics accelerator I/O backplate.

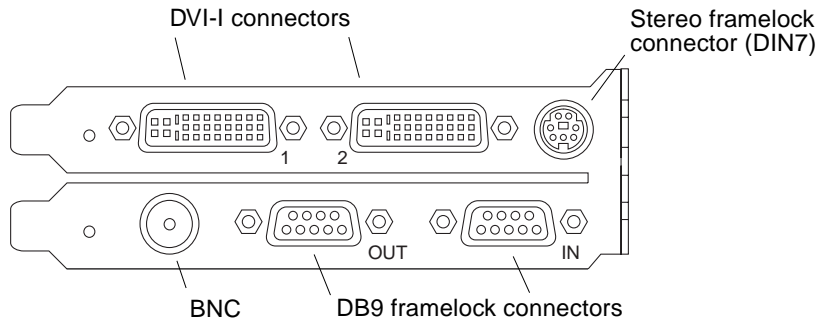

FIGURE 1-2 Sun XVR-1200 Graphics Accelerator Backplate I/O Ports

Note – Only the DVI-1 connector labeled “1” can be used as the console output.

Features

- 32 Mbytes of SDRAM display list memory
- 256 Mbytes of texture memory
- 128 Mbytes of frame buffer memory
- 10-bit gamma correction
- Resolution up to $2048 \times 1536 \times 40$ at 30-bit color
- Dual 1920×1200 screens support from a single board
- Dual 1280×1024 stereo screen support
- Hardware cursor
- Stereoscopic viewing support (frame sequential)
- Display Data Channel (DDC) monitor support for bidirectional communication
- Display Power Management Signaling (DPMS) to enable monitor’s power-saving mode
- High-speed, full-featured DMA over the PCI bus
- Multiscreen support using multiple cards in a single workstation
- Frame locking of the video timing to an external timing source
- Multiview functionality for framelocking of multiple cards
- Two video lookup tables
- Stereo output
- PCI 66/33 MHz 64-bit interface
- Dual DVI-I video out

Additional Features

- Geometry acceleration
 - Model view matrix transformation of vertex and normal coordinates
 - Texture matrix transformation of texture coordinates
 - Full lighting calculations with up to 32 light sources
 - Up to six user clip planes
 - Perspective transformation
 - Viewport transformation
 - View volume clipping
- OpenGL operations (supports Sun OpenGL 1.3 for Solaris)
 - Multi-texture and cube-mapping
 - Points (2D, 3D, wide)
 - Vectors (2D and 3D lines and line strips; wide, stippled)
 - Polygons (triangles, triangle strips, quads, quad strips, polygons, point/line polygon mode)
 - Antialiased points, vectors, and polygons
 - Image support (multiple formats, zoom, bilinear scaling, color matrix, color tables)
 - Alpha operations
 - Scissoring
 - Window clipping
 - Masking
 - Fogging (linear, exponential, exponential², user-defined)
 - Texture mapping (point, bilinear, trilinear, multiple internal formats)
 - Stencil operations
 - Dithering
 - Rich set of blending operations
 - Fast window clears
 - Fast window-mode double buffering
 - Frame-sequential stereo support
- Extensive support of OpenGL
 - Imaging extensions such as pixel buffer, color table, and color matrix
 - Blend extensions such as blend color, blend minmax, and blend function separate
 - Texture extensions (edge clamp, border clamp, LOD clamp, generate mipmap)
 - Texture color table
 - Post-texturing specular
 - Stencil operation wrap

Video Formats

TABLE 1-1 lists the supported screen resolutions for the Sun XVR-1200 graphics accelerator.

- To get a list of all graphics devices on your system, type:

```
host% fbconfig -list
```

- To get a list of available resolutions for your display device, type:

```
host% fbconfig -dev jfb0 -res \?
```

TABLE 1-1 also includes static multisampling sizes for the applicable resolutions for single and dual screens (*spp* is samples per pixel). The heading “Dual Screen” refers to doublewide or doublehigh dual displays.

TABLE 1-1 Sun XVR-1200 Graphics Accelerator Screen Resolutions

Display Resolution	Vertical Refresh Rate	Sync Standard	Aspect Ratio Format	Maximum Number of spp Single Screen	Maximum Number of spp Dual Screen
2048 x 1536	40 Hz	Sun	16:10	1	1
1920 x 1200	60, 70, 75 Hz	Sun	16:10	1	1
1920 x 1200	60_240T Hz	Sun	16:10	1	1
1920 x 1080	72 Hz	Sun	16:9	2	1
1792 x 1344	75 Hz	VESA	4:3	1	1
1600 x 1280	76 Hz	Sun	5:4	1	1
1600 x 1200	60, 75 Hz	VESA	4:3	2	1
1600 x 1000	66, 76 Hz	Sun	16:10	2	1
1440 x 900	76 Hz	Sun	16:10	1	1
1280 x 1024	60, 75, 85 Hz	VESA	5:4	4	1
1280 x 1024	67, 76 Hz	Sun	5:4	4	1
1280 x 1024	112 Hz	Sun-stereo	5:4	2	1
1280 x 800	112 Hz	Sun-stereo	16:10	2	1
1280 x 800	76 Hz	Sun	16:10	4	1

TABLE 1-1 Sun XVR-1200 Graphics Accelerator Screen Resolutions (*Continued*)

Display Resolution	Vertical Refresh Rate	Sync Standard	Aspect Ratio Format	Maximum Number of spp Single Screen	Maximum Number of spp Dual Screen
1152 x 900	66, 76 Hz	Sun	5:4	4	2
1152 x 900	120 Hz	Sun-stereo	5:4	2	1
1024 x 800	84 Hz	Sun	5:4	4	2
1024 x 768	75 Hz	VESA	4:3	4	2
1024 x 768	60, 70, 77 Hz	Sun	4:3	4	2
960 x 680	108, 112 Hz	Sun-stereo	Sun-Stereo	4	2
800 x 600	75	VESA	4:3	8	4
640 x 480	60 Hz	VESA	4:3	16	8

Note – Not all resolutions are supported by all monitors. Using resolutions that are not supported by the monitor may damage the monitor. Refer to your monitor manual for supported resolutions.

Video Display Ports

The Sun XVR-1200 graphics accelerator provides two DVI video output ports. Each DVI video port supports both analog (DVI-A) and digital (DVI-D) video formats. Although the DVI port supports both analog and digital video formats, they cannot be used simultaneously from the individual DVI port.

Installation Process



Caution – The Sun XVR-1200 graphics accelerator is *not* hot-swappable.

1. Install the Sun XVR-1200 graphics accelerator software (Chapter 2).
2. Shutdown the system.
3. Install the Sun 1200 graphics accelerator hardware (Chapter 3), repower the system, and reboot (`boot -r`) for reconfiguration.
4. Modify the `Xservers` configuration file, if needed (Chapter 4).

Technical Support

For assistance and other information not found in this document concerning the Sun XVR-1200 graphics accelerator, see Support Services at:

<http://www.sun.com/service/online/>

For the most up-to-date version of the installation guide, go to:

<http://www.sun.com/documentation>

Accessing Field Replaceable Unit Information

You can obtain Sun XVR-1200 graphics accelerator subcomponent version numbers and other data using `fbconfig`.

- **To obtain FRU ID (field replaceable unit identifier) information, type:**

```
host% fbconfig -dev jfb0 -prconf
--- Hardware Configuration for /dev/fbs/jfb0 ---
Type: XVR-1200
Sun Serial Number: 3753101012803
Hardware Revision: -02 rev50
Manufacture Date: Tue Jan 28 13:15:52 2003
PROM Information: @(#)jfb.fth 1.8 02/10/18 SMI
Monitor/Resolution Information:
    EDID Data: Available - EDID version 1 revision 3
    Monitor type: Sun P/N 365-16981 S/N 02190012336
    Current resolution setting: 1920x1200x60
    Monitor possible resolutions: 1024x768x60, 1024x768x70, 1024x768x75,
    1152x900x66, 1280x1024x60, 1280x1024x75, 1280x1024x76, 640x480x60,
    1920x1200x60, 1920x1200x60_240T, 1600x1200x60, 800x600x75,
    1920x1080x60
Framelock Configuration:
    Slave Mode: Disabled
Memory Information:
    Total Video Memory: 134217728
    Video Memory Used: 18677760
    Total Texture Memory: 268435456
    Texture Memory Used: 0
    Total Display List Memory: 33554432
```

Installing the Sun XVR-1200 Graphics Accelerator Software

This chapter provides Sun XVR-1200 graphics accelerator software installation information.

- “Software Requirements” on page 9
- “Sun XVR-1200 Graphics Accelerator Software” on page 10
- “Sun OpenGL for Solaris Software” on page 12
- “Installing the Software” on page 15
- “Removing the Software” on page 17
- “Man Pages” on page 18

Software Requirements

The Solaris 8 10/01 and Solaris 9 Operating Systems, or a subsequent compatible version of the Solaris Operating System, is required on your system before installing the Sun XVR-1200 graphics accelerator software:

- 1.5 Mbytes of available disk space for Sun XVR-1200 graphics accelerator Solaris system software
- 65-110 Mbytes of disk space for Sun OpenGL[®] for Solaris (up to 110 Mbytes if 64-bit Sun OpenGL for Solaris is installed)

Note – If your system does not have the Solaris 8 10/01 Operating System installed, you must install it. Refer to the main Solaris installation manuals for this information.

Updated versions of Sun OpenGL for Solaris are available at:

<http://www.sun.com/software/graphics/OpenGL/>

Sun XVR-1200 Graphics Accelerator Software

Install the required software packages for your Solaris Operating System from the CD-ROM provided with your Sun XVR-1200 graphics accelerator installation kit. TABLE 2-1 lists the Sun XVR-1200 graphics accelerator CD directories:

TABLE 2-1 Sun XVR-1200 Graphics Accelerator CD-ROM Directories

Directory Name	Description
License	Binary Code License
XVR-1200/Solaris_8/Packages/	Solaris 8 graphics accelerator software packages
XVR-1200/Solaris_9/Packages/	Solaris 9 graphics accelerator software packages
XVR-1200/Solaris_8/Patches/	Solaris 8 graphics accelerator software patches
XVR-1200/Solaris_9/Patches/	Solaris 9 graphics accelerator software patches
Docs/	Sun XVR-1200 graphics accelerator documentation
Copyright	English version of copyright
FR_Copyright	French version of copyright
install	Product installation script
remove	Product removal script
OpenGL/(1.2.3 and 1.3)/Packages/	OpenGL packages

Software Package Locations

The Sun XVR-1200 graphics accelerator software packages are located in the directories listed in TABLE 2-2. If the CD is not already mounted, /cdrom/XVR-1200/ is the path.

TABLE 2-2 Location of Sun XVR-1200 Graphics Accelerator Software Packages

Software Packages	Directory Location
Solaris 8 software	/cdrom/cdrom0/XVR-1200/Solaris_8/Packages
Solaris 9 software	/cdrom/cdrom0/XVR-1200/Solaris_9/Packages

Software Packages

TABLE 2-3 lists the Sun XVR-1200 graphics accelerator software package names and descriptions.

TABLE 2-3 Sun XVR-1200 Graphics Accelerator Software Packages

Package Name	Description
SUNWjfbcf	Sun XVR-1200 Graphics Configuration Software
SUNWjfbmn	Sun XVR-1200 Graphics Manual Page
SUNWjibr	Sun XVR-1200 Graphics System Software (Root)
SUNWjibw	Sun XVR-1200 Graphics Window System Support
SUNWjibx	Sun XVR-1200 Graphics System Software/Device Driver

Solaris Operating System Software Patches

TABLE 2-4 lists the patches required for the applicable Solaris Operating System.

TABLE 2-4 Patches for the Solaris Operating System

Patch	Location
114554-16	/cdrom/cdrom0/XVR-1200/Solaris_8/Patches
114555-16	/cdrom/cdrom0/XVR-1200/Solaris_9/Patches

Sun OpenGL for Solaris Software

The Sun XVR-1200 graphics accelerator is supported in Sun OpenGL Versions 1.2.3 and 1.3 and subsequent compatible Sun OpenGL versions, for Solaris Operating Systems.

Software Package Locations

TABLE 2-5 lists the directory locations of the Sun OpenGL for Solaris software packages.

TABLE 2-5 Location of Sun OpenGL for Solaris Software Packages

Sun OpenGL for Solaris Software Packages	Directory Location
Sun OpenGL 1.2.3 software	/cdrom/cdrom0/OpenGL/1.2.3/Packages/
Sun OpenGL 1.3 software	/cdrom/cdrom0/OpenGL/1.3/Packages/

Updated versions of Sun OpenGL for Solaris are available at:

<http://www.sun.com/software/graphics/OpenGL/>

Software Packages

TABLE 2-6 lists the Sun OpenGL 1.3 for Solaris software package names and descriptions.

TABLE 2-6 Sun OpenGL Version 1.3 Packages

Package Name	Description
SUNWgldoc	Sun OpenGL for Solaris Documentation and Man Pages
SUNWgldp	Sun OpenGL for Solaris Device Pipeline Support
SUNWgldpx	Sun OpenGL for Solaris 64-bit Device Pipeline Support
SUNWglh	Sun OpenGL for Solaris Header Files
SUNWglrt	Sun OpenGL for Solaris Runtime Libraries
SUNWglrtu	Sun OpenGL for Solaris Platform Specific Runtime Libraries
SUNWglrtx	Sun OpenGL for Solaris 64-bit Runtime Libraries

TABLE 2-6 Sun OpenGL Version 1.3 Packages (*Continued*)

Package Name	Description
SUNWgl _{sr}	Sun OpenGL for Solaris Runtime Generic Software
SUNWgl _{sr} _x	Sun OpenGL for Solaris 64-bit Optimized SW Rasterizer
SUNWgl _{sr} _z	Sun OpenGL for Solaris Optimized SW Rasterizer

TABLE 2-7 lists the Sun OpenGL 1.2.3 for Solaris software package names and descriptions.

TABLE 2-7 Sun OpenGL Version 1.2.3 Packages

Package Name	Description
SUNWaf _{bg} _l	Sun OpenGL for Solaris Elite3D support
SUNWaf _{bg} _x	Sun OpenGL for Solaris 64-bit Elite3D support
SUNWff _{bg} _l	Sun OpenGL for Solaris Creator Graphics (FFB) Support
SUNWff _{bg} _x	Sun OpenGL for Solaris 64-bit Creator Graphics (FFB) Support
SUNWgf _{bg} _l	Sun OpenGL for Solaris Gfb Support
SUNWgf _{bg} _x	Sun OpenGL for Solaris 64-bit Gfb Support
SUNWgl _{doc}	Sun OpenGL for Solaris Documentation and Man Pages
SUNWgl _h	Sun OpenGL for Solaris Header Files
SUNWgl _{rt}	Sun OpenGL for Solaris Runtime Libraries
SUNWgl _{rtu}	Sun OpenGL for Solaris Platform Specific Runtime Libraries
SUNWgl _{rtx}	Sun OpenGL for Solaris 64-bit Runtime Libraries
SUNWgl _{sr}	Sun OpenGL for Solaris Runtime Generic Software
SUNWgl _{sr} _x	Sun OpenGL for Solaris 64-bit Optimized SW Rasterizer
SUNWgl _{sr} _z	Sun OpenGL for Solaris Optimized SW Rasterizer
SUNWif _{bg} _l	Sun OpenGL for Solaris Expert3D/Expert3D-Lite/XVR-500 Graphics Support
SUNWif _{bg} _x	Sun OpenGL for Solaris 64-bit Expert3D/Expert3D-Lite/XVR-500 Graphics Support
SUNWjf _{bg} _l	Sun OpenGL for Solaris XVR-1200 Graphics Support
SUNWjf _{bg} _x	Sun OpenGL for Solaris 64-bit XVR-1200 Graphics Support

Sun OpenGL for Solaris Software Patches

TABLE 2-9 lists the patches required for Sun OpenGL 1.3 for Solaris.

TABLE 2-8 Patches for Sun OpenGL 1.3 for Solaris

Patch	Location
113886-21 (32-bit) or later	/cdrom/cdrom0/OpenGL/1.3/Patches
113887-21 (64-bit) or later	/cdrom/cdrom0/OpenGL/1.3/Patches

TABLE 2-9 lists the patches required for Sun OpenGL 1.2.3 for Solaris.

TABLE 2-9 Patches for Sun OpenGL 1.2.3 for Solaris

Patch	Location
112628-27 (32-bit) or later	/cdrom/cdrom0/OpenGL/1.2.3/Patches
112629-27 (64-bit) or later	/cdrom/cdrom0/OpenGL/1.2.3/Patches

Note – If your currently installed version of Sun OpenGL for Solaris does *not* include the -27 patch level, the Sun XVR-1200 graphics accelerator software installation script upgrades to the proper -27 patch level.

Note – Always check for the latest software patches at:
<http://sunsolve.sun.com/>

Installing the Software

Use the `install` utility on the CD-ROM to install the Sun XVR-1200 graphics accelerator software. This utility installs necessary driver software and patches.

1. **Log in as superuser.**
2. **Insert the Sun XVR-1200 graphics accelerator CD into the drive.**
 - If the drive is already mounted, type the following, and go to Step 3:

```
# cd /cdrom/cdrom0
```

- If the CD is not already mounted, type:

```
# mount -F hsfs -O -o ro /dev/dsk/c0t6d0s0 /cdrom
# cd /cdrom
```

Note – The CD-ROM device might be different on your system. For example, `/dev/dsk/c0t2d0s2`.

3. **To install the Sun XVR-1200 graphics accelerator software, type:**

```
# ./install
```

The following is displayed:

```
*** Checking if Sun XVR-1200 Graphics Accelerator support is already
    installed...
*** Checking for required OS patch(es) ...
*** Checking if Sun OpenGL is installed...

Select one of the following Sun OpenGL installation options:
1) Install Sun OpenGL 1.3
2) Install Sun OpenGL 1.2.3
3) Do not install Sun OpenGL
Select an option:
```

The installation program checks if Sun XVR-1200 graphics accelerator software is already installed. If already installed, the following is displayed:

```
All required software for the Sun XVR-1200 Graphics Accelerator and
Sun OpenGL support is already installed. No software will be
installed at this time.
```

4. Select the Sun OpenGL for Solaris version and press Return.

The following is displayed. (Option 1, Sun OpenGL 1.3 for Solaris, is selected for this example on a Solaris 8 Operating System.)

```
*** Checking for required Sun OpenGL patch(es) ...

About to take the following actions:
- Install Sun XVR-1200 Graphics Accelerator support for Solaris 8
- Install Sun OpenGL 1.3

To cancel installation of this software, press 'q'.
Press any other key to begin installation:
```

5. Press Return to begin installation.

When complete, the following is displayed:

Note – Depending on your system configuration, the actual output from the installation process may differ from what is shown below.

```
*** Installing Sun XVR-1200 Graphics Accelerator support for Solaris 8...
*** Installing Sun OpenGL 1.3...
*** Installation complete.
```

6. Shut down the system after the Sun XVR-1200 graphics accelerator software is installed:

```
# shutdown
```

See the `shutdown(1M)` and `boot(1M)` man pages for more details.

7. Go to Chapter 3 for information on installing the Sun XVR-1200 graphics accelerator hardware.

8. Boot your system at the ok prompt:

Halt (Stop-A) your system for the ok prompt.

```
ok boot -r
```

Note – After you complete the basic installation and configuration of your system, you can use the Sun Install Check Tool to check proper patches, software levels, and so on. Download tool at:

<http://www.sun.com/software/installcheck/index.html>

Removing the Software

1. Log in as superuser.

2. Insert the Sun XVR-1200 graphics accelerator CD into the drive.

- If the drive is already mounted, type the following, and go to Step 4:

```
# cd /cdrom/cdrom0
```

- If the CD is not already mounted, type:

```
# mount -F hsfs -O -o ro /dev/dsk/c0t6d0s0 /cdrom
# cd /cdrom
```

3. To remove the Sun XVR-1200 graphics accelerator software, become superuser and type:

```
# ./remove
```

The following list of options is displayed:

```
1) Remove Sun XVR-1200 Graphics Accelerator support
2) Remove Sun OpenGL
3) Remove All (Sun XVR-1200 Graphics Accelerator and Sun OpenGL)
4) Quit
Select an option:
```

4. Select Option 3 to remove all listed software packages.

The following text is displayed:

```
About to take the following actions:  
- Remove Sun XVR-1200 Graphics Accelerator support  
- Remove Sun OpenGL  
Press 'q' to quit, or press any other key to continue:
```

5. Press Return to start the removal process.

Once complete, the following is displayed and the program provides the location of a removal log:

```
*** Removing packages...  
*** Done. A log of this removal can be found at:  
    /var/tmp/jfb.remove.2002.08.22
```

Man Pages

The Sun XVR-1200 graphics accelerator man pages describe how you can query and set frame buffer attributes such as screen resolutions and visual configurations.

Use the `fbconfig(1M)` man page for configuring all Sun graphics accelerators. `SUNWjfb_config(1M)` contains Sun XVR-1200 device-specific configuration information. To get a list of all graphics devices on your system, type:

```
host% fbconfig -list
```

Use the `fbconfig -help` option to display the attributes and parameters information of the man page.

```
host% fbconfig -dev jfb0 -help
```

- To access the `fbconfig` man page, type:

```
host% man fbconfig
```

- To access the Sun XVR-1200 graphics accelerator man page, type:

```
host% man SUNWjfb_config
```

Installing the Sun XVR-1200 Graphics Accelerator Hardware

This chapter provides Sun XVR-1200 graphics accelerator hardware installation information.

- "Before Installation" on page 21
- "System Configurations" on page 22
- "Installing the Hardware" on page 22
- "Installing the Hardware in a Sun Blade 2000 System" on page 23
- "Installing the Hardware in a Sun Fire 6800/6900 System" on page 24
- "Monitor Cables" on page 26
- "Changing the Monitor Screen Resolution" on page 27

Before Installation

Refer to your system platform documentation for proper procedures on how to shut down the system safely before installing or removing any internal boards and how to reboot the system after installation. Access documentation at:

<http://www.sun.com/documentation>

System Configurations

To find the most recent information on supported systems for the Sun XVR-1200 graphics accelerator, and additional specifications, go to:

<http://www.sun.com/desktop/products/graphics/xvr1200/>

Note – The Sun XVR-1200 graphics accelerator consumes 50 watts of system power.

TABLE 3-1 lists the maximum number of Sun XVR-1200 graphics accelerators for each Sun system supported.

TABLE 3-1 Supported Systems and Maximum Number of Sun XVR-1200 Graphics Accelerators Per System

System	Maximum Number of Sun XVR-1200 Graphics Accelerators
Sun Blade 2000 system	2
Sun Blade 2500 system	2
Sun Fire V440 system	2
Sun Fire 6800/6900 system	4

Installing the Hardware

Refer to the platform documentation provided with your supported Sun system (TABLE 3-1) for detailed instructions on installing Sun PCI bus graphics boards.

This document includes procedures for the Sun Blade 2000 and Sun Fire 6800/6900 systems, however, refer to the following documentation provided with your Sun system for detailed instructions:

- *Sun Blade 1000 and Sun Blade 2000 Service Manual* (816-3217)
Note that only the Sun Blade 2000 system supports the Sun XVR-1200 graphics accelerator.
- *Sun Fire 6800/6900/4810/4800/3800 Systems Service Manual* (805-7363)
Note that only the Sun Fire 6800/6900 system supports the Sun XVR-1200 graphics accelerator.

Access this documentation at: <http://www.sun.com/documentation>

Installing the Hardware in a Sun Blade 2000 System

On Sun Blade 2000 systems, you can *only* install the Sun XVR-1200 graphics accelerator in a 33 Mhz slot (the board occupies two slots). Do *not* use the 66 Mhz slot; its location prohibits the use of a double wide graphics board.



Caution – The Sun XVR-1200 graphics accelerator is *not* hot-swappable.

1. Shut down your system. attach the antistatic wrist strap.
2. Remove the Sun Blade 2000 access panel and lay the system on its side.
3. Attach the antistatic wrist strap and connect the ESD strap to the system.
4. Position the Sun XVR-1200 graphics accelerator in the chassis (FIGURE 3-1).
5. Guide the graphics board bracket tab into the chassis backpanel opening.

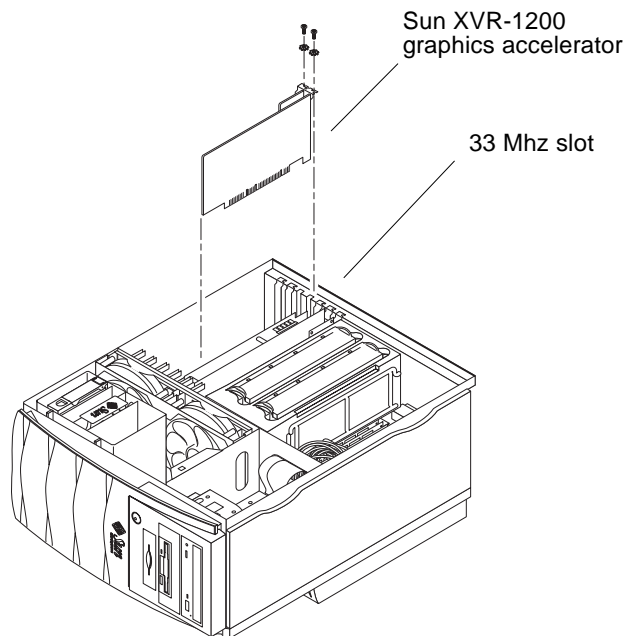

FIGURE 3-1 Installing Sun XVR-1200 Graphics Accelerator in a Sun Blade 2000 System

6. Holding the two upper corners of the graphics board, push the board straight down into the connector until the board is fully seated.
7. Replace the Phillips screw securing the bracket tab to the system chassis.
8. Replace the side access cover.
9. Connect the monitor cable, power on the system and reboot (`boot -r`) for reconfiguration.
10. For multiple graphics boards, modify the `/etc/dt/config/Xservers` file.

This file tells your system to run the X window system on each of the frame buffers listed in your `Xservers` file. If you remove graphics boards from your system, you also need to modify your `Xservers` file. See Chapter 4, “Configuring Multiple Frame Buffers.”

Installing the Hardware in a Sun Fire 6800/6900 System

On Sun Fire 6800/6900 systems, you can *only* install the Sun XVR-1200 graphics accelerator in slot 7 (slot 6 must be empty since the board occupies two slots). The Sun XVR-1200 graphics accelerator requires a fan card, provided in the installation kit, in the adjacent slot (slot 5).



Caution – The Sun XVR-1200 graphics accelerator is *not* hot-swappable.

1. **Shut down your system and remove the Sun Fire 6800/6900 PCI I/O assembly.**

Refer to the *Sun Fire 6800/6900/4810/4800/3800 Systems Service Manual* for details on removing and replacing PCI I/O assemblies.

 - a. **Loosen the four I/O assembly captive phillips screws and pull the ejector levers outward (FIGURE 3-2).**
 - b. **Slide out the I/O assembly and place it on an ESD mat close to the system.**
2. **Attach the antistatic wrist strap and connect the ESD strap to the system.**
3. **Lay the I/O assembly on its side (FIGURE 3-2).**
4. **Position the Sun XVR-1200 graphics accelerator in the I/O assembly (FIGURE 3-2).**

5. Guide the graphics board into I/O assembly slot 7 (FIGURE 3-2).
 - a. Insert the faceplate end of the graphics board into the appropriate opening in the I/O assembly back panel.
 - b. Guide the opposite end of the graphics board into the card slot.
 - c. Secure the faceplate to the I/O assembly with the two Phillips screws.
6. Position the fan card in the I/O assembly (FIGURE 3-2).
7. Guide the fan card into I/O assembly slot 5 (FIGURE 3-2).
 - a. Insert the faceplate end of the fan card into the appropriate opening in the I/O assembly back panel.
 - b. Guide the opposite end of the fan card into the card slot.
 - c. Secure the faceplate to the I/O assembly.

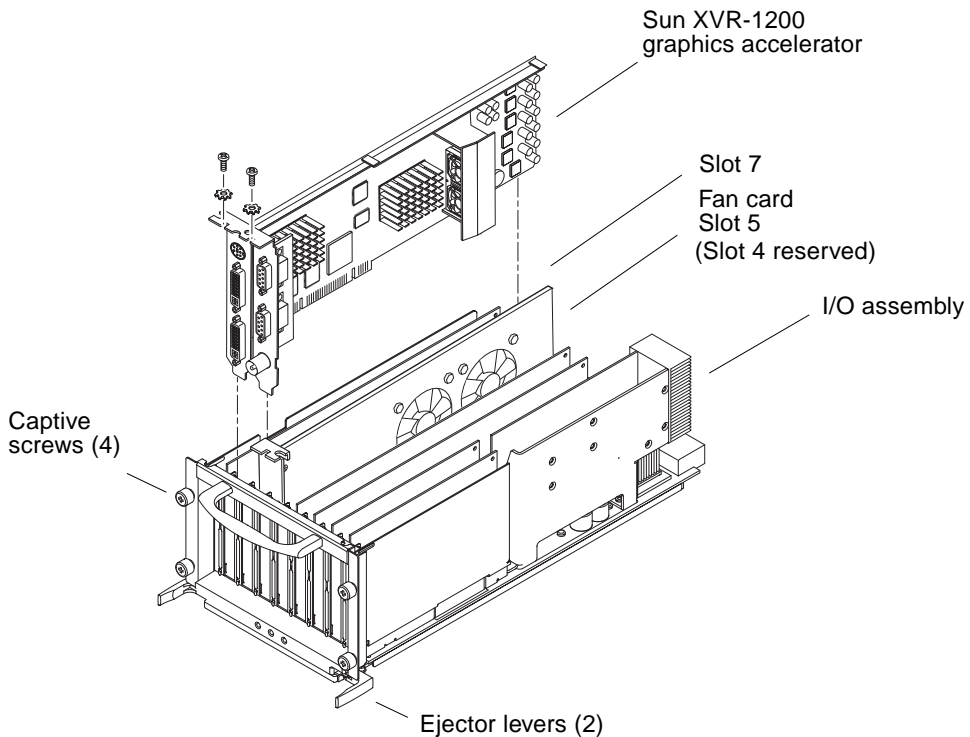

FIGURE 3-2 Installing Sun XVR-1200 Graphics Accelerator in the I/O Assembly

8. Insert and secure filler boards into any other open slots.

The Sun XVR-1200 graphics accelerator occupies two slots.

9. Replace the I/O assembly into the Sun Fire 6800/6900 chassis.

a. Line up the I/O assembly with the chassis I/O assembly opening and slide it into the chassis.

b. Simultaneously press the two ejector levers inward and tighten the four captive Phillips screws snugly by hand.

10. Connect the monitor cable, power on the system and reboot (`boot -r`) for reconfiguration.

11. For multiple graphics boards, modify the `/etc/dt/config/Xservers` file.

This file tells your system to run the X window system on each of the frame buffers listed in your `Xservers` file. See Chapter 4, “Configuring Multiple Frame Buffers” for specific `Xservers` file instructions for Sun Fire 6800/6900 systems.

Monitor Cables

Use the proper DVI-I monitor adapter cable that supports your monitor. Use a DVI-I to 13W3 cable (Sun part number 530-3170) for monitors that support 13W3 video displays. Use a DVI-I to HD15 cable (Sun part number 530-3171) for monitors that support HD15 video displays. You can order the DVI-I adapter cables through the Sun store (<http://store.sun.com>).

Changing the Monitor Screen Resolution

Note – The monitor *must* be connected to the Sun XVR-1200 graphics accelerator and powered on for it to configure to the initial monitor resolution.

For most installations, the Sun XVR-1200 graphics accelerator device automatically configures itself to the screen resolution and refresh rate for your monitor. If it is not a Sun monitor, however, that is connected to the Sun XVR-1200 graphics accelerator device, the monitor might have the wrong screen resolution. To change the screen resolution, use the `fbconfig` utilities which is used for configuring all Sun graphics accelerators. `SUNWjfb_config(1M)` contains Sun XVR-1200 device-specific configuration information.

- To access the `SUNWjfb_config` man page, type:

```
# man SUNWjfb_config
```

Configuring Multiple Frame Buffers

This chapter describes procedures for setting up multiple frame buffers.

- “Configuring Multiple Frame Buffers Through the Xservers File” on page 29
- “Xinerama” on page 31

Configuring Multiple Frame Buffers Through the Xservers File

To run more than one frame buffer you must modify your `/etc/dt/config/Xservers` file. The Sun XVR-1200 graphics accelerator device name is `jfb` (for example, `jfb0` and `jfb1` for two Sun XVR-1200 graphics accelerator devices). To do this:

1. **Become superuser and open the `/etc/dt/config/Xservers` file.**

```
# cd /etc/dt/config
# vi + Xservers
```

If the `/etc/dt/config/Xservers` file does not exist, create the `/etc/dt/config` directory and copy the `Xservers` file from `/usr/dt/config/Xservers` to `/etc/dt/config`.

```
# mkdir -p /etc/dt/config
# cp /usr/dt/config/Xservers /etc/dt/config
# cd /etc/dt/config
# vi + Xservers
```

2. Modify the file by adding the device locations for the applicable frame buffers being used. See the following examples:

Note – For Sun Fire 6800 systems, use `local_uid@none` instead of `local_uid@console` when configuring the `Xservers` file.

Enter the `Xservers` file content on a single line. See the following examples.

This example shows the `Xservers` configuration file modified for one Sun XVR-500 graphics accelerator and one Sun XVR-1200 graphics accelerator:

```
:0 Local local_uid@console root /usr/openwin/bin/Xsun -dev /dev/fbs/ifb0  
-dev /dev/fbs/jfb0
```

This example shows the `Xservers` configuration file modified for one Sun XVR-1200 graphics accelerator:

```
:0 Local local_uid@console root /usr/openwin/bin/Xsun -dev /dev/fbs/jfb0
```

3. Log out, then log back in.

If you are editing the `Xservers` file after completing all the installation steps outlined in Chapter 1, “Installation Process” on page 6, including the reconfiguration, simply reboot your system.

Xinerama

Refer to the proper `Xservers(1)` man page and Xservers documentation for further information. Xinerama is an X window system feature available in Solaris 8 system software and subsequent compatible releases for Sun graphics boards including the Sun XVR-1200 graphics accelerator.

Using Xinerama

When the window system is started in Xinerama mode, all windows can be seamlessly moved across screen boundaries, thus creating one large, super high-resolution, virtual display. With Sun OpenGL 1.2.3 and 1.3 for Solaris or subsequent compatible releases, this functionality is extended to OpenGL applications. No recompilation is necessary for a legacy application to work with Xinerama mode across multiple screens, even if the application was compiled with an older version of Sun OpenGL for Solaris.

- **To enable Xinerama mode (single logical screen) on multiscreen displays, add `+xinerama` to the `Xsun` command line in the `/etc/dt/config/Xservers` file.**

For example, as superuser, type:

```
# cd /etc/dt/config
# vi + Xservers
:0 Local local_uid@console root /usr/openwin/bin/Xsun +xinerama
-dev /dev/fbs/jfb0 -dev /dev/fbs/jfb1
```

Note – For Sun Fire 6800 systems, use `local_uid@none` instead of `local_uid@console` when configuring the `Xservers` file.

There is some affect to performance when using Xinerama. “Setting Up Two Video Streams Over One Large Frame Buffer” on page 35, in Chapter 5, describes an alternative to Xinerama which in some cases may improve performance.

Restrictions When Using Xinerama

- Sample density is irrelevant to Xinerama. Therefore, screens of different sample density can be combined using Xinerama.
- Both screens must have the same visuals to be combined using Xinerama. In practice, this means they must be the same device (family).
- Both screens that the X window system thinks are side by side must have the same height to be combined using Xinerama.
- Both screens that the X window system thinks are above and below must have the same width to be combined using Xinerama.

Using Sun XVR-1200 Graphics Accelerator Features

This chapter provides Sun XVR-1200 graphics accelerator feature information.

- “Streaming Methods” on page 33
- “Setting Up Streaming Methods” on page 34
- “Dynamic Multisample Antialiasing” on page 37
- “Checking Device Configuration” on page 40

Streaming Methods

There are three methods described in this section for streaming video from which to choose with the Sun XVR-1200 graphics accelerator. This section lists the options:

- Single video output for full performance on a single screen (default)
- Two video streams over one large frame buffer
- Two independent video streams

The following section, “Setting Up Streaming Methods” on page 34, describes how to set up these streaming methods.

Setting Up Streaming Methods

When there are two Sun XVR-1200 graphics accelerators in a system, they are numbered from 0 and by ones (0, 1, 2, 3,)

Setting Up Single Video Output (Default)

This enables the first DVI-I port 1 output only. This is the default the system uses if no `fbconfig` commands have been given, or after `fbconfig -dev jfb0 -defaults`.

To set up single video output, do the following:

1. **If enabled, disable doublewide mode.**

This disables doublewide mode, but maximizes sample density. Use `-defaults` to get the maximum sample size of 16. Type:

```
host% fbconfig -dev jfb0 -defaults
```

2. **Set the desired screen resolution. Type:**

```
host% fbconfig -dev jfb0 -res 1280x1024x76
```

To find all possible Sun XVR-1200 graphics accelerator resolutions, type:

```
host% fbconfig -res \?
```

Setting Up Two Video Streams Over One Large Frame Buffer

This enables two monitor support without the use of Xinerama software. This means that the Sun XVR-1200 graphics accelerator creates one wide (or tall) frame buffer, displayed across two screens.

To set up two video streams over one frame buffer, do the following:

1. Enable both streams, sharing a single frame buffer. Type:

```
host% fbconfig -dev jfb0 -doublewide enable
```

- Use the `-doublehigh` option for displays that are set one above the other (rather than side-by-side as for the `-doublewide` option). Both monitors must have the same resolution (selected in Step 2).
- Use the `-outputs swap` option to reverse the positions of the two outputs relative to each other. The default is `direct`. Both monitors must have the same resolution.
- Use the `-offset` option to adjust the position of the specified stream by the value specified.

```
-offset xval yval
```

This is only implemented in `-doublewide` and `-doublehigh` modes. For `-doublewide`, `xval` is used to position the rightmost stream. Negative is left (overlaps with the left stream). For `-doublehigh`, the `yval` is used to position the bottom stream. Negative is up (overlaps with top stream). The default is `[0, 0]`.

2. Set the desired screen resolution. Type:

```
host% fbconfig -dev jfb0 -res 1280x1024x76
```

Setting Up Two Independent Video Streams

This allows independent resolution and sample density for each stream.

Note – This streaming method is not supported in Xinerama on a single board. X window system and Sun OpenGL for Solaris performance may be noticeably degraded in this mode.

Set up two video streams over one large frame buffer whenever possible for a dual stream configuration. See “Setting Up Two Video Streams Over One Large Frame Buffer” on page 35.

To set up two independent video streams, do the following:

1. **To enable both streams, both devices `/dev/fbs/jfb0a` and `/dev/fbs/jfb0b` must appear in the `/etc/dt/config/Xservers` file.**

As superuser, modify the `Xservers` file. For example:

```
# cd /etc/dt/config
# vi + Xservers
:0 Local local_uid@console root /usr/openwin/bin/Xsun -dev
/dev/fbs/jfb0a -dev /dev/fbs/jfb0b
```

2. **Select an independent screen resolution (and sample density, if desired) for each frame buffer. Type:**

```
host% fbconfig -dev jfb0a -res 1280x1024x76
host% fbconfig -dev jfb0b -res 1152x900x66
```

Dynamic Multisample Antialiasing

Multisampling (full-scene dynamic multisample antialiasing) removes the jagged edges on 3D data. An image is sampled at a higher resolution than the screen, typically four to 16 samples per pixel. This method yields improved images, but at the price of possibly increased render time.

The Sun XVR-1200 graphics accelerator has 128 Mbytes of memory for the frame buffer so that the image can be multisampled at up to 16 samples per pixel in a single pass, depending on the resolution. The higher number of samples per pixel, the better the image quality but the longer the rendering time (and the more memory is consumed). Depending on the screen resolution (TABLE 1-1 on page 5), the number of samples per pixel, or *sample density*, can be increased to improve image quality.

To invoke multisampling, use the `fbconfig` command `-multisample` and `-samples` options. You can enable multisample mode for all Sun OpenGL for Solaris applications.

`fbconfig` controls frame buffer memory consumption (at the time the X window system starts).

Enabling Multisampling for All Sun OpenGL for Solaris Applications

- Use `fbconfig` to enable all Sun OpenGL for Solaris application windows for multisampling.

```
host% fbconfig -dev jfb0 -multisample forceon
```

This enables multisampling for all Sun OpenGL for Solaris applications.

Multisampling

Multisample allocation occurs when the system is started or restarted. The configuration `samples-per-pixel` parameter specifies the depth that is pre-allocated. TABLE 5-1 describes the `fbconfig -multisample` options.

```
-multisample [available | disable | forceon]
```

TABLE 5-1 Multisample Options

Option	Description
<code>available</code>	Multisample is possible but is selected on a per application basis. A fixed numbers of samples is used per pixel.
<code>disable</code>	No multisample is possible. <code>disable</code> is the default.
<code>forceon</code>	Multisampling for all Sun OpenGL for Solaris windows. A fixed number of samples is used per pixel. <code>forceon</code> is the default. (<code>force</code> is an acceptable abbreviation for this option.)

Sample Density

The `-samples` option specifies the number of samples per pixel to allocate when multisample is not set to `disable`. The available `-sample` sizes are 1, 2, 4, 8, or 16.

```
-samples [1 | 2 | 4 | 8 | 16 | adaptive]
```

The maximum sample size is 16 samples per pixel. Using `-samples 16`, the sample size is automatically allocated based on the frame buffer memory and video resources available to the stream as the window system starts up. Though the allowable choices are 1 to 16, a very high sample density can be allocated only at low resolution. See “Disabling Multisampling” on page 39.

The `adaptive` option is the default setting for `-samples`. When you use the `-samples adaptive` option, two samples are preallocated per pixel (extra samples are then assigned to pixels that need it).

See TABLE 1-1 on page 5 for a list of how many samples per pixel are supported at various maximum 3D resolutions. The TABLE 1-1 heading “Dual screen” refers to doublewide or doublehigh displays.

- 3. Log out, then log back in to restart the X window system for the changes to take effect.**

Default Color Depth

Use the `-defdepth` option to set the default depth (bits per pixel) on the device. Possible values are 8 or 24.

```
-defdepth 8 | 24
```

Log out of the current window system session and log back in for the change to take effect. Any depth setting in the `Xserver` command line takes precedence over what is set using `fbconfig`. The default is 8.

Disabling Multisampling

When you disable multisampling, no multisample rendering is possible. Only one sample per pixel is allocated, despite any `-samples` option value.

1. **To disable multisampling, type:**

```
host% fbconfig -dev jfb0 -multisample disable
```

2. **Log out, then log back in.**

Checking Device Configuration

Use `fbconfig` to check the X window system (`-propt`) and Sun XVR-1200 graphics accelerator (`-prconf`) device configuration values.

The `fbconfig -propt` option displays the values of all options (for the specified device) saved in the `OWconfig` file. These are the values the X window system will use the next time it starts on that device:

```
host% fbconfig -dev jfb0 -propt

--- OpenWindows Configuration for /dev/fbs/jfb0 ---

OWconfig: machine
Video Mode: 1920x1200x60
Accum: Enabled (allocate an accumulation buffer if possible)

Multisample Information:
  Multisample Mode: Disabled (multisample visuals will not be available)
  Samples Per Pixel: N/A (multisampling disabled)

Screen Information:
  DoubleWide: Disabled
  DoubleHigh: Disabled
  Output Configuration: Direct
  Offset/Overlap: [0, 0]

Visual Information:
  Default Visual: Non-Linear Normal Visual
  Visual Ordering: Linear Visuals are last
  Gamma Correction Value: 2.22
  Gamma Correction Table: Available
  Fake8 rendering: disabled
  Default Visual Depth (defdepth): 8
```

`fbconfig -prconf` option displays the current Sun XVR-1200 graphics accelerator device configuration. If certain values (for example, resolution and sample density) differ from those displayed in `-propt`, it is because those values have been configured since the X window system started.

```
host% fbconfig -dev jfb0 -prconf

--- Hardware Configuration for /dev/fbs/jfb0 ---

Type: XVR-1200
Sun Serial Number: 3753101012803
Hardware Revision: -02 rev50
Manufacture Date: Tue Jan 28 13:15:52 2003
PROM Information: @(#)jfb.ftb 1.8 02/10/18 SMI

Monitor/Resolution Information:
  EDID Data: Available - EDID version 1 revision 3
  Monitor type: Sun P/N 365-16981 S/N 02190012336
  Current resolution setting: 1920x1200x60
Monitor possible resolutions: 1024x768x60, 1024x768x70, 1024x768x75,
  1152x900x66, 1280x1024x60, 1280x1024x75, 1280x1024x76, 640x480x60,
  1920x1200x60, 1920x1200x60_240T, 1600x1200x60, 800x600x75,
  1920x1080x60

Framelock Configuration:
  Slave Mode: Disabled

Memory Information:
  Total Video Memory: 134217728
  Video Memory Used: 18677760
  Total Texture Memory: 268435456
  Texture Memory Used: 0
  Total Display List Memory: 33554432
```

Framelocking Sun XVR-1200 Graphics Accelerators

This chapter describes framelocking multiple Sun XVR-1200 graphics accelerators.

- “Sun XVR-1200 Graphics Accelerator Framelock System” on page 43
- “Connecting the DB9 Port Framelock Cable” on page 45
- “Stereo DIN7 Port Framelock Cable” on page 47
- “Connecting the Stereo Port Framelock Cable” on page 48
- “Configuring Graphics Accelerators for Framelocking” on page 50

Sun XVR-1200 Graphics Accelerator Framelock System

The framelock synchronization feature enables vertical retracing to occur simultaneously on each Sun XVR-1200 graphics accelerator subsystem. Cabling is required to framelock two or more Sun XVR-1200 graphics accelerator subsystems for multiview. Vertical retrace synchronization eliminates flicker between multiscreen displays. You can framelock two or more Sun XVR-1200 graphics accelerator subsystems across one or more computer systems.

You can framelock two or more Sun XVR-1200 graphics accelerators through either the DB9 ports or the stereo port. The DB9 port requires DB9 framelock cables and the stereo DIN7 port requires a Y-shaped framelock daisy-chain cable with three connectors. When longer cables are required for framelocking, framelock through the stereo port using the Y-shaped daisy-chain cable.

The DB9 ports provide a more accurate way to framelock graphics boards because the pixel clock is transmitted over the DB9 connector so that connected graphics boards stay perfectly synchronized rather than drifting slightly over a frame time.

Framelocking is necessary when running multiple stereo displays for the same observer. All the displays must be synchronized so that the left and right views can be seen correctly through one set of LCD stereo glasses.

Note – The only means of synchronizing multiple stereo displays using stereo glasses and stereo emitters is through the stereo DIN7 connector (see “Connecting the Stereo Port Framelock Cable” on page 48).

When frame buffers are framelocked, you should make sure they are all running at the exact same vertical retrace rate. This is normally achieved by selecting the same video format (resolution and refresh rate) (see `fbconfig -help` for details). See “Configuring Graphics Accelerators for Framelocking” on page 50.

Note – You will need *either* the DB9 framelock cable *or* the framelock stereo synchronization cable to framelock Sun XVR-1200 graphics accelerators. Only one type is required depending on your method of framelocking.

To order the DB9 port framelock cable, call Sun telesales at 1-800-786-0404 and request spare part number 530-3188. You can also order the DB9 cable through the Sun store (<http://store.sun.com>).

To order the stereo framelock daisy-chain cable, call Sun telesales at 1-800-786-0404 and request spare part number 530-2754. You can also order the framelock cable through the Sun store (<http://store.sun.com>) by ordering this part number under spare parts.

By default, video streams from separate Sun XVR-1200 graphics accelerators are *not* framelocked.

Connecting the DB9 Port Framelock Cable

Cable the Sun graphics accelerators before configuring your system for framelock (described in “Configuring Graphics Accelerators for Framelocking” on page 50).

1. Locate the master Sun XVR-1200 graphics accelerator I/O backplate on the rear of your system and its DB9 OUT connector (FIGURE 6-1).

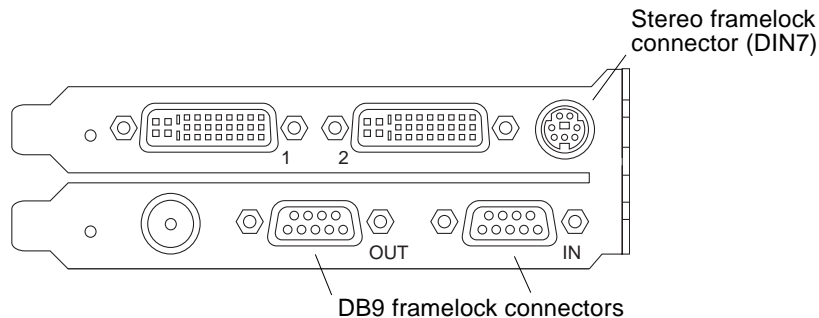

FIGURE 6-1 Sun XVR-1200 Graphics Accelerator DB9/Framelock Connector

2. Connect one end of the DB9 frame lock cable to the master DB9 OUT connector (FIGURE 6-2).

Hand-tighten the DB9 cable connector thumb screws to secure it to the graphics board DB9 connector.

3. Connect the other end of the frame lock cable to a slave Sun XVR-1200 graphics accelerator DB9 IN connector (FIGURE 6-2).

Hand-tighten the DB9 cable connector thumb screws to secure it to the graphics board DB9 connector.

4. For additional slave Sun XVR-1200 graphics accelerators, connect the DB9 cable from the OUT connector of the first slave graphics board to the second slave graphics board (FIGURE 6-2).

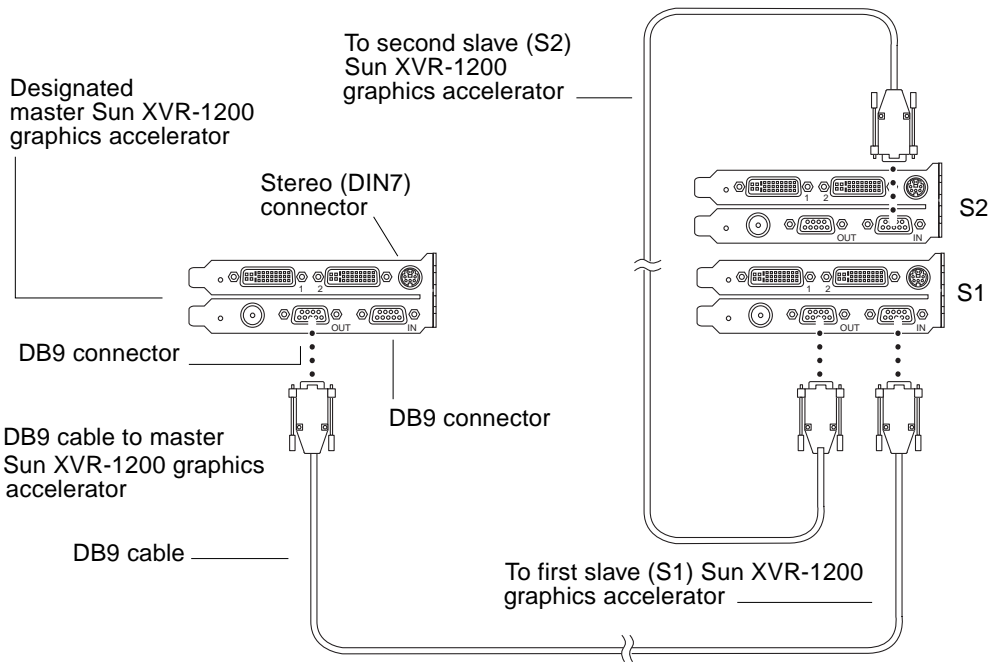

FIGURE 6-2 Frame lock Cabling Through the DB9 Connector

Stereo DIN7 Port Framelock Cable

The stereo DIN7 port framelock cable, FIGURE 6-3, is a Y-shaped cable with three connectors for framelocking through the stereo DIN7 connectors. Use this assembly to daisy-chain multiple Sun XVR-1200 graphics accelerators.

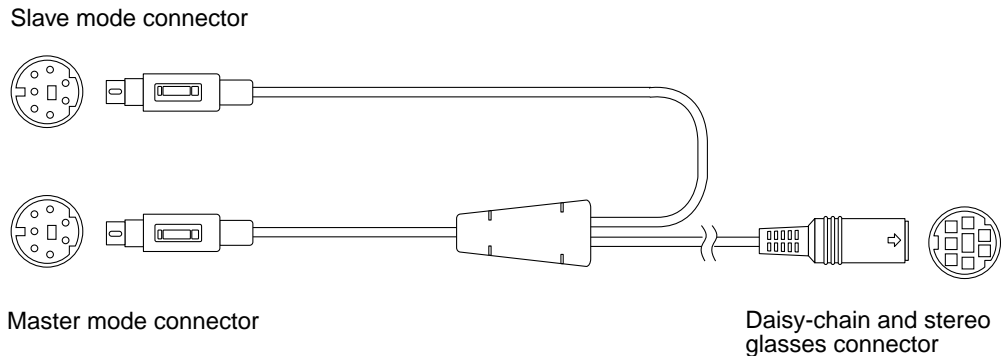

FIGURE 6-3 Stereo DIN7 Port Framelock Cable

TABLE 6-1 Stereo DIN7 Port Framelock Cable Connections

Framelock Connector	Description
Master connector (shortest male cable)	Connects into the stereo connector located on the Sun XVR-1200 graphics accelerator that is designated as the master device. Also plugs into the daisy-chain connector for slave Sun XVR-1200 graphics accelerators.
Slave connector (longest male cable)	Connects into the stereo connector located on the Sun XVR-1200 graphics accelerator that is designated as a slave device.
Daisy-chain/stereo glasses connector (female connector)	Can connect a pair of stereo glasses directly into this connector. Or the connector can be used to daisy-chain to other framelock cables for additional slave Sun XVR-1200 graphics accelerator devices.

Note – There can only be one master Sun XVR-1200 graphics accelerator device. You must configure all other Sun XVR-1200 graphics accelerator devices as slaves. See the section “Configuring Graphics Accelerators for Framelocking” on page 50.

Connecting the Stereo Port Framelock Cable

Cable the Sun graphics accelerators to be framelocked before configuring your system for framelock (described in “Configuring Graphics Accelerators for Framelocking” on page 50).

1. Locate the master Sun XVR-1200 graphics accelerator I/O backplate on the rear of your system and its stereo/framelock DIN7 connector (FIGURE 6-4).

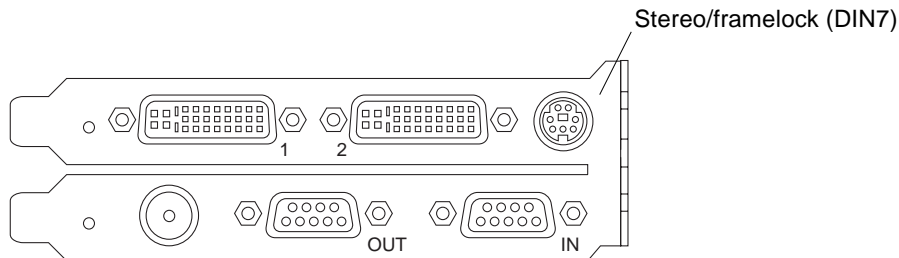

FIGURE 6-4 Sun XVR-1200 Graphics Accelerator Stereo/Framelock Connector

2. Connect the framelock cable master connector to the stereo/framelock DIN7 connector (FIGURE 6-5).
3. Connect the slave cable connector to a slave Sun XVR-1200 graphics accelerator stereo/framelock DIN7 connector.
4. If you are synchronizing additional Sun XVR-1200 graphics accelerators,
 - a. Connect an additional framelock cable master connector to the framelock cable daisy-chain/stereo connector (FIGURE 6-5).
 - b. Connect the new slave cable connector to the next graphics board to be framelocked. Stereo glasses may be attached to the final daisy-chain/stereo connector.

Note – The Sun XVR-1200 graphics accelerator supports both tethered and wireless stereo glasses. For wireless stereo glasses, connect the transmitter DIN7 connector to the Sun XVR-1200 graphics accelerator stereo/framelock DIN7 connector or to the framelock cable daisy-chain/stereo connector.

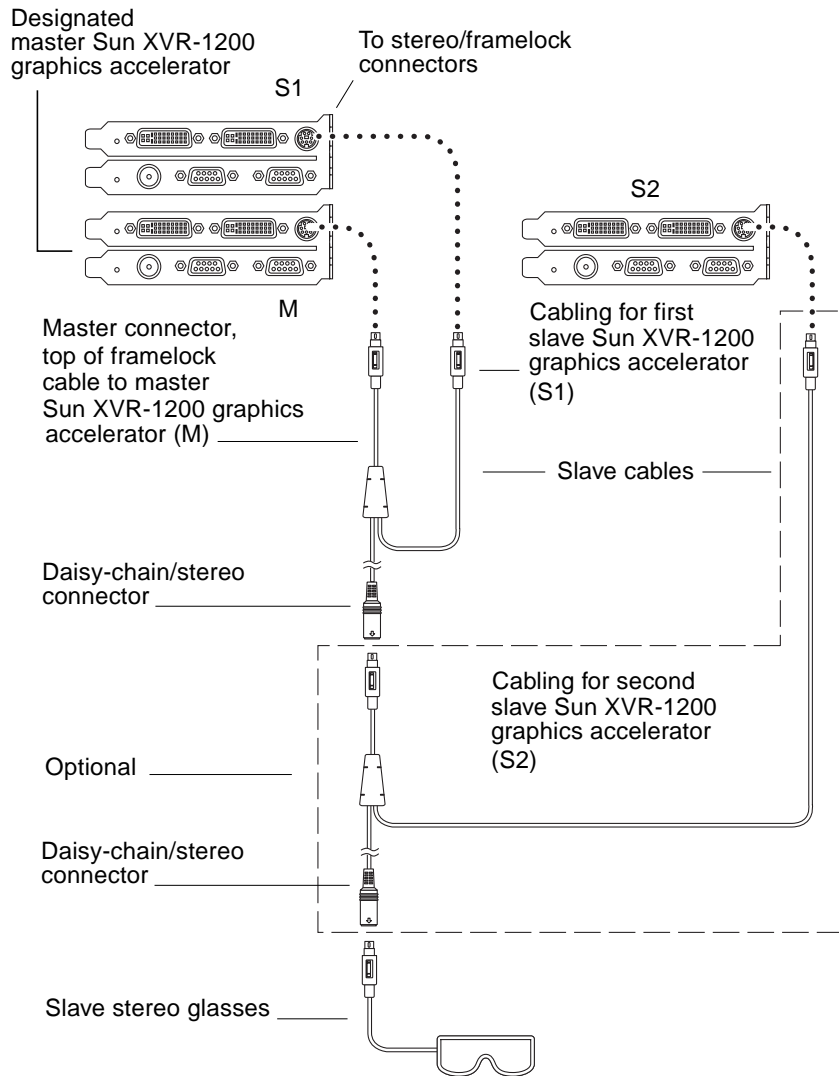

FIGURE 6-5 Frame-lock Cabling Through the Stereo DIN7 Port

Configuring Graphics Accelerators for Framelocking

The device name for the Sun XVR-1200 graphics accelerator is `jfb`.

1. Designate a Sun XVR-1200 graphics accelerator as the master.

You may use the Sun XVR-1200 graphics accelerator that serves as the boot/console head for that system.

You may select any device (that is, `jfb0`, `jfb1`, ... and so on) to be the master Sun XVR-1200 graphics accelerator device.

2. Make sure that each Sun XVR-1200 graphics accelerator installed is running a video format with an identical frame refresh rate to the video format running on the Sun XVR-1200 graphics accelerator in master mode.

a. Check the resolution of a Sun XVR-1200 graphics accelerator by using the `fbconfig` command.

For example:

```
host% fbconfig -dev jfb0 -prconf
```

You must repeat this command for each Sun XVR-1200 graphics accelerator in the system or systems.

b. Change the resolution of a Sun XVR-1200 graphics accelerator using the `fbconfig` command.

If the resolution on each Sun XVR-1200 graphics accelerator is not the same, you must change it to match the Sun XVR-1200 graphics accelerator in master mode. You must configure each board separately (that is, for `jfb0`, `jfb1`, and so on).

For example:

```
host% fbconfig -dev jfb0 -res 1280x1024x76
host% fbconfig -dev jfb1 -res 1280x1024x76
```

Log out of the X window system, and then log back in for the resolutions to take effect.

3. Connect the framelock cables to each Sun graphics accelerator to be framelocked.

Note – Do not enable any stream to be a slave without the framelock cable connected. Be sure the framelock cable slave connector is attached to the graphics board configured as a slave.

Make sure to first connect the framelock cable to the master graphics accelerator.

4. Set the slave graphics boards.

For example,

```
host% fbconfig -dev jfb1 -slave stereo
```

Setting the Default Console Display

These instructions describe how to set the Sun XVR-1200 graphics accelerator as the default monitor console display.

Note – Only the DVI-1 connector labeled “1” can be used as the console output.

1. At the ok prompt, type:

```
ok show-displays
```

Information similar to the text below is displayed:

```
a) /pci@1f,0/SUNW,m64B@13
b) /pci@8,700000/SUNW,XVR-1200@1
q) NO SELECTION
Enter Selection, q to quit: b
```

2. Select the graphics board you want to be the default console display.

In the above example, we typed **b** for the Sun XVR-1200 graphics accelerator. Your selection is confirmed by the following output:

```
/pci@8,700000/SUNW,XVR-1200@1 has been selected.
Type ^Y ( Control-Y ) to insert it in the command line.
e.g. ok nvalias mydev ^Y
    for creating devalias mydev for /pci@8,700000/SUNW,XVR-1200@1
```

3. Create an alias name for the Sun XVR-1200 device:

This step is optional for all systems. Creating the alias, however, will simplify future OpenBoot PROM commands.

a. Use `nvalias` to name the Sun XVR-1200 graphics accelerator device.

This example uses `mydev` as the device.

```
ok nvalias mydev (Control-Y)
```

Complete the line entry by pressing Control-Y on your keyboard (that is, press and hold Control and press the Y key) and then Return. The output displays as:

```
ok nvalias mydev /pci@8,700000/SUNW,XVR-1200@10
```

b. Verify the alias.

```
ok devalias  
mydev                /pci@8,700000/SUNW,XVR-1200@1  
screen                /pci@8,700000/SUNW,XVR-1200@1  
mouse                /pci@9,700000/usb@1,3/mouse@2  
keyboard             /pci@9,700000/usb@1,3/keyboard@1  
....
```

In the above output, both `mydev` and `screen` are mapped to `/pci@8,700000/SUNW,XVR-1200@1` and are therefore interchangeable alias names.

In this procedure example, you can now refer to `mydev` as the Sun XVR-1200 graphics accelerator device, as shown in the next step.

4. Set the selected device to be the default console display.

For example,

```
ok setenv output-device mydev  
output-device = mydev
```

Without Step 3 (creating an alias name), you will need to type the entire device name precisely. In this example, you would need to enter the following:

```
ok setenv output-device /pci@8,700000/SUNW,XVR-1200@1  
output-device = /pci@8,700000/SUNW,XVR-1200@1
```

5. Reset the system using the new `output-device` as the console:

```
ok reset-all
```

6. Connect your monitor cable to the Sun XVR-1200 graphics accelerator on your system back panel.
7. To set a resolution (for example, $1280 \times 1024 \times 112$), type:

```
ok setenv output-device mydev:r1280x1024x112
output-device=mydev:r1280x1024x112
```

Reset the system:

```
ok reset-all
```

You can get a list of available resolutions for your display device by typing the following:

```
ok cd /pci@8,700000/SUNW,XVR-1200@1
ok .screen-resolutions
```

Sun XVR-1200 Graphics Accelerator Specifications

This appendix provides I/O port specifications for the Sun XVR-1200 graphics accelerator.

- "I/O Port Specifications" on page 57
- "DVI Video Connector" on page 58
- "DB9 Video Connector" on page 60
- "Stereo Connector" on page 62
- "External Video Synchronization BNC Connector" on page 63

I/O Port Specifications

The external I/O ports are accessible through the I/O connectors on the Sun XVR-1200 graphics accelerator backplate (FIGURE B-1).

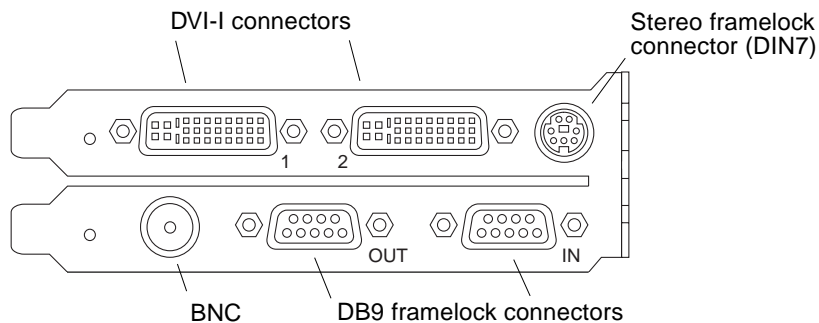

FIGURE B-1 Sun XVR-1200 Graphics Accelerator I/O Connectors

DVI Video Connector

FIGURE B-2 and TABLE B-4 shows the Sun XVR-1200 graphics accelerator DVI connector and pinout signals. The DVI video connector is a 30-pin connector for a supported workstation monitor. The DVI video connector supports both analog and digital resolutions, but both cannot be used simultaneously from the individual DVI connector.

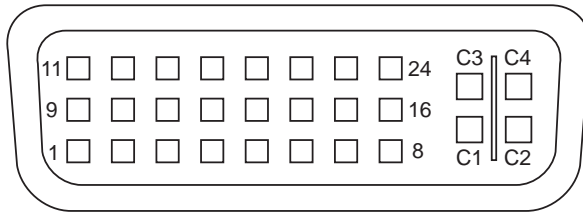

FIGURE B-2 Sun XVR-1200 Graphics Accelerator DVI Connector

TABLE B-1 Sun XVR-1200 Graphics Accelerator DVI Video Output Connector

Pin	Signal
1	TMDS Data2-
2	TMDS Data2+
3	TMDS Data2/4 Shield
4	No connect
5	No connect
6	DDC Clock (SCL)
7	DDC Bi-directional Data (SDA)
8	Analog vertical sync
9	TMDS Data1-
10	TMDS Data1+
11	TMDS Data1/3 Shield
12	No connect
13	No connect
14	+5V CD power

TABLE B-1 Sun XVR-1200 Graphics Accelerator DVI Video Output Connector (*Continued*)

Pin	Signal
15	GND Return: +5V, Hsync, Vsync
16	Hot Plug Detect
17	TMDS Data0-
18	TMDS Data0+
19	TMDS Data0/5 shield
20	No connect
21	No connect
22	TMDS Clock shield
23	TMDS Clock+
24	TMDS Clock-
C1	Analog Red
C2	Analog Green
C3	Analog Blue
C4	Analog Horizontal Sync
C5	Analog GND Return: (analog R, G, B)

DB9 Video Connector

FIGURE B-3, TABLE B-2, and TABLE B-3 show the Sun XVR-1200 graphics accelerator DB9 connector and pinout signals. The DB9 connector is used to framelock two or more Sun XVR-1200 graphics accelerator subsystems for viewing over multiple displays. See “Sun XVR-1200 Graphics Accelerator Framelock System” on page 43.

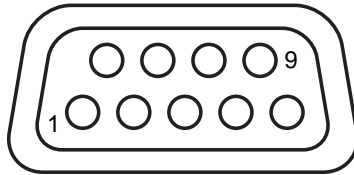

FIGURE B-3 Sun XVR-1200 Graphics Accelerator DB9 Connector

TABLE B-2 Sun XVR-1200 Graphics Accelerator DB9 Connector-Multiview In

Pin	Signal
1	Slave sense
2	Ground
3	RefClk Input
4	RefClk Input
5	Ground
6	Release Input
7	Pixel Align Input
8	Ground
9	Done Input

TABLE B-3 Sun XVR-1200 Graphics Accelerator DB9 Connector-Multiview Out

Pin	Signal
1	3.3V (Fuse - 0.5A limit)
2	Ground
3	RefClk Output
4	RefClk Output
5	Ground
6	Release Output
7	Pixel Align Output
8	Ground
9	Done Output

Stereo Connector

FIGURE B-4 and TABLE B-4 shows the Sun XVR-1200 graphics accelerator stereo DIN7 connector and pinout signals.

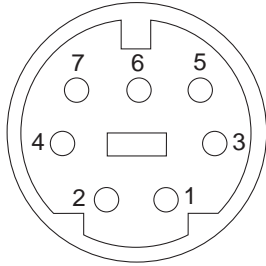

FIGURE B-4 Sun XVR-1200 Graphics Accelerator 7-Pin DIN Female Stereo Connector

TABLE B-4 Sun XVR-1200 Graphics Accelerator Stereo DIN7 Connector Pinout

Pin	Signal
1	Signal ground
2	5.0V (Fused, supplies up to 300mA, limited to 1.0A)
3	12.0V (Fused, supplies up to 300mA, limited to 1.0A)
4	Stereo sync
5	Frameclock In
6	No connection
7	No connection

External Video Synchronization BNC Connector

The external video synchronization connector uses a 75-Ohm BNC male connector. A 75-Ohm coax cable terminated with a female BNC connector is needed to connect to this port and provide a periodic signal to which the display system attempts to lock its vertical refresh rate.

The supported formats are:

- NTSC composite video
- PAL composite video
- TTL, LVTTTL, or CMOS level compatible periodic signal (50 Hz 180 Hz), with a minimum low or high pulse or 100ns (TBV)

Sun XVR-1200 Graphics Accelerator Graphics Library Extensions

This appendix lists the Sun OpenGL for Solaris graphics library extensions for the Sun XVR-1200 graphics accelerator. See <http://www.opengl.org> for detailed information on using the following graphics library extensions.

Sun OpenGL 1.3 for Solaris Extensions

The Sun XVR-1200 graphics accelerator supports the following Sun OpenGL 1.3 for Solaris extensions:

- `GL_ARB_texture_compression` – Texture compression extension
- `GL_ARB_texture_cube_map` – Cube map texture extension
- `GL_EXT_blend_func_separate` – Separate blend function extension
- `GL_SGIS_texture_border_clamp` – Texture border clamp extension
- `GL_SUN_blend_src_mult_dst_alpha` – Defines two alpha blending factors: `GL_SRC_ALPHA_MULT_ONE_MINUS_DST_ALPHA_SUN` and `GL_SRC_ALPHA_MULT_DST_ALPHA_SUN`, used as the source RGB blending factors to perform Porter-Duff blending

Sun OpenGL 1.2.3 for Solaris Extensions

The Sun XVR-1200 graphics accelerator supports the following Sun OpenGL 1.2.3 for Solaris extensions:

- `GL_ARB_multitexture` – Multitexture extension
- `GL_ARB_texture_border_clamp` – Texture border clamp extension
- `GL_ARB_texture_env_combine` – Texture combiner operations extension
- `GL_ARB_transpose_matrix` – Transpose matrix extension
- `GL_EXT_abgr` – ABGR reverse-order color format extension
- `GL_EXT_gradient_clear` – Gradient clear extension
- `GL_EXT_multi_draw_arrays` – Multidraw array and element extensions
- `GL_EXT_polygon_offset` – Polygon offset extension
- `GL_EXT_rescale_normal` – Rescale normal extension
- `GL_EXT_texture_env_combine` – Texture environment combine extension
- `GL_EXT_texture3D` – 3D texture mapping extension
- `GL_HP_occlusion_test` – Occlusion culling extension
- `GL_SGI_color_table` – SGI color table extension
- `GL_SGI_texture_color_table` – Texture color table extension
- `GL_SUN_global_alpha` – Global alpha extension
- `GL_SUN_get_transparent_index` – Transparent pixel index extension
- `GL_SUN_multi_draw_arrays` – Multidraw array and element extension
- `GL_SUN_vertex` – Vertex extension
- `GL_SUNX_constant_data` – Constant data extension

Index

A

antialiasing, multisample, 37
available, 38

B

backplate, 3, 57
BNC connector, 57, 63

C

cables
 DB9 port framelock, 45
 DVI-I to 13W3, 26
 DVI-I to HD-15, 26
 stereo framelock, 47, 48, 49
 stereo port framelock, 47
CD directories, 10
changing resolutions, 27
 SUNWjfb_config man page, 27
configuring framelock, 50
configuring multiple frame buffers, 29
 Xinerama, 31
 Xservers file, 29
console display, setting default, 53

D

DB9 port

 connecting framelock cable, 45, 46
 framelock cable, 44
 framelocking, 44
DB9 video connector, 57
default console, setting, 53, 54
-defdepth, 39
DIN7 stereo connector, 57, 62
DVI video connector, 57, 58, 60
DVI-I to 13W3 cable, 26
DVI-I to HD-15 cable, 26
dynamic multisample antialiasing, 37
 enabling all OpenGL applications, 37
 -samples, 38

F

fan card, Sun Fire 6800 system, 25
fbconfig, 18
 -defdepth, 39
 -list, 5, 18
 -offset xval yval, 35
 -prconf, 41
 -propt, 40
 -slave, 51
features, 33
forceon, 38
framelocking, 43
 configuring, 50
 DB9 port, 43, 44, 45, 46
 ordering cables, 44
 stereo framelock cable, 44, 47

- stereo port, 43, 48, 49
- synchronization, 43

FRU ID, 7

G

- graphics library extensions, 65
 - OpenGL 1.2.3, 66
 - OpenGL 1.3, 65

H

- hardware installation, 21
 - Sun Blade 2000 system, 23
 - Sun Fire 6800 system, 24

I

- I/O assembly, 24
- I/O backplate, 3
- I/O connector pinout, 57
 - DB9 video connector, 57
 - DVI video connector, 57, 58, 60
 - stereo DIN7 connector, 57, 62
- installation process, 6
- installing software, 15
 - ./install, 15

L

- library extensions, graphics, 65
- list, 5, 18

M

- man pages, 18
 - fbconfig, 18
 - SUNWjfb_config, 19
- monitor cables, 26
- multiple frame buffers, configuring, 29
- multiple monitors
 - configuration, 29
- multisample, 37

- multisampling
 - available, 38
 - disable, 38
 - disabling, 39
 - forceon, 38
 - multisample, 38

O

- offset xval yval, 35
- OpenGL 1.2.3 library extensions, 66
- OpenGL 1.3 library extensions, 65
- OpenGL software packages, 12

P

- PCI I/O assembly, 24
- pinouts, I/O connectors, 57
- platform documentation, 22
- prconf, 41
- propt, 40

R

- removing software, 17
 - ./remove, 17
- resolutions, 5
 - changing, 27

S

- sample sizes, multisampling, 38
- screen resolutions, 5
- setting default console, 53, 54
- slave stereo, 51
- software installation, 9
- software packages, 10
- software patches, 11, 14
- software requirements, 9
- stereo DIN7 connector, 57, 62
- stereo framelock cable, 47
- stereo port
 - connecting stereo framelock cable, 48, 49

- framelock cable, 47
- Sun Blade 2000 system, 23
- Sun Fire 6800 system, 24
 - fan card, 25
 - I/O assembly, 24
- Sun OpenGL for Solaris library extensions, 65
- Sun OpenGL for Solaris package names, 12, 13
- Sun XVR-1200 graphics accelerator, 1
 - backplate, 3
 - BNC connector, 63
 - CD directories, 10
 - changing resolutions, 27
 - configuring framelock, 50
 - DB9 video connector, 57
 - DB9/framelock connector, 45
 - DVI video connector, 57, 58, 60
 - features, 3, 33
 - framelocking, 43
 - FRU ID, 7
 - graphics library extensions, 65, 66
 - hardware installation, 21, 23, 24
 - I/O connector pinouts, 57
 - installation kit, 1
 - installation process, 6
 - installing software, 15
 - man pages, 18
 - multisample antialiasing, 37
 - overview, 2
 - removing software, 17
 - setting default console, 53, 54
 - software installation, 9
 - software packages, 10
 - software patches, 11, 14
 - stereo DIN7 connector, 57, 62
 - Sun OpenGL for Solaris packages, 12
 - technical support, 7
 - video formats, 5
 - video streaming methods, 33
 - Xservers file, 29
- SUNWjfb_config, 19

T

- technical support, 7

V

- video formats, 5
- video streaming methods, 33
 - configuration options, 35, 39
 - single video output, 34
 - two independent video streams, 36
 - two video streams, one large frame buffer, 35

X

- Xinerama, 31
 - restrictions, 32
 - using, 31
- Xservers file, 29

