



Sun StorEdge™ 3900 and 6900 Series 1.1 Installation Guide

Sun Microsystems, Inc.
4150 Network Circle
Santa Clara, CA 95054 U.S.A.
650-960-1300

Part No. 816-5252-10
July 2002, [Revision A](#)

[Send comments about this document to: docfeedback@sun.com](mailto:docfeedback@sun.com)

Copyright 2002 Sun Microsystems, Inc., 4150 Network Circle • Santa Clara, CA 95054 USA. All rights reserved.

This product or document is protected by copyright and distributed under licenses restricting its use, copying, distribution, and decompilation. No part of this product or document may be reproduced in any form by any means without prior written authorization of Sun and its licensors, if any. Third-party software, including font technology, is copyrighted and licensed from Sun suppliers.

Parts of the product may be derived from Berkeley BSD systems, licensed from the University of California. UNIX is a registered trademark in the U.S. and other countries, exclusively licensed through X/Open Company, Ltd. For Netscape Communicator™, the following notice applies: Copyright 1995 Netscape Communications Corporation. All rights reserved.

Sun, Sun Microsystems, the Sun logo, StorEdge, and Solaris are trademarks, registered trademarks, or service marks of Sun Microsystems, Inc. in the U.S. and other countries.

The OPEN LOOK and Sun™ Graphical User Interface was developed by Sun Microsystems, Inc. for its users and licensees. Sun acknowledges the pioneering efforts of Xerox in researching and developing the concept of visual or graphical user interfaces for the computer industry. Sun holds a non-exclusive license from Xerox to the Xerox Graphical User Interface, which license also covers Sun's licensees who implement OPEN LOOK GUIs and otherwise comply with Sun's written license agreements.

RESTRICTED RIGHTS: Use, duplication, or disclosure by the U.S. Government is subject to restrictions of FAR 52.227-14(g)(2)(6/87) and FAR 52.227-19(6/87), or DFAR 252.227-7015(b)(6/95) and DFAR 227.7202-3(a).

DOCUMENTATION IS PROVIDED "AS IS" AND ALL EXPRESS OR IMPLIED CONDITIONS, REPRESENTATIONS AND WARRANTIES, INCLUDING ANY IMPLIED WARRANTY OF MERCHANTABILITY, FITNESS FOR A PARTICULAR PURPOSE OR NON-INFRINGEMENT, ARE DISCLAIMED, EXCEPT TO THE EXTENT THAT SUCH DISCLAIMERS ARE HELD TO BE LEGALLY INVALID.

Copyright 2002 Sun Microsystems, Inc., 4150 Network Circle • Santa Clara, CA 95054 Etats-Unis. Tous droits réservés.

Ce produit ou document est protégé par un copyright et distribué avec des licences qui en restreignent l'utilisation, la copie, la distribution, et la décompilation. Aucune partie de ce produit ou document ne peut être reproduite sous aucune forme, par quelque moyen que ce soit, sans l'autorisation préalable et écrite de Sun et de ses bailleurs de licence, s'il y en a. Le logiciel détenu par des tiers, et qui comprend la technologie relative aux polices de caractères, est protégé par un copyright et licencié par des fournisseurs de Sun.

Des parties de ce produit pourront être dérivées des systèmes Berkeley BSD licenciés par l'Université de Californie. UNIX est une marque déposée aux Etats-Unis et dans d'autres pays et licenciée exclusivement par X/Open Company, Ltd. La notice suivante est applicable à Netscape Communicator™: Copyright 1995 Netscape Communications Corporation. Tous droits réservés.

Sun, Sun Microsystems, the Sun logo, StorEdge, et Solaris sont des marques de fabrique ou des marques déposées, ou marques de service, de Sun Microsystems, Inc. aux Etats-Unis et dans d'autres pays.

L'interface d'utilisation graphique OPEN LOOK et Sun™ a été développée par Sun Microsystems, Inc. pour ses utilisateurs et licenciés. Sun reconnaît les efforts de pionniers de Xerox pour la recherche et le développement du concept des interfaces d'utilisation visuelle ou graphique pour l'industrie de l'informatique. Sun détient une licence non exclusive de Xerox sur l'interface d'utilisation graphique Xerox, cette licence couvrant également les licenciés de Sun qui mettent en place l'interface d'utilisation graphique OPEN LOOK et qui en outre se conforment aux licences écrites de Sun.

CETTE PUBLICATION EST FOURNIE "EN L'ETAT" ET AUCUNE GARANTIE, EXPRESSE OU IMPLICITE, N'EST ACCORDEE, Y COMPRIS DES GARANTIES CONCERNANT LA VALEUR MARCHANDE, L'APTITUDE DE LA PUBLICATION A REpondre A UNE UTILISATION PARTICULIERE, OU LE FAIT QU'ELLE NE SOIT PAS CONTREFAISANTE DE PRODUIT DE TIERS. CE DENI DE GARANTIE NE S'APPLIQUERAIT PAS, DANS LA MESURE OU IL SERAIT TENU JURIDIQUEMENT NUL ET NON AVENU.



Safety Agency Compliance Statements

Read this section before beginning any procedure. The following text provides safety precautions to follow when installing a Sun Microsystems product.

Safety Precautions

For your protection, observe the following safety precautions when setting up your equipment:

- Follow all cautions and instructions marked on the equipment.
- Ensure that the voltage and frequency of your power source match the voltage and frequency inscribed on the equipment's electrical rating label.
- Never push objects of any kind through openings in the equipment. Dangerous voltages may be present. Conductive foreign objects could produce a short circuit that could cause fire, electric shock, or damage to your equipment.

Symbols

The following symbols may appear in this book:



Caution – There is a risk of personal injury and equipment damage. Follow the instructions.



Caution – Hot surface. Avoid contact. Surfaces are hot and may cause personal injury if touched.



Caution – Hazardous voltages are present. To reduce the risk of electric shock and danger to personal health, follow the instructions.



Caution – Applies AC power to the system.

Depending on the type of power switch your device has, one of the following symbols may be used:



Caution – Removes AC power from the system.



Caution – The On/Standby switch is in the standby position.

Modifications to Equipment

Do not make mechanical or electrical modifications to the equipment. Sun Microsystems is not responsible for regulatory compliance of a modified Sun product.

Placement of a Sun Product



Caution – Do not block or cover the openings of your Sun product. Never place a Sun product near a radiator or heat register. Failure to follow these guidelines can cause overheating and affect the reliability of your Sun product.



Caution – The workplace-dependent noise level defined in DIN 45 635 Part 1000 must be 70Db(A) or less.

SELV Compliance

Safety status of I/O connections comply to SELV requirements.

Power Cord Connection



Caution – Sun products are designed to work with single-phase power systems having a grounded neutral conductor. To reduce the risk of electric shock, do not plug Sun products into any other type of power system. Contact your facilities manager or a qualified electrician if you are not sure what type of power is supplied to your building.



Caution – Not all power cords have the same current ratings. Household extension cords do not have overload protection and are not meant for use with computer systems. Do not use household extension cords with your Sun product.



Caution – Your Sun product is shipped with a grounding type (three-wire) power cord. To reduce the risk of electric shock, always plug the cord into a grounded power outlet

The following caution applies only to devices with a Standby power switch:



Caution – The power switch of this product functions as a standby type device only. The power cord serves as the primary disconnect device for the system. Be sure to plug the power cord into a grounded power outlet that is nearby the system and is readily accessible. Do not connect the power cord when the power supply has been removed from the system chassis.

Lithium Battery



Caution – On Sun CPU boards, there is a lithium battery molded into the real-time clock, SGS No. MK48T59Y, MK48TXXB-XX, MK48T18-XXXPCZ, M48T59W-XXXPCZ, or MK48T08. Batteries are not customer replaceable parts. They may explode if mishandled. Do not dispose of the battery in fire. Do not disassemble it or attempt to recharge it.

Battery Pack



Caution – There is a sealed lead acid battery in Sun StorEdge 3900 and 6900 series units. Portable Energy Products No. TLC02V50. There is danger of explosion if the battery pack is mishandled or incorrectly replaced. Replace only with the same type of Sun Microsystems battery pack. Do not disassemble it or attempt to recharge it outside the system. Do not dispose of the battery in fire. Dispose of the battery properly in accordance with local regulations

System Unit Cover

You must remove the cover of your Sun computer system unit to add cards, memory, or internal storage devices. Be sure to replace the top cover before powering on your computer system.



Caution – Do not operate Sun products without the top cover in place. Failure to take this precaution may result in personal injury and system damage.

Laser Compliance Notice

Sun products that use laser technology comply with Class 1 laser requirements.

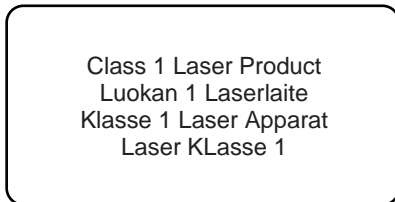

CD-ROM



Caution – Use of controls, adjustments, or the performance of procedures other than those specified herein may result in hazardous radiation exposure.

Einhaltung sicherheitsbehördlicher Vorschriften

Auf dieser Seite werden Sicherheitsrichtlinien beschrieben, die bei der Installation von Sun-Produkten zu beachten sind.

Sicherheitsvorkehrungen

Treffen Sie zu Ihrem eigenen Schutz die folgenden Sicherheitsvorkehrungen, wenn Sie Ihr Gerät installieren:

- Beachten Sie alle auf den Geräten angebrachten Warnhinweise und Anweisungen.
- Vergewissern Sie sich, daß Spannung und Frequenz Ihrer Stromquelle mit der Spannung und Frequenz übereinstimmen, die auf dem Etikett mit den elektrischen Nennwerten des Geräts angegeben sind.
- Stecken Sie auf keinen Fall irgendwelche Gegenstände in Öffnungen in den Geräten. Leitfähige Gegenstände könnten aufgrund der möglicherweise vorliegenden gefährlichen Spannungen einen Kurzschluß verursachen, der einen Brand, Stromschlag oder Geräteschaden herbeiführen kann.

Symbole

Die Symbole in diesem Handbuch haben folgende Bedeutung:



Achtung – Gefahr von Verletzung und Geräteschaden. Befolgen Sie die Anweisungen



Achtung – Hohe Temperatur. Nicht berühren, da Verletzungsgefahr durch heiße Oberfläche besteht.



Achtung – Gefährliche Spannungen. Anweisungen befolgen, um Stromschläge und Verletzungen zu vermeiden



Achtung – Setzt das System unter Wechselstrom

Je nach Netzschaltertyp an Ihrem Gerät kann eines der folgenden Symbole benutzt werden:



Achtung – Unterbricht die Wechselstromzufuhr zum Gerät.



Achtung – (Stand-by-Position) - Der Ein-/Wartezustand-Schalter steht auf Wartezustand. Änderungen an Sun-Geräten.

Nehmen Sie keine mechanischen oder elektrischen Änderungen an den Geräten vor. Sun Microsystems, übernimmt bei einem Sun-Produkt, das geändert wurde, keine Verantwortung für die Einhaltung behördlicher Vorschriften

Aufstellung von Sun-Geräten



Achtung – Um den zuverlässigen Betrieb Ihres Sun-Geräts zu gewährleisten und es vor Überhitzung zu schützen, dürfen die Öffnungen im Gerät nicht blockiert oder verdeckt werden. Sun-Produkte sollten niemals in der Nähe von Heizkörpern oder Heizluftklappen aufgestellt werden



Achtung – Der arbeitsplatzbezogene Schalldruckpegel nach DIN 45 635 Teil 1000 beträgt 70Db(A) oder weniger.

Einhaltung der SELV-Richtlinien

Die Sicherung der I/O-Verbindungen entspricht den Anforderungen der SELV-Spezifikation.

Anschluß des Netzkabels



Achtung – Sun-Produkte sind für den Betrieb an Einphasen-Stromnetzen mit geerdetem Nulleiter vorgesehen. Um die Stromschlaggefahr zu reduzieren, schließen Sie Sun-Produkte nicht an andere Stromquellen an. Ihr Betriebsleiter oder ein qualifizierter Elektriker kann Ihnen die Daten zur Stromversorgung in Ihrem Gebäude geben.



Achtung – Nicht alle Netzkabel haben die gleichen Nennwerte. Herkömmliche, im Haushalt verwendete Verlängerungskabel besitzen keinen Überlastungsschutz und sind daher für Computersysteme nicht geeignet.



Achtung – Ihr Sun-Gerät wird mit einem dreiadrigen Netzkabel für geerdete Netzsteckdosen geliefert. Um die Gefahr eines Stromschlags zu reduzieren, schließen Sie das Kabel nur an eine fachgerecht verlegte, geerdete Steckdose an.

Die folgende Warnung gilt nur für Geräte mit Wartezustand-Netzschalter:



Achtung – Der Ein/Aus-Schalter dieses Geräts schaltet nur auf Wartezustand (Stand-By-Modus). Um die Stromzufuhr zum Gerät vollständig zu unterbrechen, müssen Sie das Netzkabel von der Steckdose abziehen. Schließen Sie den Stecker des Netzkabels an eine in der Nähe befindliche, frei zugängliche, geerdete Netzsteckdose an. Schließen Sie das Netzkabel nicht an, wenn das Netzteil aus der Systemeinheit entfernt wurde.

Lithiumbatterie



Achtung – CPU-Karten von Sun verfügen über eine Echtzeituhr mit integrierter Lithiumbatterie (Teile-Nr. MK48T59Y, MK48TXXB-XX, MK48T18-XXXPCZ, M48T59W-XXXPCZ, oder MK48T08). Diese Batterie darf nur von einem qualifizierten Servicetechniker ausgewechselt werden, da sie bei falscher Handhabung explodieren kann. Werfen Sie die Batterie nicht ins Feuer. Versuchen Sie auf keinen Fall, die Batterie auszubauen oder wiederaufzuladen.

Batterien



Achtung – Die Geräte Sun StorEdge 3900 and 6900 series enthalten auslaufsichere Bleiakkumulatoren. Produkt-Nr. TLC02V50 für portable Stromversorgung. Werden bei der Behandlung oder beim Austausch der Batterie Fehler gemacht, besteht Explosionsgefahr. Batterie nur gegen Batterien gleichen Typs von Sun Microsystems austauschen. Nicht demontieren und nicht versuchen, die Batterie außerhalb des Geräts zu laden. Batterie nicht ins Feuer werfen. Ordnungsgemäß entsprechend den vor Ort geltenden Vorschriften entsorgen.

Gehäuseabdeckung

Sie müssen die obere Abdeckung Ihres Sun-Systems entfernen, um interne Komponenten wie Karten, Speicherchips oder Massenspeicher hinzuzufügen. Bringen Sie die obere Gehäuseabdeckung wieder an, bevor Sie Ihr System einschalten.



Achtung – Bei Betrieb des Systems ohne obere Abdeckung besteht die Gefahr von Stromschlag und Systemschäden.

Einhaltung der Richtlinien für Laser

Sun-Produkte, die mit Laser-Technologie arbeiten, entsprechen den Anforderungen der Laser Klasse 1.

Class 1 Laser Product
Luokan 1 Laserlaite
Klasse 1 Laser Apparat
Laser K Klasse 1

CD-ROM



Achtung – Die Verwendung von anderen Steuerungen und Einstellungen oder die Durchführung von Prozeduren, die von den hier beschriebenen abweichen, können gefährliche Strahlungen zur Folge haben.

Conformité aux normes de sécurité

Ce texte traite des mesures de sécurité qu'il convient de prendre pour l'installation d'un produit Sun Microsystems.

Mesures de sécurité

Pour votre protection, veuillez prendre les précautions suivantes pendant l'installation du matériel :

- Suivre tous les avertissements et toutes les instructions inscrites sur le matériel.

- Vérifier que la tension et la fréquence de la source d'alimentation électrique correspondent à la tension et à la fréquence indiquées sur l'étiquette de classification de l'appareil.
- Ne jamais introduire d'objets quels qu'ils soient dans une des ouvertures de l'appareil. Vous pourriez vous trouver en présence de hautes tensions dangereuses. Tout objet conducteur introduit de la sorte pourrait produire un court-circuit qui entraînerait des flammes, des risques d'électrocution ou des dégâts matériels.

Symboles

Vous trouverez ci-dessous la signification des différents symboles utilisés :



Attention – risques de blessures corporelles et de dégâts matériels. Veuillez suivre les instructions.



Attention – surface à température élevée. Évitez le contact. La température des surfaces est élevée et leur contact peut provoquer des blessures corporelles.



Attention – présence de tensions dangereuses. Pour éviter les risques d'électrocution et de danger pour la santé physique, veuillez suivre les instructions.



Attention – Votre système est sous tension (courant alternatif).

Un des symboles suivants sera peut-être utilisé en fonction du type d'interrupteur de votre système:



Attention – Votre système est hors tension (courant alternatif).



Attention – L'interrupteur Marche/Veilleuse est en position « Veilleuse ».

Modification du matériel

Ne pas apporter de modification mécanique ou électrique au matériel. Sun Microsystems n'est pas responsable de la conformité réglementaire d'un produit Sun qui a été modifié.

Positionnement d'un produit Sun



Attention – pour assurer le bon fonctionnement de votre produit Sun et pour l'empêcher de surchauffer, il convient de ne pas obstruer ni recouvrir les ouvertures prévues dans l'appareil. Un produit Sun ne doit jamais être placé à proximité d'un radiateur ou d'une source de chaleur.



Attention – Le niveau de pression acoustique au poste de travail s'élève selon la norme DIN 45 635 section 1000, à 70 dB (A) ou moins.

Conformité SELV

Sécurité : les raccordements E/S sont conformes aux normes SELV.

Connexion du cordon d'alimentation



Attention – les produits Sun sont conçus pour fonctionner avec des alimentations monophasées munies d'un conducteur neutre mis à la terre. Pour écarter les risques d'électrocution, ne pas brancher de produit Sun dans un autre type d'alimentation secteur. En cas de doute quant au type d'alimentation électrique du local, veuillez vous adresser au directeur de l'exploitation ou à un électricien qualifié.



Attention – tous les cordons d'alimentation n'ont pas forcément la même puissance nominale en matière de courant. Les rallonges d'usage domestique n'offrent pas de protection contre les surcharges et ne sont pas prévues pour les systèmes d'ordinateurs. Ne pas utiliser de rallonge d'usage domestique avec votre produit Sun.



Attention – votre produit Sun a été livré équipé d'un cordon d'alimentation à trois fils (avec prise de terre). Pour écarter tout risque d'électrocution, branchez toujours ce cordon dans une prise mise à la terre.

L'avertissement suivant s'applique uniquement aux systèmes équipés d'un interrupteur VEILLEUSE:



Attention – Le commutateur d'alimentation de ce produit fonctionne comme un dispositif de mise en veille uniquement. C'est la prise d'alimentation qui sert à mettre le produit hors tension. Veuillez donc à installer le produit à proximité d'une prise murale facilement accessible. Ne connectez pas la prise d'alimentation lorsque le châssis du système n'est plus alimenté.

Batterie au lithium



Attention – sur les cartes CPU Sun, une batterie au lithium (référence MK48T59Y, MK48TXXB-XX, MK48T18-XXXPCZ, M48T59W-XXXPCZ, ou MK48T08.) a été moulée dans l'horloge temps réel SGS. Les batteries ne sont pas des pièces remplaçables par le client. Elles risquent d'exploser en cas de mauvais traitement. Ne pas jeter la batterie au feu. Ne pas la démonter ni tenter de la recharger.

Bloc-batterie



Attention – Les unités Sun StorEdge 3900 and 6900 series contiennent une batterie étanche au plomb (produits énergétiques portatifs n°TLC02V50). Il existe un risque d'explosion si ce bloc-batterie est manipulé de façon erronée ou mal mis en place. Ne remplacez ce bloc que par un bloc-batterie Sun Microsystems du même type. Ne le démontez pas et n'essayez pas de le recharger hors du système. Ne faites pas brûler la batterie mais mettez-la au rebut conformément aux réglementations locales en vigueur.

Couvercle

Pour ajouter des cartes, de la mémoire, ou des unités de stockage internes, vous devrez démonter le couvercle de l'unité système Sun. Ne pas oublier de remettre ce couvercle en place avant de mettre le système sous tension.



Attention – il est dangereux de faire fonctionner un produit Sun sans le couvercle en place. Si l'on néglige cette précaution, on encourt des risques de blessures corporelles et de dégâts matériels.

Conformité aux certifications Laser

Les produits Sun qui font appel aux technologies lasers sont conformes aux normes de la classe 1 en la matière.

Class 1 Laser Product
Luokan 1 Laserlaite
Klasse 1 Laser Apparat
Laser Klasse 1

CD-ROM



Attention – L'utilisation de contrôles, de réglages ou de performances de procédures autre que celle spécifiée dans le présent document peut provoquer une exposition à des radiations dangereuses.

Normativas de seguridad

El siguiente texto incluye las medidas de seguridad que se deben seguir cuando se instale algún producto de Sun Microsystems.

Precauciones de seguridad

Para su protección observe las siguientes medidas de seguridad cuando manipule su equipo:

- Siga todas los avisos e instrucciones marcados en el equipo.
- Asegúrese de que el voltaje y la frecuencia de la red eléctrica concuerdan con las descritas en las etiquetas de especificaciones eléctricas del equipo.
- No introduzca nunca objetos de ningún tipo a través de los orificios del equipo. Pueden haber voltajes peligrosos. Los objetos extraños conductores de la electricidad pueden producir cortocircuitos que provoquen un incendio, descargas eléctricas o daños en el equipo.

Símbolos

En este libro aparecen los siguientes símbolos:



Precaución – Existe el riesgo de lesiones personales y daños al equipo. Siga las instrucciones.



Precaución – Superficie caliente. Evite el contacto. Las superficies están calientes y pueden causar daños personales si se tocan.



Precaución – Voltaje peligroso presente. Para reducir el riesgo de descarga y daños para la salud siga las instrucciones.

Precaución – Aplica la alimentación de CA al sistema.

Según el tipo de interruptor de encendido que su equipo tenga, es posible que se utilice uno de los siguientes símbolos:



Precaución – Elimina la alimentación de CA del sistema.



Precaución – El interruptor de Encendido/En espera se ha colocado en la posición de En espera.

Modificaciones en el equipo

No realice modificaciones de tipo mecánico o eléctrico en el equipo. Sun Microsystems no se hace responsable del cumplimiento de las normativas de seguridad en los equipos Sun modificados.

Ubicación de un producto Sun



Precaución – Para asegurar la fiabilidad de funcionamiento de su producto Sun y para protegerlo de sobrecalentamientos no deben obstruirse o taparse las rejillas del equipo. Los productos Sun nunca deben situarse cerca de radiadores o de fuentes de calor.



Precaución – De acuerdo con la norma DIN 45 635, Parte 1000, se admite un nivel de presión acústica para puestos de trabajo máximo de 70Db(A).

Cumplimiento de la normativa SELV

El estado de la seguridad de las conexiones de entrada/salida cumple los requisitos de la normativa SELV.

Conexión del cable de alimentación eléctrica



Precaución – Los productos Sun están diseñados para trabajar en una red eléctrica monofásica con toma de tierra. Para reducir el riesgo de descarga eléctrica, no conecte los productos Sun a otro tipo de sistema de alimentación eléctrica. Póngase en contacto con el responsable de mantenimiento o con un electricista cualificado si no está seguro del sistema de alimentación eléctrica del que se dispone en su edificio.



Precaución – No todos los cables de alimentación eléctrica tienen la misma capacidad. Los cables de tipo doméstico no están provistos de protecciones contra sobrecargas y por tanto no son apropiados para su uso con computadores. No utilice alargadores de tipo doméstico para conectar sus productos Sun.



Precaución – Con el producto Sun se proporciona un cable de alimentación con toma de tierra. Para reducir el riesgo de descargas eléctricas conéctelo siempre a un enchufe con toma de tierra.

La siguiente advertencia se aplica solamente a equipos con un interruptor de encendido que tenga una posición "En espera":



Precaución – El interruptor de encendido de este producto funciona exclusivamente como un dispositivo de puesta en espera. El enchufe de la fuente de alimentación está diseñado para ser el elemento primario de desconexión del equipo. El equipo debe instalarse cerca del enchufe de forma que este último pueda ser fácil y rápidamente accesible. No conecte el cable de alimentación cuando se ha retirado la fuente de alimentación del chasis del sistema.

Batería de litio



Precaución – En las placas de CPU Sun hay una batería de litio insertada en el reloj de tiempo real, tipo SGS Núm. MK48T59Y, MK48TXXB-XX, MK48T18-XXXPCZ, M48T59W-XXXPCZ, o MK48T08. Las baterías no son elementos reemplazables por el propio cliente. Pueden explotar si se manipulan de forma errónea. No arroje las baterías al fuego. No las abra o intente recargarlas.

Paquete de pilas



Precaución – Las unidades Sun StorEdge 3900 and 6900 series contienen una pila de plomo sellada, Productos de energía portátil nº TLC02V50. Existe riesgo de estallido si el paquete de pilas se maneja sin cuidado o se sustituye de manera indebida. Las pilas sólo deben sustituirse por el mismo tipo de paquete de pilas de Sun Microsystems. No las desmonte ni intente recargarlas fuera del sistema. No arroje las pilas al fuego. Deséchelas siguiendo el método indicado por las disposiciones vigentes.

Tapa de la unidad del sistema

Debe quitar la tapa del sistema cuando sea necesario añadir tarjetas, memoria o dispositivos de almacenamiento internos. Asegúrese de cerrar la tapa superior antes de volver a encender el equipo.



Precaución – Es peligroso hacer funcionar los productos Sun sin la tapa superior colocada. El hecho de no tener en cuenta esta precaución puede ocasionar daños personales o perjudicar el funcionamiento del equipo.

Aviso de cumplimiento con requisitos de láser

Los productos Sun que utilizan la tecnología de láser cumplen con los requisitos de láser de Clase 1.

Class 1 Laser Product
Luokan 1 Laserlaite
Klasse 1 Laser Apparat
Laser Klasse 1

CD-ROM



Precaución – El manejo de los controles, los ajustes o la ejecución de procedimientos distintos a los aquí especificados pueden exponer al usuario a radiaciones peligrosas.

GOST-R Certification Mark

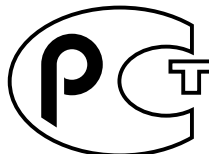

Nordic Lithium Battery Cautions

Norge



Caution – Litiumbatteri –
Ekspløsjonsfare. Ved utskifting benyttes kun batteri som anbefalt av apparatfabrikanten. Brukt batteri returneres apparatleverandøren.

Sverige



Caution – Explosionsfara vid felaktigt batteribyte. Använd samma batterityp eller en ekvivalent typ som rekommenderas av apparattillverkaren. Kassera använt batteri enligt fabrikantens instruktion.

Danmark



Caution – Litiumbatteri – Ekspløsjonsfare ved fejlagtig håndtering. Udsiftning må kun ske med batteri af samme fabrikat og type. Levér det brugte batteri tilbage til leverandøren.

Suomi



Caution – Paristo voi räjähtää, jos se on virheellisesti asennettu. Vaihda paristo ainoastaan laitevalmistajan suosittelemaan tyyppiin. Hävitä käytetty paristo valmistajan ohjeiden mukaisesti.

Contents

Preface xxiii

1. Introduction 1-1

- 1.1 Sun StorEdge 3900 Series Storage System 1-1
 - 1.1.1 Sun StorEdge 3910 Storage System 1-1
 - 1.1.2 Sun StorEdge 3960 Storage System 1-2
 - 1.1.3 Sun StorEdge 3900SL Storage System 1-2
- 1.2 Sun StorEdge 6900 Series Storage System 1-2
 - 1.2.1 Sun StorEdge 6910 Storage System 1-2
 - 1.2.2 Sun StorEdge 6910SL Storage System 1-2
 - 1.2.3 Sun StorEdge 6960 Storage System 1-3
 - 1.2.4 Sun StorEdge 6960SL Storage System 1-3

2. Installing the Storage Systems 2-1

- 2.1 Unpacking the Storage System 2-2
- 2.2 Moving and Placing the Storage System 2-3
- 2.3 Adjusting the Leveling Pads 2-4
- 2.4 Installing the Stabilizer Legs 2-5
- 2.5 Installing the Floor Mounting Brackets 2-7

3. Connecting a Second Storage System Cabinet 3-1

- 3.1 Connecting a Sun StorEdge 3900SL or 3960 Storage System Expansion Cabinet 3-2
 - 3.1.1 Connecting the Fibre Channel Cables 3-2
 - 3.1.2 Connecting the Ethernet Cable 3-4
- 3.2 Connecting Sun StorEdge 6960 or 6960SL Storage System Expansion Cabinet 3-6
 - 3.2.1 Connecting the Fibre Channel Cables 3-6
 - 3.2.2 Connecting the Ethernet Cable 3-8
- 4. Adding Power to the Storage System 4-1**
 - 4.1 Preparing the Storage System for Power 4-2
 - 4.2 Connecting the Power Cord 4-3
 - 4.3 Connecting the Grounding Strap 4-6
 - 4.4 Powering On the Storage System 4-7
 - 4.5 Troubleshooting the Installation 4-11
 - 4.6 The Next Step 4-11
 - 4.7 Powering Off the Storage System 4-12
 - 4.8 Reassembling the Storage System 4-13
- 5. Storage Service Processor Software Setup Instructions 5-1**
 - 5.1 Connecting to the Storage Service Processor From an Onsite System 5-2
 - 5.2 Connecting to the Storage Service Processor From a Remote System 5-3
 - 5.3 Setting the Host Name 5-4
 - 5.4 Setting the IP Address 5-7
 - 5.5 Setting the Date and Time Zone 5-8
 - 5.6 Verifying the Configuration 5-8
- 6. Power on the Sun StorEdge Remote Response Unit and Program 6-1**
- 7. Sun StorEdge 3900 and 6900 Series Setup Instructions 7-1**
 - 7.1 Sun StorEdge 3900 and 6900 Series Setup 7-1
 - 7.2 Configuring a Sun StorEdge 3900 Series Storage System 7-2

- 7.3 Setting up LUN Slicing and Masking on the Sun StorEdge 3900 Series 7-3
 - 7.3.1 Enabling Sun StorEdge T3+ Array Volume Slicing 7-3
 - 7.3.2 Creating Sun StorEdge T3+ Array LUN Slices 7-4
 - 7.3.3 Sun StorEdge T3+ Array LUN Masking 7-6
 - 7.3.4 Setting Sun StorEdge T3+ Array LUN Permissions on a Group or WWN 7-8
 - 7.3.5 Deleting a WWN from a Sun StorEdge T3+ Array Group 7-11
 - 7.3.6 Adding a WWN to a Sun StorEdge T3+ Array Group 7-14
 - 7.3.7 Removing a Sun StorEdge T3+ Array Group 7-15
 - 7.3.8 Displaying the Composite Map of a Sun StorEdge T3+ Array 7-17
 - 7.3.9 Next Step 7-23
- 7.4 Configuring the Sun StorEdge 3900SL or 3960 Storage System Cabinets into a Solution 7-23
- 7.5 Configuring a Sun StorEdge 6900 Series Storage System 7-26
- 7.6 Setting up Multiple Zones and VLUNs on the Sun StorEdge 6900 Series Storage System 7-28
 - 7.6.1 Creating Multiple Zones 7-29
 - 7.6.2 Creating Multiple VLUNs (With Zones and Without Zones) 7-32
 - 7.6.3 Next Step 7-37
- 7.7 Configuring the Sun StorEdge 6960 or 6960SL Storage System Cabinets into a Solution 7-37
- 8. Connecting the Storage System to the Host Overview 8-1**
 - 8.1 Connecting the Sun StorEdge 3910 and 6910 Storage Systems to the Host 8-1
 - 8.2 Connecting the Sun StorEdge 3960 or 6960 Storage Systems to the Host 8-4
 - 8.3 Connecting the Sun StorEdge 3900SL, 6910SL or 6960SL Storage Systems to the Host 8-7
 - 8.4 Attaching a Sun StorEdge 3900 or 6900 Series Storage Systems to a LAN 8-7
- 9. Connecting to Servers Running the Solaris Operating Environment 9-1**

- 9.1 Setting Up a Solaris Server 9-2
- 9.2 Configuring the `ssd.conf` File 9-5
- 9.3 Configuring the Sun StorEdge Traffic Manager 9-7
- 9.4 Matching the Host WWN to the Device Channel and Creating SLIC Zones for LUN Masking 9-8
 - 9.4.1 Setting up a SLIC Zone for Each HBA and Creating and Masking VLUNs 9-11
 - 9.4.2 Setting Up Newly Created VLUNs 9-18
- 9.5 Setting Up VERITAS Volume Manager Support 9-19
- 9.6 Mapping VLUNs to Devices 9-21
 - 9.6.1 Determining the Device Numbers for DMP 9-23
- 9.7 Setting Up Cascaded Switches on Sun StorEdge 6900 Series Storage System 9-23

- 10. Connecting to Servers Running the Microsoft Windows NT Operating Environment 10-1**
 - 10.1 Connecting a Sun StorEdge 3900 Series Storage System to a Microsoft Windows NT Server 10-2
 - 10.2 Connecting a Sun StorEdge 6900 Series Storage System to a Microsoft Windows NT Server 10-3
 - 10.3 Creating VLUNs on the Sun StorEdge 6900 Series Storage System for Microsoft Windows NT Server 10-5
 - 10.4 Setting Up Newly Created VLUNs 10-7

- 11. Connecting to Servers Running the Microsoft Windows 2000 Operating Environment 11-1**
 - 11.1 Connecting a Sun StorEdge 3900 Series Storage System to a Microsoft Windows 2000 Server 11-2
 - 11.2 Connecting a Sun StorEdge 6900 Series Storage System to a Microsoft Windows 2000 Server 11-2
 - 11.3 Creating VLUNs on the Sun StorEdge 6900 Series Storage System for Microsoft Windows 2000 11-5
 - 11.4 Setting Up Newly Created VLUNs 11-7

12. Connecting to Servers Running the Red Hat Linux 7.2 Operating Environment 12-1

- 12.1 Connecting a Sun StorEdge 3900 Series Storage System to a Red Hat Linux Server 12-2
- 12.2 Connecting a Sun StorEdge 6900 Series Storage System to a Red Hat Linux Server 12-3
- 12.3 Creating VLUNs on the Sun StorEdge 6900 Series Storage System for a Red Hat Linux Server 12-5
- 12.4 Setting Up Newly Created VLUNs 12-7

A. Product Specifications A-1

- A.1 Physical Characteristics A-1
- A.2 Physical Specifications A-2
- A.3 Clearance and Service Access A-3
- A.4 Power Sequencer Electrical Specifications A-4
- A.5 Environmental Requirements A-4

Index 1

Figures

- FIGURE 2-1 Leveling Pad 2-4
- FIGURE 2-2 Stabilizer Legs 2-5
- FIGURE 2-3 Installing the Right Stabilizer Leg 2-6
- FIGURE 2-4 Adjusting the Leveling Pads on the Stabilizer Leg 2-6
- FIGURE 2-5 Removing the Mounting Screws 2-8
- FIGURE 2-6 Attaching the Floor-mounting Brackets 2-9
- FIGURE 3-1 Sun StorEdge 3960 Expansion Cabinet Cabling 3-3
- FIGURE 3-2 Sun StorEdge 3960 Storage System Cabling 3-5
- FIGURE 3-3 Sun StorEdge 6960 Expansion Cabinet Cabling 3-7
- FIGURE 3-4 Sun StorEdge 6960 Storage System Cabling 3-9
- FIGURE 4-1 Location of Key Switch on Bottom Front Panel 4-2
- FIGURE 4-2 Power Sequencer Control Panel 4-3
- FIGURE 4-3 Connecting the Power Cord 4-5
- FIGURE 4-4 Connecting the Grounding Strap to the Front Power Sequencer 4-7
- FIGURE 4-5 Location of Key Switch on Bottom Front Panel 4-8
- FIGURE 4-6 AC Power Sequencer Control Panel 4-9
- FIGURE 4-7 Front Sequencer Status Lights 4-10
- FIGURE 5-1 Connecting the Service Cable to a Server 5-2
- FIGURE 8-1 Sun StorEdge 3910 Storage System Cabling 8-2
- FIGURE 8-2 Sun StorEdge 6910 Storage System Cabling 8-3

FIGURE 8-3 Sun StorEdge 3960 Storage System Cabling 8-5

FIGURE 8-4 Sun StorEdge 6960 Storage System Cabling 8-6

Tables

TABLE 3-1	Connecting Cables to the Second Cabinet—FRU List	3-1
TABLE 3-2	Sun StorEdge 3960 Storage System Expansion Cabinet Connections	3-4
TABLE 3-3	Sun StorEdge 6960 Storage System Expansion Cabinet Connections	3-8
TABLE 4-1	Power Cord—FRU List	4-2
TABLE 4-2	Voltage Requirements for Maximum Operating Voltage and Frequency Ranges	4-4
TABLE 4-3	Current Requirements at Nominal Line Voltage for a Storage System in Maximum Configuration	4-4
TABLE 5-1	Service Processor Setup—FRU List	5-2
TABLE 9-1	ssd-config-list Property Parameter	9-6
TABLE 9-2	<i>data-property-name Node Specification Parameters</i>	9-6

Preface

The *Sun StorEdge™ 3900 and 6900 Series 1.1 Installation Guide* provides procedures for installing the Sun StorEdge™ 3900 and 6900 series storage systems. Because the Sun StorEdge 3900 and 6900 series storage systems are shipped as complete configurations, this guide describes the initial setup of the storage system, including the power on and off procedures, and the procedures to connect the storage system to the host. Only a qualified service provider should perform the tasks in this guide.

Caution – You must read the *Sun StorEdge 3900 and 6900 Series Regulatory and Safety Compliance Manual* or the “Safety Agency Compliance Statements” on page iii” before beginning any procedure in this guide.

How This Guide is Organized

Chapter 1 contains an introduction and an overview of the guide.

Chapter 2 describes the steps to install the Sun StorEdge 3900 and 6900 series storage systems.

Chapter 3 describes how to cable the power cord and connect the ground strap and add a second to the Sun StorEdge 3900SL, 3960, 6960, and 6960SL storage systems.

Chapter 4 describes how to power the storage systems on and off.

Chapter 5 describes the steps to setup the Storage Service Processor software.

Chapter 6 describes how to power on and configure the Sun StorEdge Remote response unit.

Chapter 7 describes how to configure the storage systems and how to set up the second cabinet to a Sun StorEdge 3900SL, 3960, 6960, and 6960SL storage systems.

Chapter 8 describes an overview of connecting the storage systems to the host server.

Chapter 9 describes connecting the storage system to a server running the Solaris™ operating environment.

Chapter 10 describes connecting the storage system to a server running Microsoft Windows NT operating environment.

Chapter 11 describes connecting the storage system to a server running Microsoft Windows 2000 operating environment.

Chapter 12 describes connecting the storage system to a server running the Red Hat Linux operating environment.

Appendix A contains the physical specifications of the storage systems.

Using UNIX Commands

This document does not contain information about basic UNIX® commands and procedures such as shutting down the subsystem, booting the subsystem, and configuring devices.

See one or more of the following for this information:

- *Solaris Handbook for Sun Peripherals*
- AnswerBook2™ online documentation for the Solaris™ software environment
- Other software documentation that you received

Typographic Conventions

Typeface	Meaning	Examples
AaBbCc123	The names of commands, files, and directories; on-screen computer output	Edit your <code>.login</code> file. Use <code>ls -a</code> to list all files. % You have mail.
AaBbCc123	What you type, when contrasted with on-screen computer output	% su Password:
<i>AaBbCc123</i>	Book titles, new words or terms, words to be emphasized	Read Chapter 6 in the <i>User's Guide</i> . These are called <i>class</i> options. You <i>must</i> be superuser to do this.
	Command-line variable; replace with a real name or value	To delete a file, type <code>rm filename</code> .

Shell Prompts

Shell	Prompt
C shell	<i>machine_name</i> %
C shell superuser	<i>machine_name</i> #
Bourne shell and Korn shell	\$
Bourne shell and Korn shell superuser	#

Related Documentation

The following is a list of documents related to the Sun StorEdge 3900 or 6900 series storage system. For any document number with *nn* as a suffix, use the most current document.

Product	Title	Part Number
Late-breaking News	<ul style="list-style-type: none">• <i>Sun StorEdge 3900 and 6900 Series 1.1 Release Notes</i>	816-3247
Sun StorEdge 3900 and 6900 series hardware information	<ul style="list-style-type: none">• <i>Sun StorEdge 3900 and 6900 Series 1.1 Site Preparation Guide</i>	816-5256-10
	<ul style="list-style-type: none">• <i>Sun StorEdge 3900 and 6900 Series 1.1 Regulatory and Safety Compliance Manual</i>	816-5257-10
	<ul style="list-style-type: none">• <i>Sun StorEdge 3900 and 6900 Series 1.1 Reference and Service Manual</i>	816-5253-10
Sun StorEdge T3 and T3+ array	<ul style="list-style-type: none">• <i>Sun StorEdge T3 and T3+ Array Start Here</i>	816-0772- <i>nn</i>
	<ul style="list-style-type: none">• <i>Sun StorEdge T3 and T3+ Array Installation, Operation, and Service Manual</i>	816-0773- <i>nn</i>
	<ul style="list-style-type: none">• <i>Sun StorEdge T3 and T3+ Array Administrator's Guide</i>	816-0776- <i>nn</i>
	<ul style="list-style-type: none">• <i>Sun StorEdge T3 and T3+ Array Configuration Guide</i>	816-0777- <i>nn</i>
	<ul style="list-style-type: none">• <i>Sun StorEdge T3 and T3+ Array Site Preparation Guide</i>	816-0778- <i>nn</i>
	<ul style="list-style-type: none">• <i>Sun StorEdge T3 and T3+ Field Service Manual</i>	816-0779- <i>nn</i>
Diagnostics	<ul style="list-style-type: none">• <i>Sun StorEdge T3 and T3+ Array Release Notes</i>	816-0781- <i>nn</i>
	<ul style="list-style-type: none">• <i>Storage Automated Diagnostics Environment User's Guide</i>	816-3142-10
Sun StorEdge network FC switch-8 and switch-16	<ul style="list-style-type: none">• <i>Sun StorEdge Network FC Switch-8 and Switch-16 Release Notes</i>	816-0842-10
	<ul style="list-style-type: none">• <i>Sun StorEdge Network FC Switch-8 and Switch-16 Installation and Configuration Guide</i>	816-0830-12
	<ul style="list-style-type: none">• <i>Sun StorEdge Network FC Switch-8 and Switch-16 Best Practices Manual</i>	816-2688-10
	<ul style="list-style-type: none">• <i>Sun StorEdge Network FC Switch-8 and Switch-16 Operations Guide</i>	816-1986-10
	<ul style="list-style-type: none">• <i>Sun StorEdge Network FC Switch-8 and Switch-16 Field Troubleshooting Guide</i>	816-0252-10
SANbox™ switch management using SANsurfer®	<ul style="list-style-type: none">• <i>SANbox-8/16 Segmented Loop Switch Management User's Manual</i>	875-3060-10
	<ul style="list-style-type: none">• <i>SANbox-8 Segmented Loop Fibre Channel Switch Installer's/ User's Manual</i>	875-1881-11
	<ul style="list-style-type: none">• <i>SANbox-16 Segmented Loop Fibre Channel Switch Installer's/ User's Manual</i>	875-3059-10
Expansion cabinet	<ul style="list-style-type: none">• <i>Sun StorEdge Expansion Cabinet Installation and Service Manual</i>	805-3067-12

Product	Title	Part Number
Storage service processor	• <i>Sun V100 Server User's guide</i>	806-5980-10
	• <i>Netra X1 Server User's Guide</i>	806-5980-10
	• <i>Netra X1 Server Hard Disk Drive Installation Guide</i>	806-7670-10
Solaris	• <i>Solaris Handbook for Sun Peripherals</i>	816-4468-10
	• <i>Solaris 8 System Administration Collection</i>	
Red Hat Linux 7.2	• <i>High Availability for Sun StorEdge Products Version RC1 in the Red Hat Linux Operating Environment</i>	816-5309-10
Configuration	• <i>Sun StorEdge Traffic Manager Software Installation and Configuration Guide</i>	816-1420-10
Failover Drivers	• <i>Sun Multipath Failover Driver 1.0 for Windows NT User's Guide</i>	806-7766-10

Accessing Sun Documentation Online

You can view, print, or purchase a broad selection of Sun documentation, including localized versions, at:

<http://www.sun.com/documentation>

Sun Welcomes Your Comments

Sun is interested in improving its documentation and welcomes your comments and suggestions. You can email your comments to Sun at:

docfeedback@sun.com

Please include the part number (816-5252-10) of this document in the subject line of your email.

Introduction

The Sun StorEdge 3900 and 6900 series storage systems are complete preconfigured storage solutions. The Sun StorEdge 3900 series storage systems provide three different configurations for the direct attach storage (DAS) environment. The Sun StorEdge 6900 series storage systems has four configurations for the storage area network (SAN) environment.

A description of the software associated with the Sun StorEdge 3900 and 6900 series storage systems is given in the *Sun StorEdge 3900 and 6900 Series 1.1 Reference and Service Manual*.

This chapter contains the following sections:

- “Sun StorEdge 3900 Series Storage System” on page 1
- “Sun StorEdge 6900 Series Storage System” on page 2

1.1 Sun StorEdge 3900 Series Storage System

The Sun StorEdge 3900 series storage system provides three different configurations for the direct attach storage (DAS) environment.

1.1.1 Sun StorEdge 3910 Storage System

The Sun StorEdge 3910 storage system uses two Sun StorEdge Network FC Switch-8 switches as the host interface. The Sun StorEdge 3910 storage system can support up to four Sun StorEdge T3+ array partner groups.

1.1.2 Sun StorEdge 3960 Storage System

The Sun StorEdge 3960 storage system uses two Sun StorEdge Network FC Switch-16 switches as the host interface and can support up to four Sun StorEdge T3+ array partner groups in one cabinet. By adding a second Sun StorEdge Expansion Cabinet, the Sun StorEdge 3960 storage system supports up to nine Sun StorEdge T3+ array partner groups.

1.1.3 Sun StorEdge 3900SL Storage System

The Sun StorEdge 3900SL storage system uses switches that are supplied by the customer for host connectivity. However, these external switches are not allowed to connect to the Sun StorEdge 3900SL storage system internal local area network (LAN).

1.2 Sun StorEdge 6900 Series Storage System

The Sun StorEdge 6900 series storage system has four configurations that can be used in the storage area network (SAN) environment.

1.2.1 Sun StorEdge 6910 Storage System

The Sun StorEdge 6910 storage system uses two Sun StorEdge FC Switch-8 switches as the host interface and can support up to three Sun StorEdge T3+ array partner groups.

1.2.2 Sun StorEdge 6910SL Storage System

The Sun StorEdge 6910SL storage system uses switches that are supplied by the customer for host connectivity. However, these external switches are not allowed to connect to the Sun StorEdge 6910SL storage system internal local area network (LAN).

1.2.3 Sun StorEdge 6960 Storage System

The Sun StorEdge 6960 storage system uses two Sun StorEdge FC Switch-16 switches as the host interface and can support up to three Sun StorEdge T3+ array partner groups in one cabinet. By adding a second Sun StorEdge Expansion Cabinet, the Sun StorEdge 6960 storage system supports up to eight Sun StorEdge T3+ array partner groups.

1.2.4 Sun StorEdge 6960SL Storage System

The Sun StorEdge 6960SL storage system uses switches that are supplied by the customer for host connectivity. However, these external switches are not allowed to connect to the Sun StorEdge 6960SL storage system internal local area network (LAN).

Installing the Storage Systems

This chapter describes how to unpack and install the Sun StorEdge 3900 and 6900 series storage systems.

The storage system is shipped completely configured including the following items described in this chapter:

- Two power sequencer assemblies
- Four floor-mounting brackets
- Two stabilizer legs

The floor-mounting brackets enable you to bolt the storage system to the floor. If you are not installing the floor mounting brackets, you should install the stabilizer legs. The stabilizer legs are extended to prevent the storage system from tipping over when field-replaceable units (FRUs) are installed, removed, or serviced.

Note – If you are installing a Sun StorEdge 3900SL, 3960, 6960, or 6960SL storage system with a second cabinet, perform the procedures in this chapter for both cabinets.

This chapter contains the following sections:

- Section 2.1 “Unpacking the Storage System” on page 2-2
- Section 2.2 “Moving and Placing the Storage System” on page 2-3
- Section 2.3 “Adjusting the Leveling Pads” on page 2-4
- Section 2.4 “Installing the Stabilizer Legs” on page 2-5
- Section 2.5 “Installing the Floor Mounting Brackets” on page 2-7

The following tools are required to perform the tasks in this chapter:

- Leveling wrench (shipped with the storage system)
- 7/16-inch wrench

2.1 Unpacking the Storage System

If the storage system is already unpacked, proceed to Section 2.2 “Moving and Placing the Storage System” on page 2-3.

1. Inspect all shipping containers for evidence of physical damage.

If a shipping carton is damaged, request that the carrier’s agent be present when the carton is opened. Keep all of the contents and packing material for the agent’s inspection.



Caution – Use three or more people to unpack and set up the storage system. The shipping weight of the unit varies, depending on the number of FRUs that are shipped with the unit. A typical Sun StorEdge 3910, 6910, or 6910SL storage system can weigh up to 1465 pounds (547 kilograms). A typical Sun StorEdge 3900SL, 3960, 6960, or 6960SL storage system with two cabinets can weigh up to 2895 pounds (1660 kilograms).

2. Unpack the storage system.

Refer to the unpacking instructions printed on the shipping carton.

Note – The stabilizer legs, floor-mounting brackets, and associated hardware are packed in the side pockets of the packing material that encase the storage system. Do not dispose of the unused hardware, you may need it later.

3. Verify that the items you received match the shipping list.

4. Reassemble the packing materials and save them for future use.

To prepare the storage system for shipment or storage, follow (in reverse order) the unpacking instructions attached to or printed on the panels of each shipping container.

If you cannot store the shipping materials, recycle or dispose of the materials properly. Your local recycling authority can supply specific information.

2.2 Moving and Placing the Storage System

See Section A.3 “Clearance and Service Access” on page A-3 for the space necessary around the storage system.

The ground strap for the storage system is 6.5 feet (2 meters) long. Consider this distance when you are placing the storage system. (The procedure for connecting the ground strap is covered in detail in Section 4.3 “Connecting the Grounding Strap” on page 4-6.)

Refer to the specifications in Appendix A when you are determining where to place the storage system.



Caution – Never move storage systems when system power is on. Excessive movement can cause catastrophic disk drive failure. Always power the storage system off and if necessary, disconnect it before moving it.



Caution – Never lift the storage system by the cosmetic panel surfaces or pull by the back door. Use three or more people to move the storage system safely. Two people must restrain the front of the storage system to control the movement. One person should be behind the storage system. To prevent the storage system from tipping as you move it, push or pull only on the middle section of the storage system.

Note – You *must* do either Section 2.3 “Adjusting the Leveling Pads” on page 2-4 and Section 2.4 “Installing the Stabilizer Legs” on page 2-5 or Section 2.5 “Installing the Floor Mounting Brackets” on page 2-7 to stabilize the storage system.

2.3 Adjusting the Leveling Pads

If you want to attach the storage system to the floor, skip to Section 2.5 “Installing the Floor Mounting Brackets” on page 2-7.

Leveling pads (screws) are located at each corner of the base of the storage system (FIGURE 2-1).



Caution – If you are not using the four floor mounting brackets, the four leveling pads mounted on the bottom plate of the rack must be lowered to the floor for the storage system to meet Underwriters Laboratories’ physical stability requirements.

1. **Open the rear door.**
2. **Remove the leveling wrench by unlocking the plastic strap that holds it to the inside of the frame, near the top of the storage system.**
Do not cut the strap. Press the plastic tab to unlock the strap around the wrench, and then slide part of the strap through the lock to loosen the wrench.
3. **Adjust the four leveling pads on the storage system frame using the leveling wrench.**

The four pads should press against the floor so that the storage system does not move or rock in any direction.

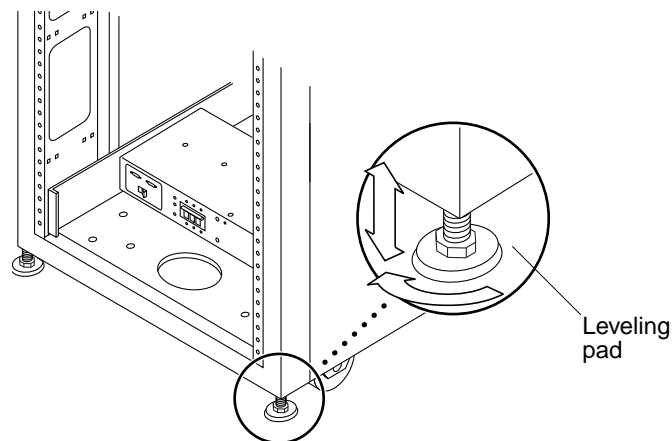

FIGURE 2-1 Leveling Pad

2.4 Installing the Stabilizer Legs

If you want to attach the storage system to the floor, skip to Section 2.5 “Installing the Floor Mounting Brackets” on page 2-7.

The stabilizer legs help prevent the storage system from tipping over when FRUs are taken out of the storage system. The stabilizer legs must be properly installed and set to be effective.



Caution – Always extend the stabilizer legs before you attempt to install new FRUs or service FRUs in the storage system.

1. Loosen the securing screw on the right stabilizer leg (FIGURE 2-2).

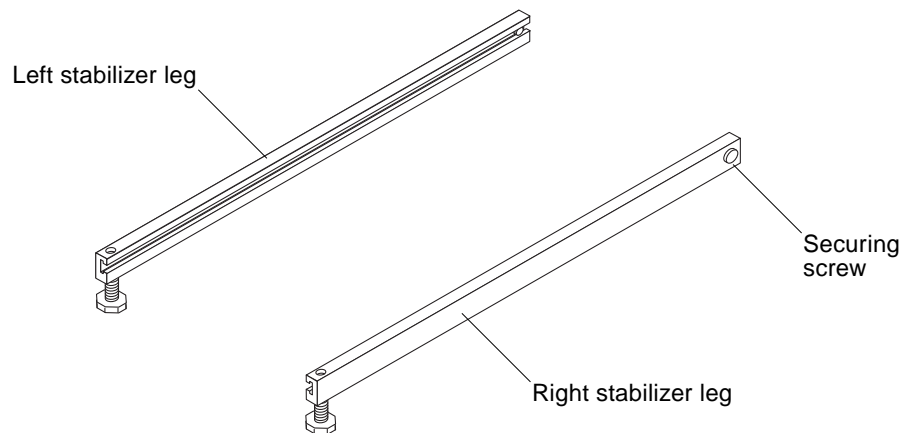

FIGURE 2-2 Stabilizer Legs

2. Slide the right stabilizer leg over the three mounting screws at the bottom of the storage system (FIGURE 2-3).

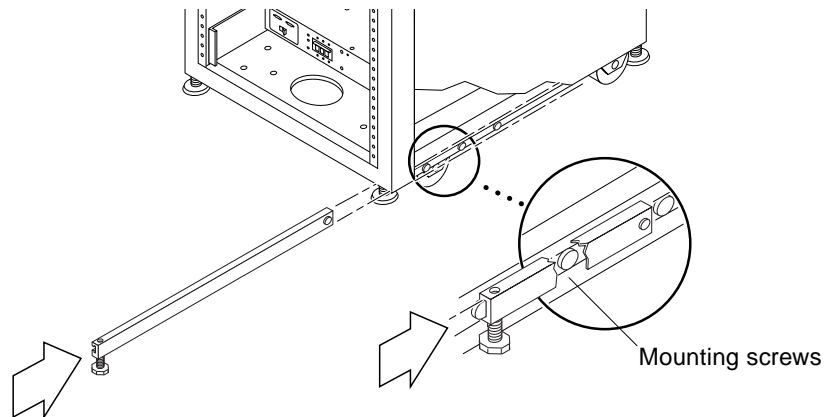

FIGURE 2-3 Installing the Right Stabilizer Leg

3. Fully extend the right stabilizer leg.
4. Tighten the securing screw.
This prevents the stabilizer leg from falling off the mounting screws when it is extended.
5. Repeat Step 1 through Step 3 for the left stabilizer leg.
6. Use the leveling wrench to adjust the feet on both stabilizer legs so that they touch the floor (FIGURE 2-4).

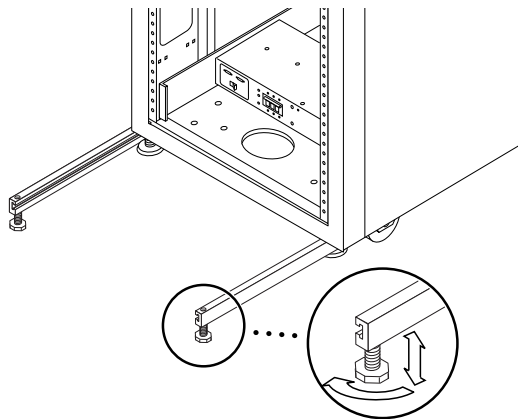

FIGURE 2-4 Adjusting the Leveling Pads on the Stabilizer Leg

7. Slide both stabilizer legs under the storage system.
8. Secure the leveling wrench inside the storage system.
9. Close the door.
10. If you are installing a Sun StorEdge 3900SL, 3960, 6960 or 6960SL storage system with the second cabinet to be installed, proceed to Chapter 3 otherwise proceed to Chapter 4.

2.5 Installing the Floor Mounting Brackets

Skip this section if you have installed the stabilizer legs and adjusted the leveling pads in Section 2.3 “Adjusting the Leveling Pads” on page 2-4 and Section 2.4 “Installing the Stabilizer Legs” on page 2-5.

Use the four floor-mounting brackets in place of the stabilizer legs if you want to attach the storage system to the floor.



Caution – Do not bolt the floor mounting brackets to the deck plating of a raised (computer-room) floor because this would result in an unstable mount.

Note – If you are installing the floor-mounting brackets over previously installed threaded rods, you should loosely install the floor-mounting brackets to the rods and then to the storage system.

1. Remove the three mounting screws on the bottom right of the storage system (FIGURE 2-5).

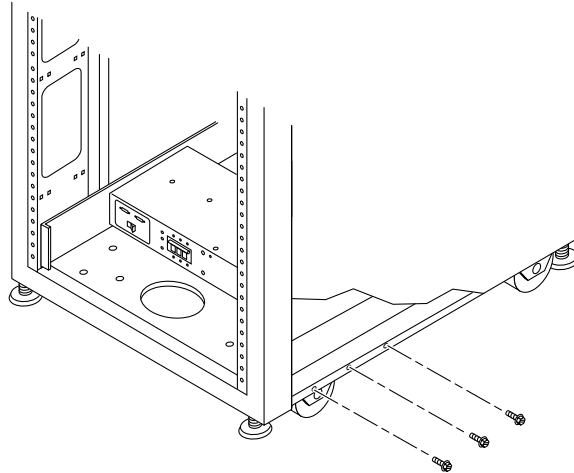

FIGURE 2-5 Removing the Mounting Screws

2. Using a 7/16-inch wrench, attach the right floor-mounting brackets to the front and back of the storage system (FIGURE 2-6).

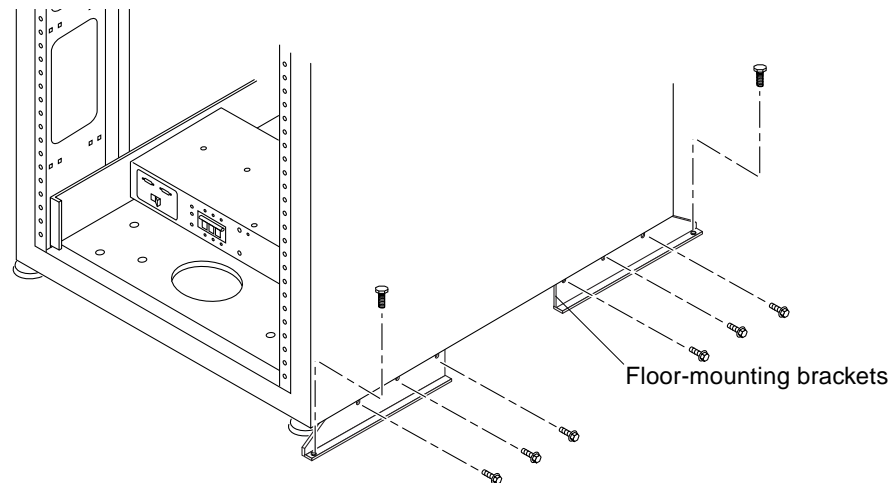

FIGURE 2-6 Attaching the Floor-mounting Brackets

3. Bolt the right floor-mounting brackets to the floor.
The bolts to secure the floor-mounting brackets to the floor are not included.
4. Repeat Step 1 through Step 3 for the left floor-mounting brackets.

Connecting a Second Storage System Cabinet

If you have a Sun StorEdge, 3900SL, 3960, 6960, or 6960SL storage system that has a second cabinet to be installed, perform the steps in this chapter. Otherwise, skip this chapter and go to Chapter 4 to power up the system.

Note – You cannot upgrade a Sun StorEdge 3910 storage system to a dual-cabinet Sun StorEdge 3900SL or 3960 storage system. Also, you cannot upgrade a Sun StorEdge 6910 or 6910SL storage system to a dual-cabinet Sun StorEdge 6960 or 6960SL storage system. You must purchase a Sun StorEdge 3900SL, 3960, 6960 or 6960SL storage system single cabinet and purchase the second cabinet when needed.

This chapter contains the following sections:

- Section 3.1, “Connecting a Sun StorEdge 3900SL or 3960 Storage System Expansion Cabinet” on page 3-2
- Section 3.2, “Connecting Sun StorEdge 6960 or 6960SL Storage System Expansion Cabinet” on page 3-6

The FRUs in TABLE 3-1 are required to perform the tasks in this chapter:

TABLE 3-1 Connecting Cables to the Second Cabinet—FRU List

FRU Description	Part Number	Quantity
ASSY, CABL, FIBOP, LC-SC, 15 meter Fibre Channel cable	537-1034-01	1
Power cord for 72 in. (185 cm) Sun StorEdge Expansion Cabinet (US), L6-30P	595-4881	2
Power cord for 72 in. (185 cm) StorEdge Expansion Cabinet (International), IEC 309	595-4882	2
78.74 in. (2-meter) ground strap (in the kit shipped with the storage system)	530-1619-01	1

The following tools are required to perform the tasks in this chapter:

- Laptop or server terminal
- Leveling wrench (shipped with the storage system)
- 7/16-inch wrench

3.1 Connecting a Sun StorEdge 3900SL or 3960 Storage System Expansion Cabinet

If you purchased a Sun StorEdge 3900SL or 3960 storage system with the expansion cabinet, the following instructions describe how to connect the expansion cabinet.

Note – If you purchased a Sun StorEdge 3900SL storage system with the expansion cabinet, the connections between the Sun StorEdge T3+ array partner pairs and the switches are determined by the switches that are supplied by the customer.

3.1.1 Connecting the Fibre Channel Cables

In the Sun StorEdge 3960 storage system, the Sun StorEdge network Fibre Channel switch-16 (hereafter referred to as the *16-port Fibre Channel switch*) connect to the host through the Fibre Channel I/O ports on the switches.

In a Sun StorEdge 3960 storage system that has the expansion cabinet installed, the expansion cabinet must have one of each of the Sun StorEdge T3+ array partner pairs cabled in to one of the 16-port Fibre channel switches. The Fibre Channel cable is attached to however many Sun StorEdge T3+ arrays that are installed in the expansion cabinet. The other ends of the cable are labeled to show which Sun StorEdge T3+ array the cable originates from. For example, the Fibre Channel cable will be labeled:

- t3be0(m), which denotes that the cable originates from the bottom master of the t3be0 pair of Sun StorEdge T3+ arrays
- t3be0(a), which denotes that the cable originates from the alternate master in the top Sun StorEdge T3+ array of the t3be0 pair of Sun StorEdge T3+ arrays.

FIGURE 3-1 shows the cable connections from a fully configured Sun StorEdge 3960 storage system to switches sw1a and sw1b. TABLE 3-2 shows the cable designation and the port to which it should be connected.

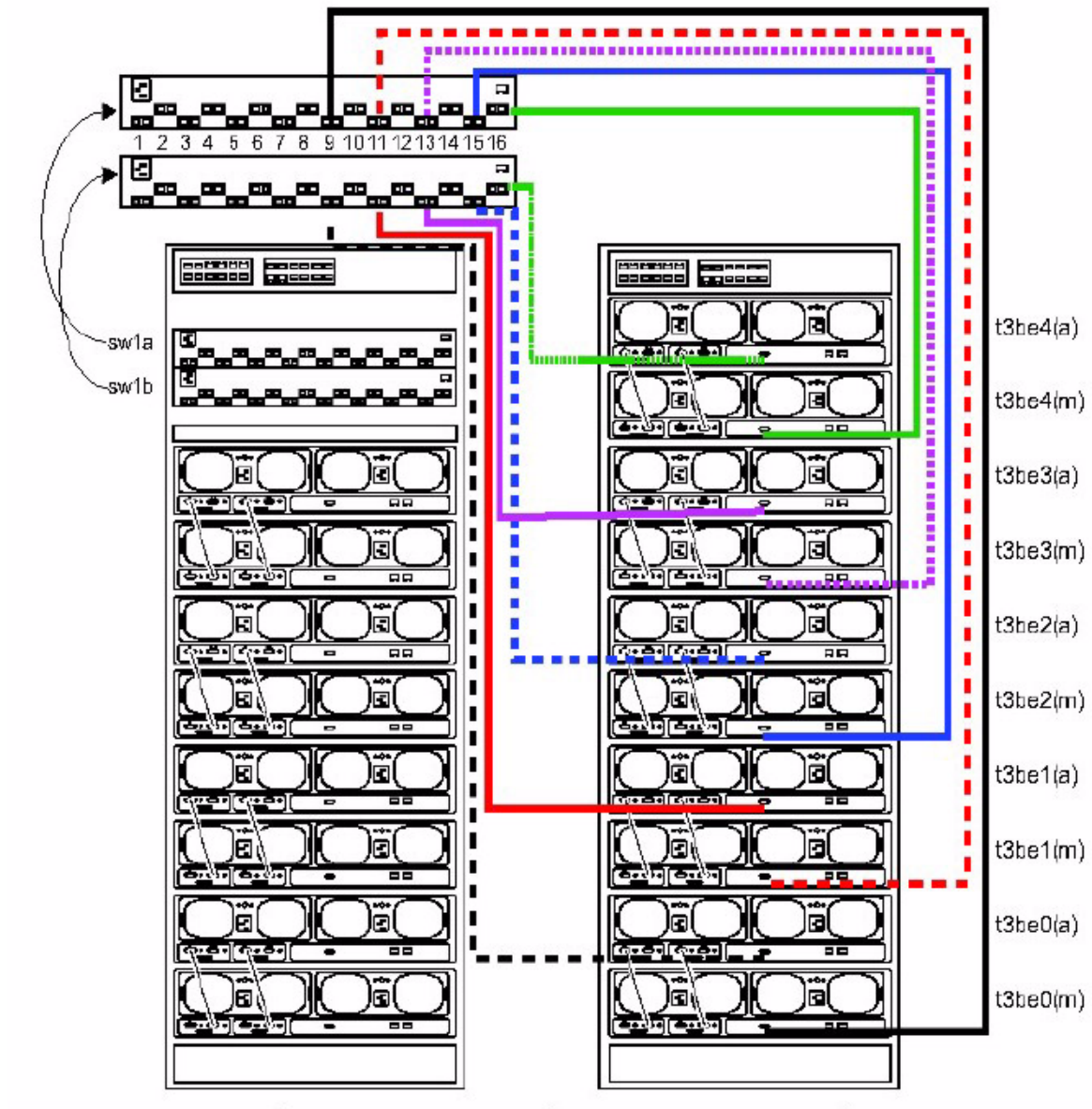

FIGURE 3-1 Sun StorEdge 3960 Expansion Cabinet Cabling

TABLE 3-2 Sun StorEdge 3960 Storage System Expansion Cabinet Connections

Cable Label	Switch and Switch Connection
t3be4(a)	sw1b (P16)
t3be4(m)	sw1a (P16)
t3be3(a)	sw1b (P13)
t3be3(m)	sw1a (P13)
t3be2(a)	sw1b (P15)
t3be2(m)	sw1a (P15)
t3be1(a)	sw1b (P11)
t3be1(m)	sw1a (P11)
t3be0(a)	sw1b (P9)
t3be0(m)	sw1a (P9)

3.1.2 Connecting the Ethernet Cable

In a two-cabinet configuration, the Ethernet hubs in both cabinets must be interconnected. The 10-meter, shielded, Ethernet crossover cable connects into either port 12 or 24 of the hub in the base cabinet. The MDI switch on the hub in the base cabinet is set to the *In* position. The other end of the 10-meter, shielded, Ethernet crossover cable connects into either port 12 or 24 of the Ethernet hub in the expansion cabinet. The MDI switch is set to the *In* position on that hub as well.

See FIGURE 3-2 for the diagram of this cabling.

3.2 Connecting Sun StorEdge 6960 or 6960SL Storage System Expansion Cabinet

If you purchased a Sun StorEdge 6960 or 6960SL storage system with the expansion cabinet, the following instructions describe how to connect the expansion cabinet.

Note – If you purchased a Sun StorEdge 6960SL storage system with the expansion cabinet, the connections between the Sun StorEdge T3+ array partner pairs and the switches are determined by the switches that are supplied by the customer.

3.2.1 Connecting the Fibre Channel Cables

In a Sun StorEdge 6960 storage system that has the expansion cabinet installed, the expansion cabinet must have one of each of the Sun StorEdge T3+ array partner pairs cabled in to one of the Sun StorEdge network Fibre Channel switch-16 switches (hereafter referred to as the *16-port Fibre Channel switch*). The Fibre Channel cable is attached to however many Sun StorEdge T3+ arrays that are installed in the expansion cabinet. The other ends of the cable are labeled to show which Sun StorEdge T3+ array from which the cable originates. For example, the Fibre Channel cable will be labeled:

- t3be0(m), which denotes that the cable originates from the bottom master Sun StorEdge T3+ array of the t3be0 pair of Sun StorEdge T3+ arrays
- t3be0(a), which denotes that the cable originates from the alternate master on the top Sun StorEdge T3+ array of the t3be0 pair of Sun StorEdge T3+ arrays.

FIGURE 3-3 shows the cable connections from a fully configured Sun StorEdge 6960 storage system in to switches sw2a and sw2b. TABLE 3-3 shows the cable designations and the port to which it should be connected.

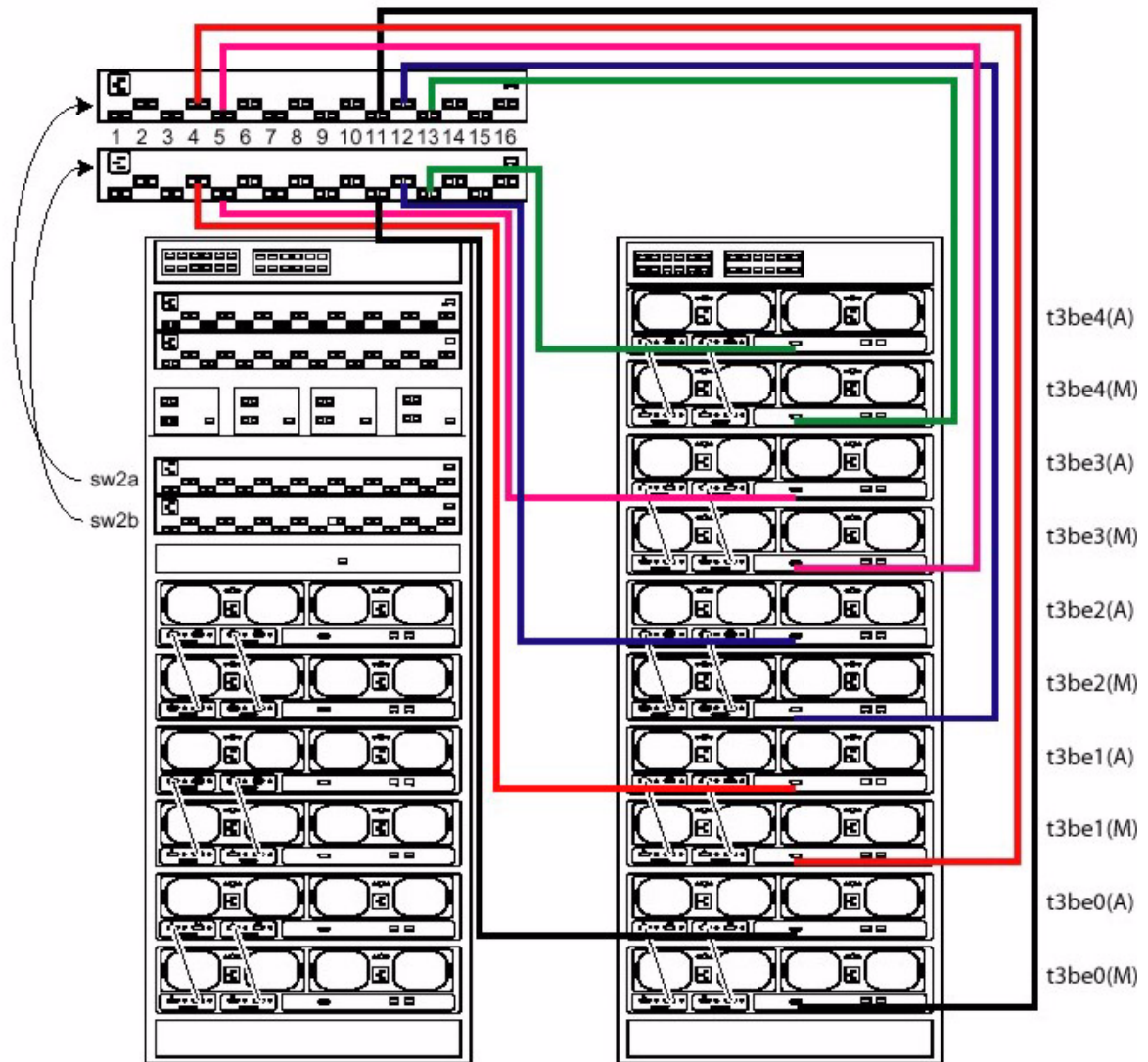

FIGURE 3-3 Sun StorEdge 6960 Expansion Cabinet Cabling

TABLE 3-3 Sun StorEdge 6960 Storage System Expansion Cabinet Connections

Cable Label	Switch and Switch Connections
t3be4(a)	sw2b (P13)
t3be4(m)	sw2a (P13)
t3be3(a)	sw2b (P5)
t3be3(m)	sw2a (P5)
t3be2(a)	sw2b (P12)
t3be2(m)	sw2a (P12)
t3be1(a)	sw2b (P4)
t3be1(m)	sw2a (P4)
t3b30(a)	sw2b (P11)
t3be0(m)	sw2a (P11)

3.2.2 Connecting the Ethernet Cable

In a two-cabinet configuration, the Ethernet hubs in both cabinets must be interconnected. The 10-meter, shielded, Ethernet crossover cable connects to either port 12 or 24 of the hub in the base cabinet. The MDI switch on the hub in the base cabinet is set to the *In* position. The other end of the 10-meter, shielded, Ethernet crossover cable connects to either port 12 or 24 of the Ethernet hub in the expansion cabinet. The MDI switch is set to the *In* position on that hub as well.

See FIGURE 3-4 for diagrams of this cabling.

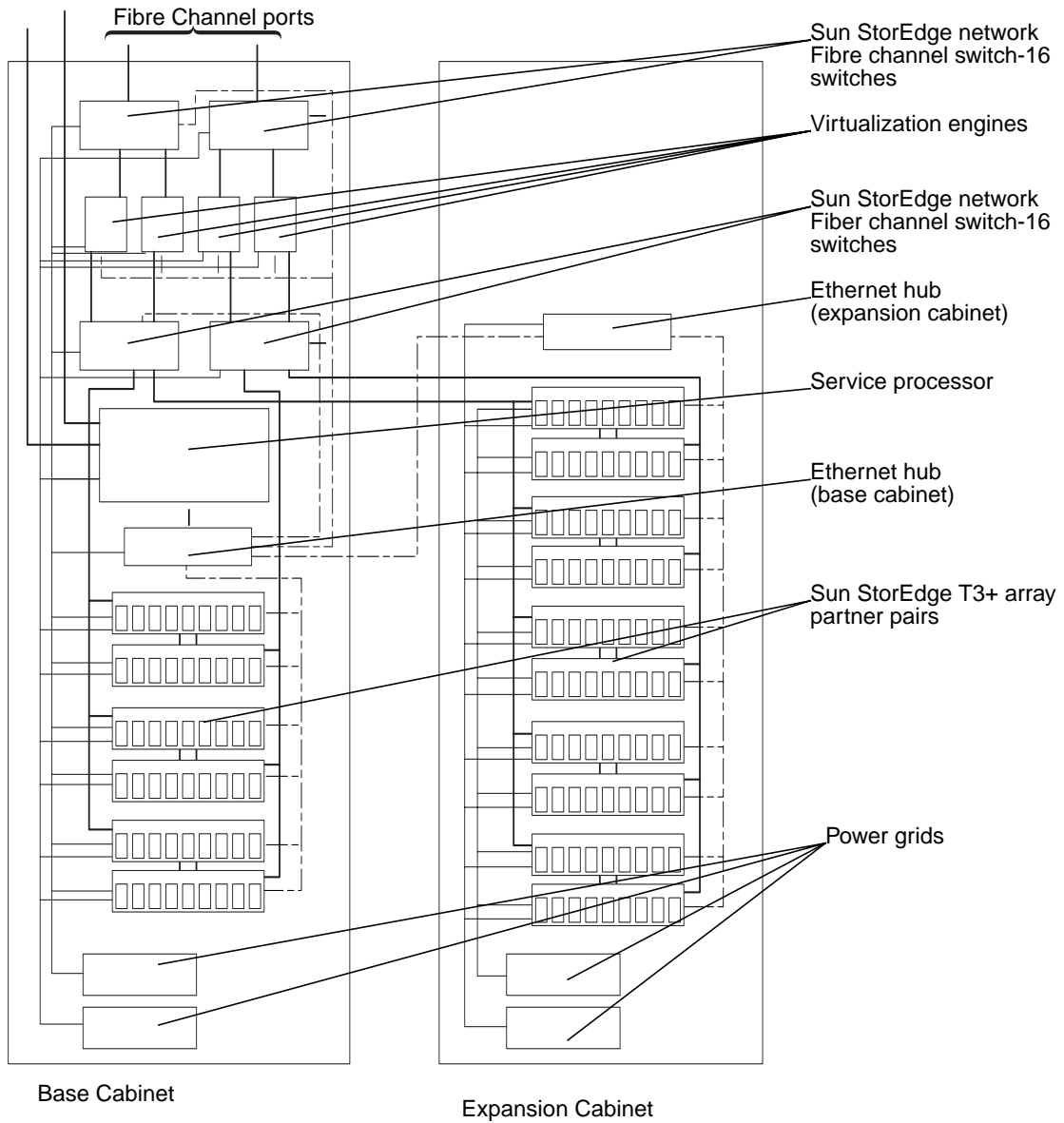

FIGURE 3-4 Sun StorEdge 6960 Storage System Cabling

Adding Power to the Storage System

This chapter describes:

- Connecting the power cord to the storage system power sequencer
- Connecting the ground strap from the storage system to the server and other cabinets
- Connecting the storage system to the host

Note – If you are installing a Sun StorEdge 3900SL, 3960, 6960, or 6960SL storage system with a second (expansion) cabinet, perform the procedures in this chapter for both cabinets.

This chapter contains the following sections:

- Section 4.1 “Preparing the Storage System for Power” on page 4-2
- Section 4.2 “Connecting the Power Cord” on page 4-3
- Section 4.3 “Connecting the Grounding Strap” on page 4-6
- Section 4.4 “Powering On the Storage System” on page 4-7
- Section 4.5 “Troubleshooting the Installation” on page 4-11
- Section 4.6 “The Next Step” on page 4-11
- Section 4.7 “Powering Off the Storage System” on page 4-12
- Section 4.8 “Reassembling the Storage System” on page 4-13

The FRUs in TABLE 4-1 are required to perform the tasks in this chapter:

TABLE 4-1 Power Cord—FRU List

FRU Description	Part Number	Quantity
Power cord for 72 in. (185 cm) Sun StorEdge Expansion Cabinet (US), L6-30P	595-4881	2
Power cord for 72 in. (185 cm) StorEdge Expansion Cabinet (International), IEC 309	595-4882	2
78.74 in. (2-meter) ground strap (in the kit shipped with the storage system)	530-1619-01	1

The following tools are required to perform the tasks in this chapter:

- Keys for key switch (in the kit shipped with the storage system)
- Slotted screwdriver, 1/4 inch
- Voltmeter

4.1 Preparing the Storage System for Power

1. Verify that the key switch located at the bottom front of the storage system is in the Standby position (FIGURE 4-1).

Keys for this switch are packed in the kit that was shipped with your storage system. If the key switch is not in the standby position, insert the key and turn the key switch to standby.

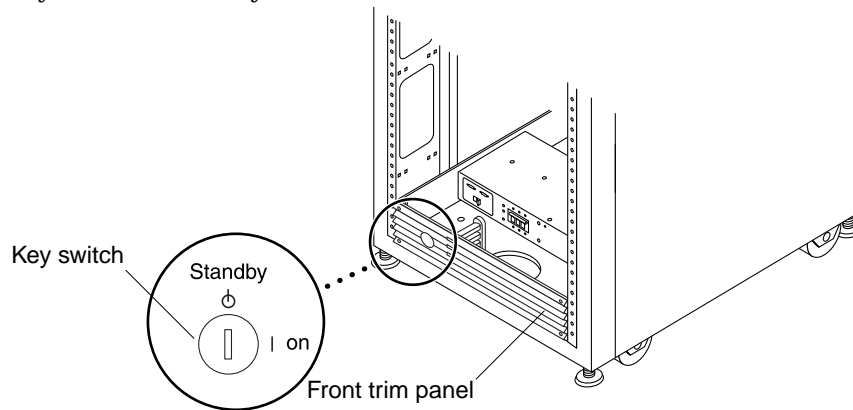

FIGURE 4-1 Location of Key Switch on Bottom Front Panel

2. Open the front door.
3. Loosen the four screws on the front trim panel and remove the panel.
Set the panels aside.
4. Open the back door of the storage system.

4.2 Connecting the Power Cord



Caution – The storage system is designed to work with single-phase power systems that have a grounded neutral conductor. To reduce the risk of electric shock, do not connect the storage system into any other type of power system.

1. Verify that each AC power sequencer circuit breaker is in the Off position and that the Local/Remote switch is in the Local position (FIGURE 4-2).

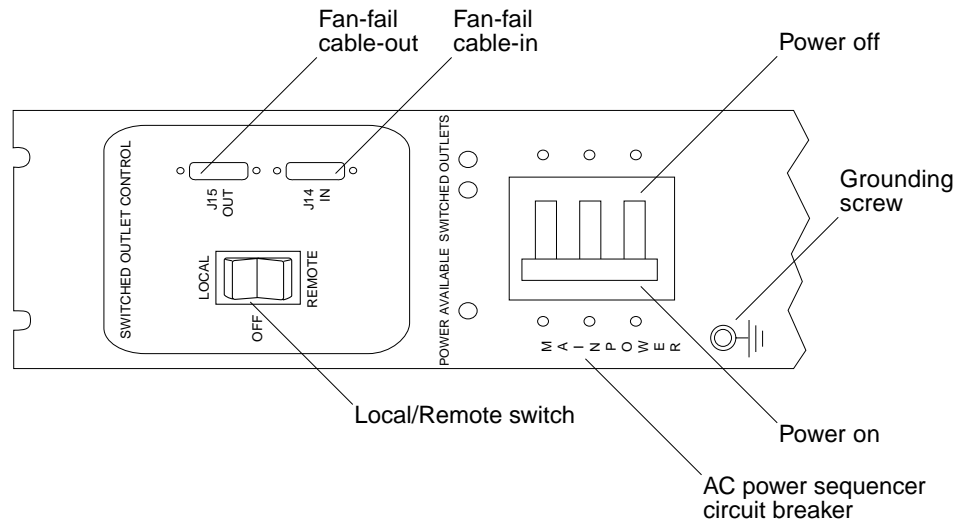

FIGURE 4-2 Power Sequencer Control Panel

2. Verify that the stated rating matches the AC input voltage to the system (TABLE 4-2 and TABLE 4-3).

Check the electrical ratings label on the serial number label attached to the power sequencer.

TABLE 4-2 Voltage Requirements for Maximum Operating Voltage and Frequency Ranges

Voltage and Frequency Range	Requirement
AC voltage rating	200 to 240 VAC
AC voltage range	180 to 264 VAC
Frequency range	47 to 63 Hz

TABLE 4-3 Current Requirements at Nominal Line Voltage for a Storage System in Maximum Configuration

Nominal and Maximum Voltage and Current	Requirement
Nominal AC input voltage rating single phase	200 to 240 VAC
Maximum current requirement	24A at 240 VAC
Maximum current per power sequencer outlet	32A

3. Connect the square female end of a power cord to the rear power sequencer connector (FIGURE 4-3).

Flip open the cover latch to access the connectors.

Route the power cord directly through the opening in the storage system base.

4. Pull the latch cover over the power cord to secure it to the power socket.

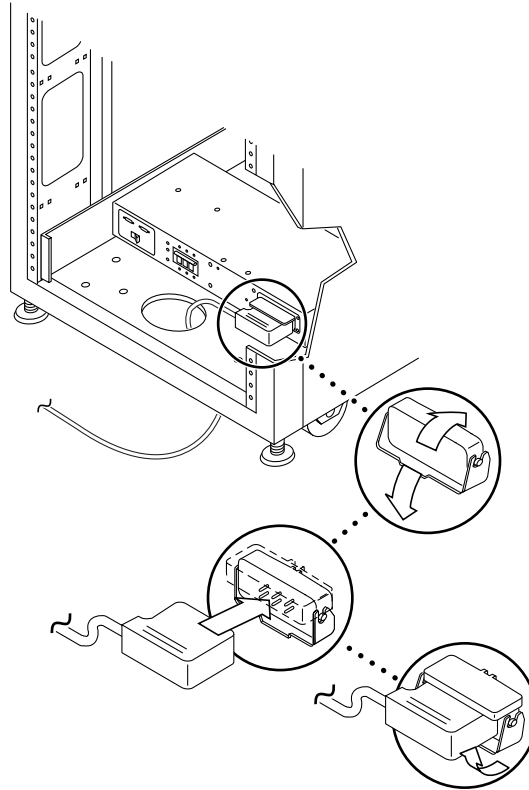

FIGURE 4-3 Connecting the Power Cord

5. Connect the other end of the power cords to a grounded outlet.

The following connector types are provided on the power cord:

- NEMA L6-30P for 200—240 V North American operation
- 32A, single-phase, IEC 309 connector for 220—240 V international operation



Caution – There is a risk of electric shock. Do NOT apply AC power to the unit yet.

Caution – The storage system has a high leakage current to ground. Strictly observe all Caution and Note statements to reduce the risk of electric shock.

Note – If the appropriate mating receptacle is not available, you can remove the connector from the cord. The cord can then be permanently connected to a dedicated branch circuit by a qualified electrician. Check local electrical codes for proper installation requirements.

6. Repeat Step 3 through Step 5 for the other power sequencer.

4.3 Connecting the Grounding Strap

The grounding conductor must be connected to either of the following:

- Earth at service equipment
- Supply transformer or motor-generator set (if supplied by a separately derived system)

The outlets in the vicinity of the unit must be of the grounding type, and the grounding conductors for these outlets must be connected to earth ground.

- 1. Locate the 78.74-inch (2-meter) grounding strap from the kit that was shipped with your storage system.**
- 2. Screw one end of the grounding strap to the power sequencer on the system cabinet or on a cabinet that is grounded nearest to the storage system (FIGURE 4-4 on page 4-7).**

3. Screw the other end of the grounding strap to the front power sequencer in the storage system (FIGURE 4-4).

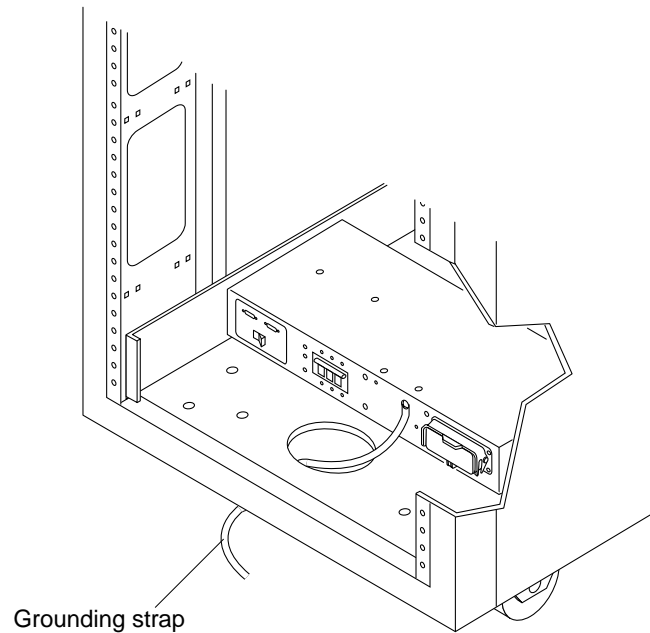

FIGURE 4-4 Connecting the Grounding Strap to the Front Power Sequencer

Note – If you are installing a storage system with an expansion cabinet, do not connect the grounding strap from the expansion cabinet to the base cabinet—use a different grounding point for the expansion cabinet.

4.4 Powering On the Storage System

Note – If you are powering on a Sun StorEdge 3900SL, 3960, 6960, or 6960SL storage system with the expansion cabinet attached, perform the power-on sequence for both cabinets.



Caution – To avoid damage to internal circuits, do not connect or disconnect any cable while the FRU associated with the cable is powered on.

1. **Open the front door.**
2. **Remove the trim panels and set aside.**
3. **Verify that the key switch located at the bottom front of the storage system is in the Standby position (FIGURE 4-5).**

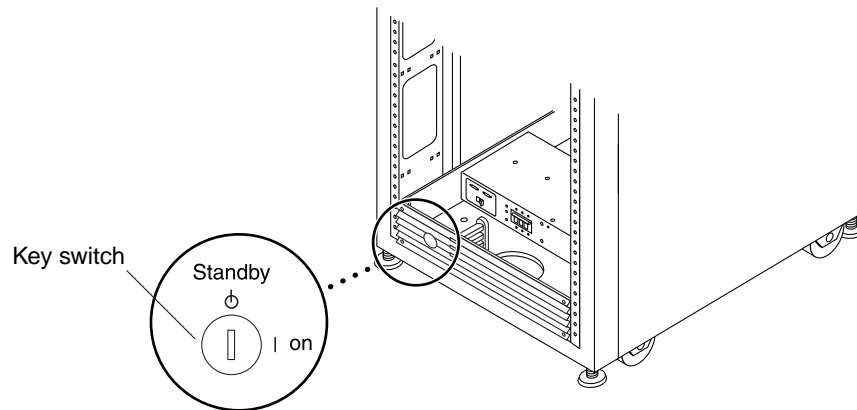

FIGURE 4-5 Location of Key Switch on Bottom Front Panel

4. **Push the AC power sequencer circuit breakers at the bottom front and bottom back of the storage system to Off (FIGURE 4-6).**

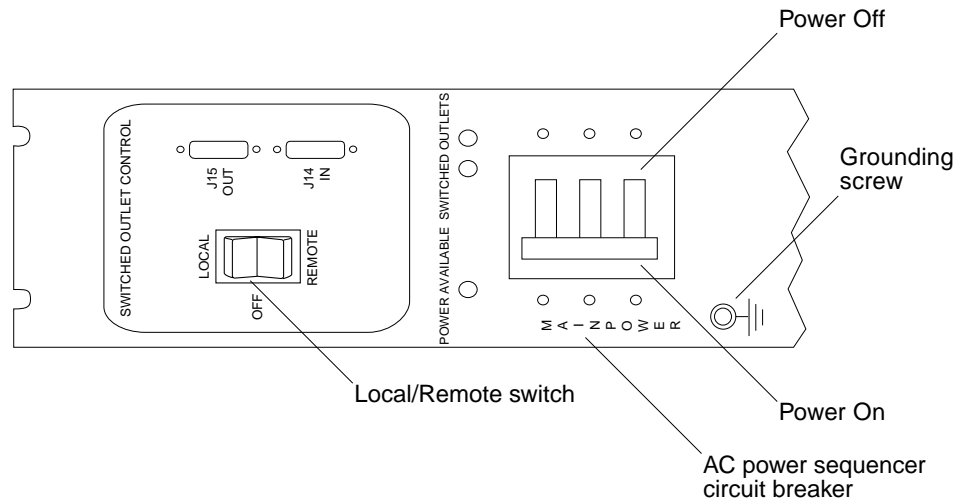

FIGURE 4-6 AC Power Sequencer Control Panel

5. Verify that the AC power cord of the storage system is connected to the correct AC outlet.



Caution – Do not disconnect the AC power cord from the outlet when you work on or in the storage system. This connection provides a ground path that prevents damage from electrostatic discharge.



Caution – Never move storage systems when system power is on. Excessive movement can cause catastrophic disk drive failure. Always power the storage system off before moving it.

6. Push the Local/Remote switch at the bottom front and bottom back of the storage system to Remote (FIGURE 4-6).
7. Press the AC power sequencer circuit breakers at the bottom front and bottom back of the storage system to On (FIGURE 4-6).
8. Turn the key switch at the front of the storage system to the On position (FIGURE 4-7).

The cabinet will power on approximately 20 seconds after you turn the key switch to On. This delay minimizes power surges.

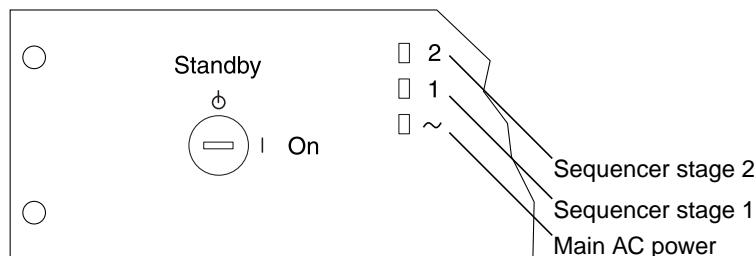

FIGURE 4-7 Front Sequencer Status Lights

The three power status indicators on the front panel show the status of the front power sequencer. The main AC power light emitting diode (LED) lights when power is applied to the storage system. The LED for sequencer stage 1 lights next, followed by the LED for sequencer stage 2.

Note – The bottom LED lights only when the AC power sequencer circuit breakers for the front power supply are on.

Note – To check the status of the back power sequencer, open the back door of the storage system and look for the three green LEDs on the back power sequencer.

9. All components of the Sun StorEdge 3900 and 6900 Series storage system will power up in an optimal state.

If the batteries in the Sun StorEdge T3+ arrays need to be charged, the Sun StorEdge T3+ arrays will go through a charge cycle. This is indicated by the blinking green LED on the right side of every power plug on the Sun StorEdge T3+ arrays.

During the time the batteries are charging, the Sun StorEdge T3+ arrays cache is turned off and will automatically enable itself when the batteries reach a full charge.

10. Verify that all the components have only green LEDs turned on.

11. Replace the trim panels over the power sequencers.

12. Bring the host system(s) back online if necessary.

If you have quiesced the host systems, you might have to enter a specific software command to bring the host system online so that the host system will recognize the storage system.

See the software documentation for your host system for more information.

You might need to edit the configuration file for your components. See the *Sun StorEdge 3900 and 6900 Series 1.1 Reference and Service Manual* for a description of the base configuration for a component and how to modify the base configuration. Also see the *Solaris Handbook for Sun Peripherals* for software instructions.

4.5 Troubleshooting the Installation

Use this list as a guide for isolating common installation problems.

1. Verify that all power and data cables are properly installed and in the right location.
2. Verify that all Fibre Channel connections, cable adapters, and GBICs are installed and secure.
3. Verify that the power is turned on to the storage system.

See the *Sun StorEdge 3900 and 6900 Series 1.1 Reference and Service Manual*, *Storage Automated Diagnostic Environment User's Guide*, and *Sun StorEdge 3900 and 6900 Series Troubleshooting Guide* for a description of the procedures to perform fault detection and isolation.

4.6 The Next Step

If you are not going to power off the storage system at this time, see Section 4.8 “Reassembling the Storage System” on page 4-13.

4.7 Powering Off the Storage System

Before you power off the storage system, you must halt any I/O between the host system(s) and the storage system.

Depending upon the type of host system(s) and the software running on the host system(s), you might need to:

- Stop software from accessing the storage system
- Exit the operating environment
- Quiesce the host system(s)

Refer to the following documents for specific instructions:

- *Solaris Handbook for Sun Peripherals*
- System administration guides that correspond to your operating system
- Documentation that came with your host system(s)



Caution – Failure to stop I/O between host system(s) and the storage system can result in the loss of data.

Note – If you are powering off a Sun StorEdge 3900SL, 3960, 6960, or 6960SL storage system with the second cabinet attached, perform the power-off sequence for both cabinets.

Follow these steps to power off the Sun StorEdge 3900 and 6900 Series storage systems:

1. **Open the front door.**
2. **Turn the key switch located at the front of the storage system(s) to the Standby position (FIGURE 4-5).**
3. **At the bottom of the storage system(s), remove the trim panels and push the AC power sequencer circuit breakers to Off (FIGURE 4-6).**



Caution – If you want to stop all AC power input to the storage system, you must disconnect the power cables to both power sequencers.

4. **If you are servicing FRUs other than Sun StorEdge T3+ arrays (for example, the power sequencer), disconnect the storage system(s) power cords from the grounded outlets.**



Caution – If you want to stop all AC power input to the storage system, you must disconnect the power cables to both power sequencers.

4.8 Reassembling the Storage System

1. Replace the trim panels.

Tighten the four screws to secure the front and back trim panels to the storage system.

Note – If you are routing cables under the floor, route the cables between the bottom panel and the kick panel.

2. Close all open doors.

Storage Service Processor Software Setup Instructions

In this chapter are step-by-step instructions for setting up the software on the Storage Service Processor in the Sun StorEdge 3900 and 6900 series storage systems. All Storage Service Processors are configured in the factory as a master Storage Service Processor (MSSP), which gives them the primary role of aggregating multiple Storage Service Processors into one administrative point as well as controlling the alerts and forwarding them to the designated service providers.

If you only have one Sun StorEdge 3900 or 6900 series storage system, it is not necessary to make any changes to the hostname or IP address.

The IP addressing of the aggregation of Storage Service Processors is dictated by the `/etc/inet/hosts` file. The default setting in that file for all Storage Service Processors that Sun ships with the IP address are set to `10.0.0.10` and the name `msp0`.

This chapter is organized as follows:

- Section 5.1, “Connecting to the Storage Service Processor From an Onsite System” on page 5-2
- Section 5.2, “Connecting to the Storage Service Processor From a Remote System” on page 5-3
- Section 5.3, “Setting the Host Name” on page 5-4
- Section 5.4, “Setting the IP Address” on page 5-7
- Section 5.5, “Setting the Date and Time Zone” on page 5-8
- Section 5.6, “Verifying the Configuration” on page 5-8

The FRUs in TABLE 5-1 are required to perform the tasks in this chapter:

TABLE 5-1 Service Processor Setup—FRU List

FRU Description	Part Number
DB9F cable (standard adapter cable, shipped with the Storage Service Processor)	530-3100-01
DB25 cable (standard adapter cable, shipped with the Storage Service Processor)	530-2889-03
Service cable	530-2093-01
Network cable	530-1871-04

The following tools are required to perform the tasks in this chapter:

- Laptop computer or server terminal

5.1 Connecting to the Storage Service Processor From an Onsite System

1. Connect one end of the service cable onto the serial console port of the service panel.

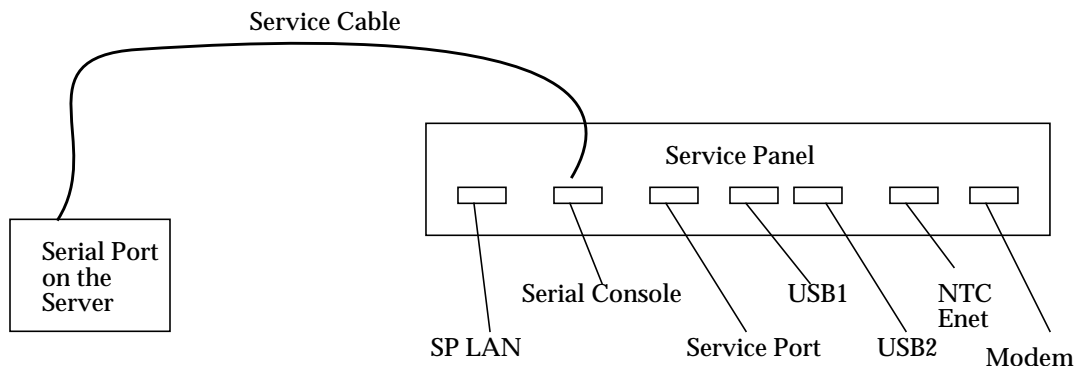

FIGURE 5-1 Connecting the Service Cable to a Server

2. Connect the other end to an available serial port on your onsite system.

Note – The DB9 and DB25 adapters, shipped with each unit, are used to make this connection.

3. From the onsite system, establish a connection to the Storage Service Processor.

The commands used to make the connection will vary depending on the onsite system. For example, from a Solaris server you could type:

```
# tip -9600 /dev/ttyX
Connected
```

After the connection is made, press Return. Expect the prompt:

```
mSP0 console login:
```

See Section 5.3, “Setting the Host Name” on page 5-4 to continue with Storage Service Processor setup instructions.

5.2 Connecting to the Storage Service Processor From a Remote System

1. Establish a remote connection to the site through the Sun StorEdge Remote Response modem.

Note – No remote service capabilities are available if the site has not purchased the Sun StorEdge Remote Response optional software.

2. Connect one end of the service cable to the service port of the service panel on the Sun StorEdge 3900 or 6900 series storage system that is connected to the modem.

3. Connect the other end of the service cable to the serial console port of the service panel on the Sun StorEdge 3900 or 6900 series storage system that is to be remotely configured.

4. Log into the Storage Service Processor that is attached to the modem and make a `tip(1)` connection to `/dev/ttyb`.

```
# tip -9600 /dev/ttyb
Connected
```

After the connection is made, press Return. Expect the prompt:

```
msp0 console login:
```

See Section 5.3, “Setting the Host Name” on page 5-4 to continue with Storage Service Processor setup instructions.

5.3 Setting the Host Name

Setting the host name of a Storage Service Processor is necessary in only two situations:

- You have purchased multiple cabinets to be installed in the same geographical vicinity with no requirements for administrative access.
- You require that the Storage Service Processors be part of your management LAN and accessible through your infrastructure. In order to do this, consider these two items:

- Which naming service is being used for your intranet infrastructure

The Storage Service Processor boots the Solaris 8 operating environment, so it is important that you have the necessary expertise to manage the network. You must also be knowledgeable about using the `sys-unconfig(1M)` utility. Additional information is available from the Solaris administration guides.

- Whether or not you are using the Sun StorEdge Remote Response software

If the installation is to take advantage of the Sun StorEdge Remote Response service and maintain your access to the tools required to manage the storage solution, the balance between remote access and security is a consideration.

1. Make a connection to the Storage Service Processor.

- If you have the Sun StorEdge Remote Response option installed, refer to Section 5.2, “Connecting to the Storage Service Processor From a Remote System” on page 5-3 for instructions.

- If you are connecting from a system that is at the same location, refer to Section 5.1, “Connecting to the Storage Service Processor From an Onsite System” on page 5-2 for instructions.

2. Log into the Storage Service Processor and make a `tip(1)` connection to `/dev/ttyb`.

```
# tip -9600 /dev/ttyb
```

After the connection is made, press Return. Expect the prompt:

```
msp0 console login:
```

3. Log in as root.

```
msp0 console login: root  
Password: password
```

4. If necessary, change the host name entry in each of the following files:

■ /etc/inet/hosts

```
# Internet host table

127.0.0.1 localhost
#
10.0.0.10 msp0.localdomain      msp0  loghost #Master Service Processor

10.0.0.3  ntc0                  # Network Terminal Concentrator
10.0.0.11 ssp1.localdomain ssp1 # Slave Service Processor
10.0.0.12 ssp2.localdomain ssp2 # Slave Service Processor
10.0.0.13 ssp3.localdomain ssp3 # Slave Service Processor
#
192.168.0.1  sp0                # dmfe1 Ethernet Port
#
192.168.0.20 v1a                # Vicom Virtual Engine
192.168.0.21 v1b                # Vicom Virtual Engine
192.168.0.22 v2a                # Vicom Virtual Engine
192.168.0.23 v2b                # Vicom Virtual Engine
#
192.168.0.30 sw1a                # SAN FC Switch (8 / 16 port)
192.168.0.31 sw1b                # SAN FC Switch (8 / 16 port)
192.168.0.32 sw2a                # SAN FC Switch (8 / 16 port)
192.168.0.33 sw2b                # SAN FC Switch (8 / 16 port)
#
192.168.0.40 t3b0                # T3+
192.168.0.41 t3b1                # T3+
192.168.0.42 t3b2                # T3+
192.168.0.43 t3b3                # T3+
#
192.168.0.50 t3be0                # T3+ (Expansion)
192.168.0.51 t3be1                # T3+ (Expansion)
192.168.0.52 t3be2                # T3+ (Expansion)
192.168.0.53 t3be3                # T3+ (Expansion)
192.168.0.54 t3be4                # T3+ (Expansion)
```

Note – The /etc/inet/hosts file entry for your host name must include the IP address of your host and the word loghost at the end of the line.

■ /etc/nodename

```
ssp1
```

- /etc/hostname.dmfe0

```
ssp1
```

- /etc/net/ticlts/hosts

```
#ident "@(#)hosts 1.2 92/07/14 SMI" /* SVr4.0 1.2 */  
# RPC Hosts  
ssp1.localdomain ssp1.localdomain
```

- /etc/net/ticots/hosts

```
#ident "@(#)hosts 1.2 92/07/14 SMI" /* SVr4.0 1.2 */  
# RPC Hosts  
ssp1.localdomain ssp1.localdomain
```

- /etc/net/ticotsord/hosts

```
#ident "@(#)hosts 1.2 92/07/14 SMI" /* SVr4.0 1.2 */  
# RPC Hosts  
ssp1.localdomain ssp1.localdomain
```

5. Reboot the Storage Service Processor. For example:

```
# /usr/sbin/reboot
```

5.4 Setting the IP Address

1. Make a connection to the Storage Service Processor.

- If you have the Sun StorEdge Remote Response option installed, refer to “Connecting to the Storage Service Processor From a Remote System” on page 5-3 for instructions.
- If you are connecting from a system that is at the same location, refer to “Connecting to the Storage Service Processor From an Onsite System” on page 5-2 for instructions.

2. Change the `/etc/inet/hosts` file so that the Storage Service Processor entry reflects the correct IP address. See the `hosts(4)` man page for details.

5.5 Setting the Date and Time Zone

The date and time zone are initially set during the Solaris installation. You can change the date by using the `date(1)` command and change the time zone by editing the `/etc/TIMEZONE` file, which sets the `TZ` variable. See the `TIMEZONE(4)` man page for details.

5.6 Verifying the Configuration

When the Storage Service Processor reboots, verify the changes.

- The console login prompt should reflect the proper name for the Storage Service Processor. For example:

```
ssp1 Console Login:
```

- Use the `ifconfig(1M)` command to verify the IP address information. For example:

```
ssp1: root# /usr/sbin/ifconfig -a
lo0: flags=1000849<UP,LOOPBACK,RUNNING,MULTICAST,IPv4> mtu 8232 index 1
    inet 127.0.0.1 netmask ff000000
dmfe0: flags=1000843<UP,BROADCAST,RUNNING,MULTICAST,IPv4> mtu 1500 index 2
    inet 10.0.0.11 netmask ff000000 broadcast 10.255.255.255
    ether 1:2:34:56:7:89
dmfel: flags=1000843<UP,BROADCAST,RUNNING,MULTICAST,IPv4> mtu 1500 index 3
    inet 192.168.0.1 netmask ffffffff broadcast 192.168.0.255
    ether 1:2:34:56:7:89
ssp1: root#
```

- Use the `uname(1)` command to verify the name associated with the Storage Service Processor. For example:

```
ssp1: root# /bin/uname -n  
ssp1
```

- Plug the network cable connection into the Storage Service Processor LAN port on the front of the Service Panel and test the network by entering the following:

```
ssp1: root# ping msp0  
msp0 is alive
```

Power on the Sun StorEdge Remote Response Unit and Program

This procedure is performed after storage system is powered on if the Sun StorEdge Remote Response unit is an option selected by the customer.

The Storage Service Processor communicates on two networks. The internal Component Local Area Network (LAN) (Network Address 192.168.0.0) and the Storage Service Processor (SP) LAN (Network Address 10.0.0.0). The SP LAN aggregates multiple Storage Service Processors and the Network Terminal Concentrator .

There may be cases where the LAN addresses have been changed to accommodate special circumstances. In these cases, you need to determine some preliminary information about the Storage Service Processor and the network it resides on before the Network Terminal Concentrator can be set up. The following information is needed:

- Internet Protocol (IP) address of the Storage Service Processor
- Netmask of the network
- Broadcast of the network
- IP address that will be used to set up the Network Terminal Concentrator

Most of this information can be obtained by issuing an `ifconfig -a` command on the Storage Service Processor. See Chapter 5 for the procedures to log onto the Storage Service Processor. The interface information that is *not* the `lo0` FRU is the information required. CODE EXAMPLE 6-1 shows the output from the `ifconfig -a` command.

CODE EXAMPLE 6-1 Output From the `ifconfig -a` Command

```
# /usr/sbin/ifconfig -a

lo0: flags=1000849<UP,LOOPBACK,RUNNING,MULTICAST,IPv4> mtu 8232 index 1
inet 127.0.0.1 netmask ff000000
dmfe0: flags=1000843<UP,BROADCAST,RUNNING,MULTICAST,IPv4> mtu 1500 index 2
inet 10.0.0.10 netmask ff000000 broadcast 10.255.255.255
ether 0:3:ba:5:11:ea
dmfel: flags=1000843<UP,BROADCAST,RUNNING,MULTICAST,IPv4> mtu 1500 index 3
inet 90.0.0.1 netmask ff000000 broadcast 10.255.255.255
ether 0:3:ba:5:11:ea
```

The example in CODE EXAMPLE 6-1 gives us the following information:

- Service processor IP address: 10.0.0.10 (for the master Storage Service Processor)
- Netmask being used : 255.0.0.0 ff (HEX) = 255 (DECIMAL)
- Broadcast being used : 10.255.255.255

1. **Power on the Network Terminal Concentrator and the Modem and press the TEST button on the front of the Network Terminal Concentrator . The TEST button can be pressed while powering on or within 10 seconds after powering on. The amber LED that is on the left side of the TEST button will illuminate, indicating that the Network Terminal Concentrator is in configuration mode.**

You can expect to see the Network Terminal Concentrator front panel LEDs flash for a few minutes until they stop with the following indications:

POWER (on solid)
UNIT (on solid)
NET (on solid)
ACTIVE (flashing)

The modem LEDs also go through a startup sequence until they stop with the following indications:

HS (on solid possible after the first call to the Sun Solutions Center)
AA (on solid)
TR (on solid)
MR (on solid)
RS (on solid)
CS (on solid)

2. Log in to the Storage Service Processor if not already logged on.

See Chapter 5 for the procedures to log in to the Storage Service Processor.

3. From the external serial connection, gain access to the Network Terminal Concentrator console (port 1). The following example shows how `tip` would be used from a server.

```
# tip -9600 /dev/ttya
```

Note – The Network Terminal Concentrator console communicates at 9600 baud.

Expect to see the prompt shown in the following example:

```
monitor::
```

4. Configure the Ethernet interface. For example:

CODE EXAMPLE 6-2 Configuring the Ethernet Interface

```
monitor:: seq net
      Interface sequence: net
monitor:: addr
Enter Internet address [<uninitialized>]: 10.0.0.10
      Internet address: 10.0.0.10
Enter Subnet mask [255.255.0.0]: 255.0.0.0
      Subnet mask: 255.0.0.0
Enter Preferred load host Internet address [47.16.116.5]: 10.0.0.10
      Preferred load host address: 90.0.0.1
Enter Broadcast address [0.0.0.0]: 10.0.0.255
      Broadcast address: 10.0.0.255
Enter Preferred dump address [0.0.0.0]: 10.0.0.10
Select type of IP packet encapsulation (ieee802/ethernet) [<ethernet>]:
      Type of IP packet encapsulation: <ethernet>
Load Broadcast Y/N [N]:
monitor:: image
      Enter Image name [(ip)"oper.52.enet",
(mop)"OPER_52_ENET.SYS"]:: (mop)"OPER_52_ENET.SYS":: oper.52.enet
      Enter TFTP Load Directory [""]::
      Enter TFTP Dump path/filename ["dump.10.0.0.10"]::
```

6. Exit the `tip` session.

```
annex:~. (You will not see the "~" when exiting tip with "~.")
```

Note – If you have a problem exiting the `tip` session, press the Return key (Enter key) and then type in `~`.

7. Open an `ftp` session to the Network Terminal Concentrator .

Note – In the following code example, "`--->`" indicates commands entered at `ftp` prompts.

Note – The responses to the `ftp` commands are examples and should not be used as verification of successful command completion.

CODE EXAMPLE 6-4 Opening an `ftp` session to the Network Terminal Concentrator

```
# su (if not already root)
# cd /var/spool/erpcd/bfs
# ftp 10.0.0.10
Connected to 10.0.0.10
220 Annex FTP server (Version MICRO-XL-UX R10.0#2) ready.
---> Name (10.0.0.10:root): root
331 Password required for root.
---> Password: 10.0.0.10
NOTE: The password will be the ip address of the annex
230 User root logged in.
---> ftp> bin
200 Type set to I.
---> ftp> put config.annex
200 PORT command successful.
150 ASCII data connection for config.annex
(129.154.35.23,42503).
226 ASCII Transfer complete.
local: config.annex remote: config.annex
1499 bytes sent in 0.0014 seconds (1074.00 Kbytes/s)
---> ftp> bye
```

8. Use the na command to set up the Network Terminal Concentrator serial ports.

Note – In the following example, "--->" indicates responses to na command questions.

CODE EXAMPLE 6-5 Using the na Command to Set Up the Network Terminal Concentrator Serial Ports

```
# su (if not already root)
# cd /opt/annex
# ./na
Annex network administrator R14.1 October 22nd, 1997
--->      command: annex 10.0.0.10
          10.0.0.10: Micro-Annex-UX R10.0, 8 async ports

--->      command: read /var/spool/erpcd/bfs/config.ports

          setting annex parameters

          setting parameters for async port 1
          setting parameters for async port 2
          setting parameters for async port 3
          setting parameters for async port 4
          setting parameters for async port 5
          setting parameters for async port 6
          setting parameters for async port 7
          setting parameters for async port 8
          setting parameters for interface en0
          setting parameters for interface asy1
          setting parameters for interface asy2
          setting parameters for interface asy3
          setting parameters for interface asy4
          setting parameters for interface asy5
          setting parameters for interface asy6
          setting parameters for interface asy7
          setting parameters for interface asy8
--->      command: quit
```

9. Power off and on the Network Terminal Concentrator .

10. Test the dial in and dial out capability of the modem.

11. Contact the Sun Solution Center and ask for the Sun StorEdge Remote Response Start.

The following information is required by the Sun Solution Center:

- Customer contract number
- Customer contact name and phone number
- Phone number the Sun Solution Center will dial into for configuration and testing
- Specific configuration of Sun StorEdge T3+ arrays and routers
- Installer's name and contact number

Sun StorEdge 3900 and 6900 Series Setup Instructions

This chapter provides a listing of the tasks that should be performed when setting up Sun StorEdge 3900 and 6900 series storage systems.

This chapter is organized as follows:

- Section 7.1, “Sun StorEdge 3900 and 6900 Series Setup” on page 7-1
- Section 7.2, “Configuring a Sun StorEdge 3900 Series Storage System” on page 7-2
- Section 7.3, “Setting up LUN Slicing and Masking on the Sun StorEdge 3900 Series” on page 7-3
- Section 7.5, “Configuring a Sun StorEdge 6900 Series Storage System” on page 7-26
- Section 7.6, “Setting up Multiple Zones and VLUNs on the Sun StorEdge 6900 Series Storage System” on page 7-28
- Section 7.4, “Configuring the Sun StorEdge 3900SL or 3960 Storage System Cabinets into a Solution” on page 7-23
- Section 7.7, “Configuring the Sun StorEdge 6960 or 6960SL Storage System Cabinets into a Solution” on page 7-37

The following tools are required to perform the tasks in this chapter.

- Laptop or server terminal

7.1 Sun StorEdge 3900 and 6900 Series Setup

Both the Sun StorEdge 3900 and 6900 series storage systems are delivered with the same configuration for all Sun StorEdge T3+ array partner groups. The first step in configuring the Sun StorEdge 3900 or 6900 series is to determine if the default configuration is appropriate for the expected workload.

The Sun StorEdge T3+ array partner groups can be reconfigured using the configuration utilities described in *Sun StorEdge 3900 and 6900 Series 1.1 Reference and Service Manual*.

7.2 Configuring a Sun StorEdge 3900 Series Storage System

The following is a list of the tasks that should be performed when setting up a Sun StorEdge 3900 series storage system.

1. Connect the Fibre Channel (FC) Host Bus Adapters (HBA) pairs to the Sun StorEdge 3900 series storage system switches. Plug both HBAs in a redundant pair in to the same port on both switches to establish connectivity to both ports on the Sun StorEdge T3+ array partner group.

Note – When connecting a Sun StorEdge 3900SL storage system, the Fibre Channel Host Bus Adapters and the Sun StorEdge T3+ array partner group must be connected using the instructions supplied with the external switches supplied by the customer. After the connections are made, configuring the storage system proceeds as described here.

2. Determine the appropriate setting for the switch port. For example:
 - Solaris servers should connect to the default F port setting (see Chapter 9).
 - Red Hat Linux servers require the host F port settings (see Chapter 12).
3. Determine what multipathing software the host will be using:
 - Solaris servers using the Sun StorEdge Traffic Manager software use the default Sun StorEdge T3+ array `mp_support` system parameter and no additional changes are necessary.
 - Systems using VERITAS Dynamic Multipathing (DMP) require that the Sun StorEdge T3+ array `mp_support` system parameter be changed to `rw`. This can be accomplished by running the `modifyt3params(1M)` command on the Storage Service Processor.

See Chapter 5 for instructions about logging in to the Storage Service Processor.

The default Sun StorEdge T3+ array configuration is RAID5 with 2 LUNs per partner pair. If you wish to modify this configuration, run the `modifyt3config(1M)` command on the Storage Service Processor.

7.3 Setting up LUN Slicing and Masking on the Sun StorEdge 3900 Series

The batch process for creating LUN slicing and masking is accomplished by running the `runsecfg(1M)` command on the Storage Service Processor. The `runsecfg(1M)` command initiates a series of menus that allow you to set up parameters for LUN slicing and masking. See Chapter 5 for instructions about logging in to the Storage Service Processor.

7.3.1 Enabling Sun StorEdge T3+ Array Volume Slicing

The following menus are examples of enabling a volume for LUN slicing.

After logging in to the Storage Service Processor, issue the following command:

```
# /opt/SUNWsecfg/runsecfg
```

Select “T3+ Configuration Utility” from the main menu and the following menu is displayed:

```
Sun StorEdge T3+ Array Main Menu

1) Display Sun StorEdge T3+ Array(s)
2) Save Sun StorEdge T3+ Array Configuration
3) Configure Sun StorEdge T3+ Array(s)
4) Restore Sun StorEdge T3+ Array Configuration
5) Verify Sun StorEdge T3+ Array Configuration
6) Modify Sun StorEdge T3+ Array Sys Parameters
7) Display Sun StorEdge T3+ Array(s) Configuration Status
8) Manage Sun StorEdge T3+ Array LUN Slicing
9) Manage Sun StorEdge T3+ Array LUN Masking
10) Help
11) Return
Select option above:> 8
```

Enabling LUN slicing continued.

```
MANAGE Sun StorEdge T3+ Array LUN SLICING MENU

1) Display Sun StorEdge T3+ Array LUN Slice/Mask Info
2) Create Sun StorEdge T3+ Array LUN Slice
3) Remove Sun StorEdge T3+ Array LUN Slice
4) Enable Sun StorEdge T3+ Array Volume Slicing
5) Return
Select option Above:> 4

Retrieving current list of available Sun StorEdge T3+ Array(s)...

AVAILABLE Sun StorEdge T3+ Array(s)

1) t3b0
2) ALL
3) Return
Select option above:> 1
Volslice is already enabled on t3b0
```

7.3.2 Creating Sun StorEdge T3+ Array LUN Slices

The following menu examples create slices on Sun StorEdge T3+ arrays.

After logging in to the Storage Service Processor, issue the following command:

```
# /opt/SUNWsecfg/runsecfg
```

Select "T3+ Configuration Utility" from the main menu and the following menu is displayed:

```
Sun StorEdge T3+ Array Main Menu

1) Display Sun StorEdge T3+ Array(s)
2) Save Sun StorEdge T3+ Array Configuration
3) Configure Sun StorEdge T3+ Array(s)
4) Restore Sun StorEdge T3+ Array Configuration
5) Verify Sun StorEdge T3+ Array Configuration
6) Modify Sun StorEdge T3+ Array Sys Parameters
7) Display Sun StorEdge T3+ Array(s) Configuration Status
8) Manage Sun StorEdge T3+ Array LUN Slicing
9) Manage Sun StorEdge T3+ Array LUN Masking
10) Help
11) Return
Select option above:> 8
```

Creating LUN slicing continued.

```
MANAGE Sun StorEdge T3+ Array LUN SLICING MENU

1) Display Sun StorEdge T3+ Array LUN Slice/Mask Info
2) Create Sun StorEdge T3+ Array LUN Slice
3) Remove Sun StorEdge T3+ Array LUN Slice
4) Enable Sun StorEdge T3+ Array Volume Slicing
5) Return
Select option above:> 2

Retrieving current list of available Sun StorEdge T3+ Array(s)...

AVAILABLE Sun StorEdge T3+ Array(s)

1) t3b0
2)Return
Select option above:> 1

AVAILABLE VOLUMES LIST MENU

1) vol1 (46GB)
2) vol2 (20GB)
3) vol3 (10GB)
4) vol4 (20GB)
Select option above:> 1
Enter number of slices to be created (Max Available 5): 2
Enter size of slice in GB (range is 1GB - 38GB per slice): 2
Enter a slice name (10 alphanumeric characters or less): slicep
Creating slices on volume vol1 on t3b0
Successfully created 2 slices
t3b0 configuration is being saved
```

7.3.3 Sun StorEdge T3+ Array LUN Masking

The following menu examples show how to create LUN masking on Sun StorEdge T3+ arrays.

Log in to the Storage Service Processor. See Chapter 5 for instructions about logging in to the Storage Service Processor.

After logging in to the Storage Service Processor, issue the following command:

```
# /opt/SUNWsecfg/runsecfg
```

Select "T3+ Configuration Utility" from the main menu and the following menu is displayed:

Creating Sun StorEdge T3+ Array Group for LUN masking continued.

```
Sun StorEdge T3+ Array Main Menu

1) Display Sun StorEdge T3+ Array(s)
2) Save Sun StorEdge T3+ Array Configuration
3) Configure Sun StorEdge T3+ Array(s)
4) Restore Sun StorEdge T3+ Array Configuration
5) Verify Sun StorEdge T3+ Array Configuration
6) Modify Sun StorEdge T3+ Array Sys Parameters
7) Display Sun StorEdge T3+ Array(s) Configuration Status
8) Manage Sun StorEdge T3+ Array LUN Slicing
9) Manage Sun StorEdge T3+ Array LUN Masking
10) Help
11) Return
Select option above:> 9

MANAGE Sun StorEdge T3+ Array LUN MASKING MENU

1) Display Sun StorEdge T3+ Array LUN Slice/Mask Info
2) Create Sun StorEdge T3+ Array Group
3) Remove Sun StorEdge T3+ Array Group
4) Add to Sun StorEdge T3+ Array Group
5) Delete from Sun StorEdge T3+ Array Group
6) Set Sun StorEdge T3+ Array LUN Permissions
7) Return
Select option above:> 2

Retrieving current list of available Sun StorEdge T3+ Array(s)...

AVAILABLE Sun StorEdge T3+ Array(s)

1) t3b0
2) Return
Select option above:> 1
Enter a group name (15 alphanumeric characters or less): groupab
Enter the associated Host Bus Adapter WWN: 1234567890123456
```

Creating Sun StorEdge T3+ Array Group for LUN masking continued.

```
Do you want to set permissions for a LUN to this group now? [y|n]: y

AVAILABLE T3+ LUNs MENU

 1) slicep0(LUN0)
 2) slicep1(LUN1)
 3) test020(LUN4)
 4) test021(LUN5)
 5) test023(LUN7)
 6) test030(LUN8)
 7) test031(LUN9)
 8) test032(LUN10)
 9) test033(LUN11)
10) test040(LUN12)
11) test041(LUN13)
12) test042(LUN14)
Select option above:> 2

LUN PERMISSIONS MENU

 1) rw
 2) ro
 3) none
Select option above:> 1
Creating group groupab with WWN 1234567890123456 as a group element
on t3b0
Successfully created group groupab
t3b0 Configuration is being saved
```

7.3.4 Setting Sun StorEdge T3+ Array LUN Permissions on a Group or WWN

The following menu examples show setting the permissions for the Sun StorEdge T3+ array for a group or a WWN.

After logging in to the Storage Service Processor, issue the following command:

```
# /opt/SUNWsecfg/runsecfg
```

Select "T3+ Configuration Utility" from the main menu and the following menu is displayed:

```
Sun StorEdge T3+ Array Main Menu
1) Display Sun StorEdge T3+ Array(s)
2) Save Sun StorEdge T3+ Array Configuration
3) Configure Sun StorEdge T3+ Array(s)
4) Restore Sun StorEdge T3+ Array Configuration
5) Verify Sun StorEdge T3+ Array Configuration
6) Modify Sun StorEdge T3+ Array Sys Parameters
7) Display Sun StorEdge T3+ Array(s) Configuration Status
8) Manage Sun StorEdge T3+ Array LUN Slicing
9) Manage Sun StorEdge T3+ Array LUN Masking
10) Help
11) Return
Select option above:> 9
```

Setting LUN permissions on a group or WWN continued.

```
MANAGE Sun StorEdge T3+ Array LUN MASKING MENU

1) Display Sun StorEdge T3+ Array LUN Slice/Mask Info
2) Create Sun StorEdge T3+ Array Group
3) Remove Sun StorEdge T3+ Array Group
4) Add to Sun StorEdge T3+ Array Group
5) Delete from Sun StorEdge T3+ Array Group
6) Set Sun StorEdge T3+ Array LUN Permissions
7) Return
Select option above:> 6

Retrieving current list of available Sun StorEdge T3+ Array(s)...

AVAILABLE Sun StorEdge T3+ Array(s)

1) t3b0
2) Return
Select option above:> 1

Do you want to set LUN permissions on a group or WWN [g|w] : g

AVAILABLE T3+ GROUP(S) MENU

1) bobgroup1
2) groupab
3) mark_ronly
4) markgroup1
5) pad
6) test
7) wst5_1
8) wst5_2
Select option above:> 5
```

Setting LUN permissions on a group or WWN continued.

```
AVAILABLE T3+ LUNs MENU

1) slicep0(LUN0)
2) slicep1(LUN1)
3) test020(LUN4)
4) test021(LUN5)
5) test023(LUN7)
6) test030(LUN8)
7) test031(LUN9)
8) test032(LUN10)
9) test033(LUN11)
10) test040(LUN12)
11) test041(LUN13)
12) test042(LUN14)
13) ALL
Select option above:> 5

LUN PERMISSIONS MENU

1) rw
2) ro
3) none
Select option above:> 1
Setting permissions of LUN 7 for GROUP pad to rw on t3b0
Successfully set LUN 7 permissions to rw for GROUP pad
t3b0 Configuration is being saved
```

7.3.5 Deleting a WWN from a Sun StorEdge T3+ Array Group

The following menu examples show how to delete a WWN from a Sun StorEdge T3+ array group.

After logging in to the Storage Service Processor, issue the following command:

```
# /opt/SUNWsecfg/runsecfg
```

Select "T3+ Configuration Utility" from the main menu and the following menu is displayed:

```
Sun StorEdge T3+ Array Main Menu

1) Display Sun StorEdge T3+ Array(s)
2) Save Sun StorEdge T3+ Array Configuration
3) Configure Sun StorEdge T3+ Array(s)
4) Restore Sun StorEdge T3+ Array Configuration
5) Verify Sun StorEdge T3+ Array Configuration
6) Modify Sun StorEdge T3+ Array Sys Parameters
7) Display Sun StorEdge T3+ Array(s) Configuration Status
8) Manage Sun StorEdge T3+ Array LUN Slicing
9) Manage Sun StorEdge T3+ Array LUN Masking
10) Help
11) Return
Select option above:> 9
```

Deleting a WWN from a group continued.

```
MANAGE Sun StorEdge T3+ Array LUN MASKING MENU

1) Display Sun StorEdge T3+ Array LUN Slice/Mask Info
2) Create Sun StorEdge T3+ Array Group
3) Remove Sun StorEdge T3+ Array Group
4) Add to Sun StorEdge T3+ Array Group
5) Delete from Sun StorEdge T3+ Array Group
6) Set Sun StorEdge T3+ Array LUN Permissions
7) Return
Select option above:> 5

Retrieving current list of available Sun StorEdge T3+ Array(s)...

AVAILABLE Sun StorEdge T3+ Array(s)

1) t3b0
2) Return
Select option above:> 1

AVAILABLE T3+ GROUP(S) MENU

1) bobgroup1
2) groupab
3) mark_ronly
4) markgroup1
5) pad
6) test
7) wst5_1
8) wst5_2
Select option above:> 1

AVAILABLE T3+ WWN(s)
1) 508002000002D180
2) 1432567890123456
3) 1231267890123456
Select option above:> 3
Deleting WWN 1231267890123456 from Group bobgroup1 on t3b0
Successfully deleted WWN 1231267890123456 from group bobgroup1
t3b0 configuration is being saved
```

7.3.6 Adding a WWN to a Sun StorEdge T3+ Array Group

The following menu examples show how to add a WWN to a Sun StorEdge T3+ array group.

After logging in to the Storage Service Processor, issue the following command:

```
# /opt/SUNWsecfg/runsecfg
```

Select “T3+ Configuration Utility” from the main menu and the following menu is displayed:

```
Sun StorEdge T3+ Array Main Menu

1) Display Sun StorEdge T3+ Array(s)
2) Save Sun StorEdge T3+ Array Configuration
3) Configure Sun StorEdge T3+ Array(s)
4) Restore Sun StorEdge T3+ Array Configuration
5) Verify Sun StorEdge T3+ Array Configuration
6) Modify Sun StorEdge T3+ Array Sys Parameters
7) Display Sun StorEdge T3+ Array(s) Configuration Status
8) Manage Sun StorEdge T3+ Array LUN Slicing
9) Manage Sun StorEdge T3+ Array LUN Masking
10) Help
11) Return
Select option above:> 9
```

Adding a group to a Sun StorEdge T3+ array group continued.

```
MANAGE Sun StorEdge T3+ Array LUN MASKING MENU

1) Display Sun StorEdge T3+ Array LUN Slice/Mask Info
2) Create Sun StorEdge T3+ Array Group
3) Remove Sun StorEdge T3+ Array Group
4) Add to Sun StorEdge T3+ Array Group
5) Delete from Sun StorEdge T3+ Array Group
6) Set Sun StorEdge T3+ Array LUN Permissions
7) Return
Select option above:> 4

Retrieving current list of available Sun StorEdge T3+ Array(s)...

AVAILABLE Sun StorEdge T3+ Array(s)
1) t3b0
2) Return
Select option above:> 1

AVAILABLE T3+ GROUP(S) MENU

1) bobgroup1
2) groupab
3) mark_ronly
4) markgroup1
5) pad
6) test
7) wst5_1
8) wst5_2
Select option above:> 1
Enter the WWN to add to the group:1231267890123456
Adding WWN 1231267890123456 to Group bobgroup1 on t3b0
Successfully added WWN 1231267890123456 to group bobgroup1
t3b0 Configuration is being saved
```

7.3.7 Removing a Sun StorEdge T3+ Array Group

The following menu examples show how to remove a Sun StorEdge T3+ array group.

After logging in to the Storage Service Processor, issue the following command:

```
# /opt/SUNWsecfg/runsecfg
```

Select "T3+ Configuration Utility" from the main menu and the following menu is displayed:

```
Sun StorEdge T3+ Array Main Menu

1) Display Sun StorEdge T3+ Array(s)
2) Save Sun StorEdge T3+ Array Configuration
3) Configure Sun StorEdge T3+ Array(s)
4) Restore Sun StorEdge T3+ Array Configuration
5) Verify Sun StorEdge T3+ Array Configuration
6) Modify Sun StorEdge T3+ Array Sys Parameters
7) Display Sun StorEdge T3+ Array(s) Configuration Status
8) Manage Sun StorEdge T3+ Array LUN Slicing
9) Manage Sun StorEdge T3+ Array LUN Masking
10) Help
11) Return
Select option above:> 9
```

Removing a Sun StorEdge T3+ array group continued.

```
MANAGE Sun StorEdge T3+ Array LUN MASKING MENU

1) Display Sun StorEdge T3+ Array LUN Slice/Mask Info
2) Create Sun StorEdge T3+ Array Group
3) Remove Sun StorEdge T3+ Array Group
4) Add to Sun StorEdge T3+ Array Group
5) Delete from Sun StorEdge T3+ Array Group
6) Set Sun StorEdge T3+ Array LUN Permissions
7) Return
Select option above:> 3

Retrieving current list of available Sun StorEdge T3+ Array(s)

AVAILABLE Sun StorEdge T3+ Array(s)

1) t3b0
2) Return
Select option above:> 1

AVAILABLE T3+ GROUP(S) MENU

1) bbbyyy
2) bobgroup1
3) groupab
4) mark_ronly
5) markgroup1
6) pad
7) test
8) wst5_1
9) wst5_2
10) All
Select option above:> 1
Deleting bbbyyy group from t3b0
Successfully deleted bbbyyy group
t3b0 configuration is being saved
```

7.3.8 Displaying the Composite Map of a Sun StorEdge T3+ Array

The following menu examples display the composition and location of slices on a specified Sun StorEdge T3+ array.

After logging in to the Storage Service Processor, issue the following command:

```
# /opt/SUNWsecfg/runsecfg
```

Select "T3+ Configuration Utility" from the main menu and the following menu is displayed:

```
Sun StorEdge T3+ Array Main Menu

1) Display Sun StorEdge T3+ Array(s)
2) Save Sun StorEdge T3+ Array Configuration
3) Configure Sun StorEdge T3+ Array(s)
4) Restore Sun StorEdge T3+ Array Configuration
5) Verify Sun StorEdge T3+ Array Configuration
6) Modify Sun StorEdge T3+ Array Sys Parameters
7) Display Sun StorEdge T3+ Array(s) Configuration Status
8) Manage Sun StorEdge T3+ Array LUN Slicing
9) Manage Sun StorEdge T3+ Array LUN Masking
10) Help
11) Return
Select option above:> 8
```

Displaying the composite map continued.

```
MANAGE Sun StorEdge T3+ Array LUN SLICING MENU

1) Display Sun StorEdge T3+ Array LUN slice/Mask Info
2) Create Sun StorEdge T3+ Array LUN Slice
3) Remove Sun StorEdge T3+ Array LUN Slice
4) Enable Sun StorEdge T3+ Array Volume Slicing
5) Return
Select option above:> 1

Retrieving current list of available Sun StorEdge T3+ Array(s)...

AVAILABLE Sun StorEdge T3+ Array(s)
1) t3b0
2) ALL
3) Return
Select option above:> 1

LIST SLICE MENU

1) Display Composite Map
2) List Slice Information
3) List LUN Map Information
4) List LUN Permission Information
5) Return
Select option above:> 1
```

Displaying the composite map continued.

SLICE NAME	SLICE NUMBER	LUN NUMBER	SIZE (GB)	VOLUME NAME
Unused	-	-	8.0	vol1
four 2	2	2	4.0	vol1
Unused	-	-	38.0	vol1
test020	4	4	10.0	vol2
test021	5	5	10.0	vol2
Unused	-	-	10.0	vol2
test023	7	7	10.0	vol2
Unused	-	-	10.0	vol2
test030	8	8	10.0	vol3
test031	9	9	10.0	vol13
test032	10	10	10.0	vol13
test033	11	11	10.0	vol13
Unused	-	-	10.0	vol13
test040	12	12	10.0	vol14
test041	13	13	10.0	vol14
test042	14	14	10.0	vol14
Unused	-	-	20.0	vol14

VOLUME NAME	NUMBER OF SLICES	NUMBER OF FREE BLOCKS	TOTAL FREE SPACE (GB)	LARGEST FREE BLOCK (GB)
vol1	1	2	46.0	38.0
vol2	3	2	20.0	10.0
vol3	4	1	10.0	10.0
vol4	3	1	20.0	20.0
TOTALS	11	6	96.0	

Displaying the composite map continued.

```
*****  
  
GROUP NAME          HBA WWN  
-----  
wst5_1              210100E08B243854  
wst5_1              210100E08B2357F9  
wst5_2              210000E08B0357F9  
wst5_2              210000E08B043854  
wst5_2              1234567890123456  
markgroup1         508002000002D180  
markgroup1         508002000002D181  
markgroup1         1234567891235657  
markgroup1         1234568891234567  
bobgroup1          508002000002D180  
bobgroup1          1432567890123456  
pad                210100E08B243854  
mark_ronly         1234567899123456  
bbbyyy            1234567777777777  
test               0987654321098765  
-----           210101E08B243854  
-----           1234567891234567  
-----           1234568891234569  
-----           8ABCDEF012345679
```

Note – The dashes under the GROUP NAME heading indicate that the corresponding HBA WWNs are registered on the Sun StorEdge T3+ array but are not part of the group.

Displaying the composite map continued.

```

*****

SLICE NAME      LUN  HBA WWN          GROUP NAME      PERMISSIONS
                  NUMBER
-----
four2           2    default          --              -- none none
test020         4    default          --              -- none none
test020         4    210000E08B043854 wst5_2         none rw rw
test020         4    0987654321098765 test           none rw rw
test021         5    default          --              -- none none
test021         5    210000E08B043854 wst5_2         none rw rw
test021         5    0987654321098765 test           none rw rw
test023         7    default          --              -- none none
test023         7    210000E08B043854 wst5_2         none rw rw
test023         7    0987654321098765 test           none rw rw
test030         8    default          --              -- none none
test030         8    210000E08B043854 wst5_2         none rw rw
test030         8    0987654321098765 test           none rw rw
test031         9    default          --              -- none none
test031         9    210000E08B043854 wst5_2         none rw rw
test031         9    0987654321098765 test           none rw rw
test032         10   default          --              -- none none
test032         10   210000E08B043854 wst5_2         none rw rw
test032         10   0987654321098765 test           none rw rw
test033         11   default          --              -- none none
test033         11   210000E08B043854 wst5_2         none rw rw
test033         11   0987654321098765 test           none rw rw
test040         12   default          --              -- none none
test040         12   210000E08B043854 wst5_2         none rw rw
test040         12   0987654321098765 test           none rw rw
test041         13   default          --              -- none none
test041         13   210000E08B043854 wst5_2         none rw rw
test041         13   0987654321098765 test           none rw rw
test042         14   default          --              -- none none
test042         14   210000E08B043854 wst5_2         none rw rw
test042         14   0987654321098765 test           none rw rw

*****

```

7.3.9 Next Step

If you have a Sun StorEdge 3900SL or 3960 storage system that has the expansion cabinet attached, proceed to Section 7.4, “Configuring the Sun StorEdge 3900SL or 3960 Storage System Cabinets into a Solution” on page 7-23, otherwise, proceed to Chapter 8.

7.4 Configuring the Sun StorEdge 3900SL or 3960 Storage System Cabinets into a Solution

Use FIGURE 3-1 for the naming conventions used for Sun StorEdge T3+ arrays in a Sun StorEdge 3900 Series Configuration.

1. **Identify the media access control (MAC) address for the new Sun StorEdge T3+ array in the second cabinet.**

The MAC address of the Sun StorEdge T3+ array can be found on a card inside the front cover of the device.

2. **Log in to the Storage Service Processor.**

See Chapter 5 for instructions about logging in to the Storage Service Processor.

3. **Add the new MAC address in to the `/etc/ethers` file on the Storage Service Processor. See the `ethers(4)` man page for details. For example:**

```
8:0:20:7d:93:7e array-name
```

4. **Make certain the reverse address resolution protocol (RARP) daemon (`in.rarpd(1M)`) is running on the Storage Service Processor.**

```
msp0# ps -eaf | grep rarpd
root    317    314    0      Sep 28 ?        0:00 /usr/sbin/in.rarpd dmfe 1
msp0#
```

If the daemon is not running, start it with the following command:

```
msp0# /usr/sbin/in.rarpd dmfe 1
```

5. Power on the Sun StorEdge T3+ array in order to see the new IP address.
6. Start a telnet session to the new Sun StorEdge T3+ array.

```
# /bin/telnet t3bx
login: root
Password: Return

T3B Release 2.01.00 2002/03/22 18:35:03 (192.168.209.243)
Copyright (C) 1997-2001 Sun Microsystems, Inc.
All Rights Reserved.
```

7. Set a password on the Sun StorEdge T3+ array (if it has not already been done).

Note – For the Sun StorEdge 3900 series storage system, all Sun StorEdge T3+ arrays in a cabinet must use the same password. If one of the other arrays already has a password set, you must use the same password for the new array.

```
:/:<1> passwd
OLD password: Return
NEW password: new password
NEW password (confirm): new password
:/:<2>
```

8. Type `exit` to exit the telnet session.
9. Type the following to transfer the `syslog.config` file to the Sun StorEdge T3+ array:

```
mspo# ftp t3bx
Connected to t3bx
220 192.168.0.nn FTP server ready.
Name(t3bx:root): Return
331 Password required for root.
Password: new password
230 User root logged in.
ftp> put /opt/SUNWsecfg/etc/syslog.conf /etc/syslog.conf
200 PORT command successful.
150 Opening ASCII mode data connection for /etc/syslog.conf
242 bytes sent in 0.00072 seconds (328.23 Kbytes/s)
ftp> quit
```

10. If a password was set in Step 7, remove the password if other Sun StorEdge T3+ arrays have no password. Start a telnet session to the Sun StorEdge T3+ array.

```
:/:<1> password
OLD password: password
NEW password: Return
NEW password (confirmed): Return
:/:<2> exit
```

11. Save the Sun StorEdge T3+ array configuration by typing:

```
mosp0# /opt/SUNWsecfg/bin/savet3config -n ALL
```

If you want to change the default configuration of the Sun StorEdge T3+ array from RAID 5 with two LUNs, continue with Step 13 through Step 20.

12. Verify the Sun StorEdge T3+ arrays by typing:

```
mosp0# /opt/SUNWsecfg/bin/checkt3config -n ALL -v
```

This command checks the current Sun StorEdge T3+ array configuration with the previously saved configuration. Any changes in the information are reported. The PASSWD environment must be set for this command to execute.

13. Log in to the Storage Service Processor and use the `runsecfg(1M)` command to start the character user interface.
14. Select T3+ Configuration Utility from the Main Menu.
15. When prompted, enter the password for the Sun StorEdge T3+ array. Press Return if no password has been set.
16. Select the Configure T3+ option.
17. Select the Sun StorEdge T3+ host name that you added.
18. Select the Default or Custom option to configure the new Sun StorEdge T3+ array.

Note – This step takes two to three hours, depending on the configuration of the Sun StorEdge T3+ array.

19. Type the following command to set the Golden default configuration of the solution box in the Storage Automated Diagnostic Environment (StorADE):

```
mosp0# /opt/SUNWstade/bin/config_solution -m model-number
```

The model-number choices are: 3910, 3960, and 3900SL. The choice with the SL suffix represents the Sun StorEdge 3900 series storage systems that have the front end switches in the server rather than in the storage system cabinet.

20. Use the Sun StorEdge T3+ array LUN slicing and masking for additional configuration options.

See Chapter 7.2 for a description of the sequence of menus to configure LUN slicing and masking.

7.5 Configuring a Sun StorEdge 6900 Series Storage System

Configuring the Sun StorEdge 6900 series storage system is a multiple step process. The Sun StorEdge 6900 series storage system enables the user to carve the underlying storage Logical Unit Number (LUN) in to several smaller devices called Virtual Logical Unit Number (VLUNs). To prevent data corruption, the Sun StorEdge 6900 series storage system uses a security feature called *LUN masking* to present a set of VLUNs to only the specified HBAs.

LUN masking is enabled by creating virtualization engine zones that contain both HBA and VLUN devices. It is recommended that each attached host have a minimum of two HBA connections to the Sun StorEdge 6900 series storage system for redundancy, and to enable host-based multipathing (for example, Sun StorEdge Traffic Manager) using the redundant HBA pair. Each VLUN presented to the host is added to virtualization engine zones associated with both HBAs, and the host sees the VLUNs down both channels.

The following tasks should be performed when you are setting up a Sun StorEdge 6900 series storage system:

1. At initial installation, attach all FC HBA pairs to the Sun StorEdge 6900 series storage system switches (one HBA per switch in the redundant pair).

Note – When connecting a Sun StorEdge 6910SL or 6960SL storage system, the Fibre Channel Host Bus Adapters must be connected using the instructions supplied with the external switches supplied by the customer. After the connections are made, configuring the storage system proceeds as described here.

2. After all HBAs are attached and the LEDs on the switch indicate they are online, run the following command from the Storage Service Processor. See Chapter 5 for instructions about logging in to the Storage Service Processor. On a Sun StorEdge 6910 or 6910SL storage system, run `savevemap -n v1` and on the Sun StorEdge 6960 or 6960SL storage system, run both `savevemap -n v1` and `savevemap -n v2`.

```
# /opt/SUNWsecfg/bin/savevemap -n [v1|v2]
```

If you are using the Sun StorEdge Configuration Utilities graphical user interface (GUI), select Sun StorEdge Series Config, then go to Manage Config Files, and select Save Virtualization Engine Map. When the virtualization engine maps are saved, the HBAs are available to set up zoning (LUN masking).

3. On each host attached to the Sun StorEdge 6900 series storage system, determine the worldwide name (WWN) for each channel.
4. Create a virtualization engine zone for each HBA. Through the `runsecfg(1M)` menu, select Virtualization Engine Configuration Utility, then select Manage Virtualization Engine Zones, and finally select Create Virtualization Engine Zone for each initiator associated with the virtualization engine pairs. When an initiator is selected, a list of available HBAs is displayed. Select one from the list, match it to the correct host and channel, and enter a name for the virtualization engine zone. You may create all your zones in a single batch process by responding with an “m” to the following prompt: Do you want to create single or multiple zone(s) [s|m]. It is much faster to create all the zones at one time. Also, if you have an environment where you need multiple HBAs in the same zone, you will need to specify a unique alias name for each HBA as well.

See Section 7.6, “Setting up Multiple Zones and VLUNs on the Sun StorEdge 6900 Series Storage System” on page 7-28 for a description of the complete procedure.
5. After the virtualization engine zones have been created, create VLUNs and assign them to the virtualization engine zones associated with the redundant HBAs from a host. Through the `runsecfg` menu, first select Virtualization Engine Configuration Utility, then Manage VLUNs, and finally Create VLUNs. Then select the disk pool from which to create the VLUNs, specify the number and size of VLUNs, and choose at least one zone from each virtualization engine initiator to assign the new VLUNs. For best performance, you may create all VLUNs and

add them to zones in a single batch process by responding “m” to the following prompt: Do you want to create VLUNs in single or multiple disk pool(s) [s|m].

See Section 7.6, “Setting up Multiple Zones and VLUNs on the Sun StorEdge 6900 Series Storage System” on page 7-28 for a description of the complete procedure.

7.6 Setting up Multiple Zones and VLUNs on the Sun StorEdge 6900 Series Storage System

The batch process for creating multiple zones and VLUNs is accomplished by running the `runsecfg(1M)` command on the Storage Service Processor. The `runsecfg(1M)` command initiates a series of menus that allow you to set up the multiple zones and VLUNs. See Chapter 5 for instructions about logging in to the Storage Service Processor.

Note – Similar functionality is available from the Sun StorEdge Configuration Utilities GUI.

7.6.1 Creating Multiple Zones

After logging in to the Storage Service Processor, issue the following command:

```
# /opt/SUNWsecfg/runsecfg
```

Select “Virtualization Engine Configuration Utility” from the main menu and the following menu is displayed:

```
...  
VIRTUALIZATION ENGINE MAIN MENU  
  
1) Manage VLUNs  
2) Manage Virtualization Engine Zones  
3) Manage Configuration Files  
4) Manage Virtualization Engine Hosts  
5) MO Drive Failback Support  
6) Help  
7) Return  
Select option above:> 2
```

Creating multiple zones continued.

```
...
MANAGE ZONES MENU

1) Create Virtualization Engine Zones
2) Add Components to Virtualization Engine Zone
3) Delete Components from Virtualization Engine Zone
4) Remove Virtualization Engine Zone
5) View Virtualization Engine Map
6) Help
7) Return
Select zone option above:> 1

Do you want to create single of multiple zone(s) [s|m] : m

Do you want to create zones on v1, I00001 [y|n] : y

AVAILABLE WWN NUMBERS (v1 , I00001)

1) 210000E08B04AA55
2) 210100E08B2358F9
3) 210000E08B043654
4) 210000E08B043080
5) 210000E08B0358F9
6) 210100E08B2480C0
7) 210100E08B247FC0
8) Return
Select option above:> 1

Please enter the zone name (Recommendation : host_channelID).
(Note : There is a max length of 15 chars for the zone name) : accts

Do you want to specify an alias name for the HBA?
(Note : alias name - is the user-defined HBA alias for the
associated WWN channel, if not specified, the zone name will be
used. Unique names should be used when multiple HBAs are in a
single zone, as in clusters). [y|n] : y

Please enter the HBA alias name (Note : There is a max length of
15 chars for the alias name) : ally1

Do you want to create more zones on v1, I00001 [y|n] : n

Do you want to create zones on v1, I0002 [y|n] : y
```

Creating multiple zones continued.

```
AVAILABLE WWN NUMBERS (v1 , I00002)

1) 210000E08B042F80
2) 210000E08B04E70F
3) 210100E08B243654
4) 210000E08B047FC0
5) 210000E08B0480C0
6) Return
Select option above:> 1

Please enter the zone name (Recommendation : host_channelID).
(Note : There is a max length of 15 chars for the zone name): csdata

Do you want to specify an alias name for the HBA?
(Note : alias name - is the user-defined HBA alias for the
associated WWN channel, if not specified, the zone name will be
used. Unique names should be used when multiple HBAs are in a
single zone, as in clusters). [y|n] : n

Do you want to create more zones on v1, I00002 [y|n] : n

Do you want to create zones on v2, I00001 [y|n] : y

AVAILABLE WWN NUMBERS (v2 , I00001)

1) 210100E08B243654
2) 210000E08B047FC0
3) 210000E08B0480C0
4) Return
Select option above:> 1

Please enter the zone name (Recommendation : host_channelID).
(Note : There is a max length of 15 chars for the zone name):
accts_alt

Do you want to specify an alias name for the HBA?
(note : alias name - is the user-defined HBA alias for the
associated WWN channel, if not specified, the zone name will be
used. Unique names should be used when multiple HBAs are in a
single zone, as in clusters). [y|n] : n

Do you want to create more zones on v2, I00001 [y|n] : n

Do you want to create zones on v2, I00002 [y|n] : y
```

Creating multiple zones continued.

```
AVAILABLE WWN NUMBERS (v2 , I00002)

1) 210000E08B043654
2) 210000E08B0358F9
3) 210100E08B2480C0
4) 210100E08B247FC0
5)Return
Select option above:> 1

Please enter the zone name (Recommendation : host_channelID).
(Note : There is a max length of 15 chars for the zone name):
csdata_alt

Do you want to specify an alias name for the HBA?
(note : alias name - is the user-defined HBA alias for the
associated WWN channel, if not specified, the zone name will be
used. Unique names should be used when multiple HBAs are in a
single zone, as in clusters). [y|n] : n

Do you want to create more zones on v2, I00002 [y|n] : n
Creating multiple virtualization engine zones .....

HBA alias ally1 : created successfully
zone accts : created successfully on v1 initiator I00001.
HBA alias csdata : created successfully.
zone csdata : created successfully on v1 initiator I00002.
HBA alias accts_alt : created successfully
zone accts_alt : created successfully on v2 initiator I00001.
HBA alias csdata_alt : created successfully.
zone csdata_alt : created successfully on v2 initiator I00002.

Finished creating multiple virtualization engine zones .....

Successfully saved map for virtualization engine pair v1
Successfully saved map for virtualization engine pair v2
```

7.6.2 Creating Multiple VLUNs (With Zones and Without Zones)

The following menu examples show how to create multiple VLUNs.

After logging in to the Storage Service Processor, issue the following command:

```
# /opt/SUNWsecfg/runsecfg
```

Select “Virtualization Engine Configuration Utility” from the main menu and the following menu is displayed:

```
...  
VIRTUALIZATION ENGINE MAIN MENU  
  
1) Manage VLUNs  
2) Manage Virtualization Engine Zones  
3) Manage Configuration Files  
4) Manage Virtualization Engine Hosts  
5) MP Drive Failback Support  
6) Help  
7) Return  
Select option above:> 1
```

Creating multiple VLUNs continued.

```
MANAGE VLUNs MENU

1) Create VLUNs
2) Remove VLUNs
3) View Virtualization Engine Map
4) Help
5) Return
Select VLUN option above:> 1

Do you want to create VLUNs in a single or multiple diskpools [s|m]
: m

Do you want to create VLUNs on v1 : [y|n] y

DISK POOLS FOR v1 (free space)

1) t3b00(102GB)
2) t3b01(102GB)
3) t3b02(272GB)
4) t3b03(272GB)
5) t3b20(102GB)
6) t3b21(102GB)
7) t3b22(272GB)
8) t3b23(272GB)
9) Return
Select option above:> 4

Note : Creation of each VLUN can take up to 1 minute.

Please enter the number of VLUN(s) that need to be created: 10

Please enter the size in GB for each VLUN (1 GB increments): 1
```

Creating multiple VLUNs continued.

```
Do you want to specify the zones? [y|n]: n

Do you want to specify a name for the VLUN? [y|n]: y

Please enter a name for the VLUN (There is a max length of 10 chars
including a unique ID prefix that will be added automatically): pad

Do you want to create more VLUNs on virtualization engine v1 :
[y|n] n

Do you want to create VLUNs on v2 : [y|n] y

DISK POOLS FOR v2 (free space)

1) t3b10(417GB)
2) teb11(457GB)
3) Return
Select option above:> 2

Note : Creation of each VLUN can take up to 1 minute.

Please enter the number of VLUN(s) that need to be created: 8

Please enter the size of GB for each VLUN (1 GB increments): 2

Do you want to specify the zones? [y|n]: y

AVAILABLE ZONES FOR (I00001, I00002)

1) accts(I00001)
2) csdata(I00001)
3) corp_alt(I00002)
4) finance_alt(I00002)
5) accts_alt(I00002)
6) csdata_alt(I00002)
7) Return
Enter zone numbers from the list above (multiple entries are space
separated):. 1 2 6

INFO: VLUNs will be added to the zone(s) accts, csdata, csdata_alt.
Enter y to continue or n to select zones again. [y|n] y

Do you want to specify a name for the VLUN? [y|n] n
```

Creating multiple VLUNs continued.

```
Do you want to create more VLUNs on virtualization engine v2 : [y|n] n
This functionality requires a check that T3+ physical LUN is mounted.
Please enter the Sun StorEdge T3+ array password: password
Creating multiple VLUN(s)
Checking that associated T3+ physical LUN is mounted...
VLUN T16384 : created Successfully on disk pool t3b03 with name lpad.
VLUN T16385 : created successfully on disk pool t3b03 with name 2pad.
VLUN T16386 : created successfully on disk pool t3b03 with name 3pad.
VLUN T16387 : Created successfully on disk pool t3b03 with name 4pad.
VLUN Y16388 : created successfully on disk pool t3b03 with name 5pad.
VLUN Y16389 : created successfully on disk pool t3b03 with name 6pad.
VLUN Y16390 : created successfully on disk pool t3b03 with name 7pad.
VLUN Y16391 : created successfully on disk pool t3b03 with name 8pad.
VLUN Y16392 : created successfully on disk pool t3b03 with name 9pad.
VLUN Y16393 : created successfully on disk pool t3b03 with name 10pad.
WARNING: VLUNs just created were not added to any zones.
This should be done to avoid data corruption. Refer to addtovezone
command.

WARNING: Adding VLUNs to more than two zones must be carefully managed
to avoid data corruption.
checking that associated T3+ physical LUN is mounted...
VLUN T16392 : created successfully on disk pool t3b11.
VLUN T16393 : created successfully on disk pool t3b11.
VLUN T16394 : created successfully on disk pool t3b11.
VLUN T16395 : created successfully on disk pool t3b11.
VLUN T16396 : created successfully on disk pool t3b11.
VLUN T16397 : created successfully on disk pool t3b11.
VLUN T16398 : created successfully on disk pool t3b11.
VLUN T16399 : created successfully on disk pool t3b11.
VLUN T16392 T16393 T16394 T16395 T16396 T16397 T16398 T16399 : added
successfully to zone accts.
VLUN T16392 T16393 T16394 T16395 T16396 T16397 T16398 T16399 : added
successfully to zone csdata.
```

Creating multiple VLUNs continued.

```
VLUN T16392 T16393 T16394 T16395 T16396 T16397 T16398 T16399 :  
added successfully to zone csdata_alt.  
  
Finished creating multiple VLUN(s) .....  
  
Successfully saved map for virtualization engine pair v1  
Successfully saved map for virtualization engine pair v2
```

7.6.3 Next Step

If you have a Sun StorEdge 6960 or 6960SL storage system with the expansion cabinet attached, proceed to Section 7.7, “Configuring the Sun StorEdge 6960 or 6960SL Storage System Cabinets into a Solution” on page 7-37, otherwise proceed to Chapter 8.

7.7 Configuring the Sun StorEdge 6960 or 6960SL Storage System Cabinets into a Solution

Use FIGURE 3-3 for the naming conventions used for Sun StorEdge T3+ arrays in a Sun StorEdge 6900 series configuration.

1. **Identify the MAC address for the new Sun StorEdge T3+ array in the second cabinet.**

The MAC address of the Sun StorEdge T3+ array can be found on a card inside the front cover of the device.

2. **Log in to the Storage Service Processor.**

See Chapter 5 for instructions about logging in to the Storage Service Processor.

3. **Add the new MAC address to the `/etc/ethers` file on the Storage Service Processor. See the `ethers(4)` man page for details. For example:**

```
8:0:20:7d:93:7e array-name
```

4. Make certain the reverse address resolution protocol (RARP) daemon (in.rarpd(1M)) is running on the Storage Service Processor.

```
msp0# ps -eaf | grep rarpd
root    317    314    0      Sep 28 ?        0:00 /usr/sbin/in.rarpd dmfe 1
msp0#
```

If the daemon is not running, start it with the following command:

```
msp0# /usr/sbin/in.rarpd dmfe 1
```

5. Power on the Sun StorEdge T3+ array in order to see the new IP address.
6. Start a telnet session to the new Sun StorEdge T3+ array.

```
# /bin/telnet t3bx
login: root
Password: Return

T3B Release 2.00 2001/07/12 19:35:12 (192.168.209.243)
Copyright (C) 1997-2001 Sun Microsystems, Inc.
All Rights Reserved.
```

7. Set a password on the Sun StorEdge T3+ array (if it has not already been done).

Note – For the Sun StorEdge 6900 series storage system, all Sun StorEdge T3+ arrays in a cabinet must use the same password. If one of the other arrays already has a password set, you must use the same password for the new array.

```
:/:<1> passwd
OLD password: Return
NEW password: new password
NEW password (confirm): new password
:/:<2>
```

8. Type `exit` to exit the telnet session.

9. Type the following to transfer the `syslog.config` file to the Sun StorEdge T3+ array:

```
msp0# ftp t3bx
Connected to t3bx
220 192.168.0.nn FTP server ready.
Name(t3bx:root): Return
331 Password required for root.
Password: new password
230 User root logged in.
ftp> put /opt/SUNWsecfg/etc/syslog.conf /etc/syslog.conf
200 PORT command successful.
150 Opening ASCII mode data connection for /etc/syslog.conf
242 bytes sent in 0.00072 seconds (328.23 Kbytes/s)
ftp> quit
```

10. If a password was set in Step 7, remove the password if other Sun StorEdge T3+ arrays have no password. Start a telnet session to the Sun StorEdge T3+ array.

```
:/:<1> password
OLD password: password
NEW password: Return
NEW password (confirmed): Return
:/:<2> exit
```

11. Set the environment variable for the Sun StorEdge T3+ array password, `PASSWD`.
12. Type the following command to set the Golden default configuration of the solution box in Storage Automated Diagnostic Environment (StorADE):

```
msp0# /opt/SUNWstade/bin/config_solution -m model-number
```

The model-number choices are: 6910, 6960, 6910SL, and 6960SL. The choices with the SL suffix represent the Sun StorEdge 6900 series storage systems that have the switches in the server rather than in the storage system cabinet.

13. Start the Storage Automated Diagnostic Environment and rediscover the new cabinet.

Refer to the *Storage Automated Diagnostic Environment User's Guide* for detailed instructions about discovery.

14. If a password was set for the Sun StorEdge T3+ array, set it:

```
#PASSWD=password  
#export PASSWD
```

15. Save the Sun StorEdge T3+ array configuration by typing:

```
mosp0# /opt/SUNWsecfg/bin/savet3config -n ALL
```

If you want to change the default configuration of the Sun StorEdge T3+ array from RAID 5 with two LUNs, continue with Step 17 through Step 23.

16. Verify the Sun StorEdge T3+ arrays by typing:

```
mosp0# /opt/SUNWsecfg/bin/checkt3config -n ALL -v
```

This command checks the current Sun StorEdge T3+ array configuration with the previously saved configuration. Any changes in the information are reported. The `PASSWD` environment must be set for this command to execute.

17. Log in to the Storage Service Processor and use the `runsecfg(1M)` command to start the character user interface.
18. Select T3+ Configuration Utility from the Main Menu.
19. When prompted, enter the password for the Sun StorEdge T3+ array. Press Return if no password has been set.
20. Select the Configure T3+ option.
21. Select the Sun StorEdge T3+ host name that you added.
22. Select the Default or Custom option to configure the new Sun StorEdge T3+ array.

Note – This step takes 2 to 10 hours, depending on the configuration of the Sun StorEdge T3+ array.

23. Create VLUNs and zones on the additional Sun StorEdge T3+ arrays in the expansion cabinet.

See Chapter 7.2 for a description of the sequence of menus to configure VLUNs and zones.

Connecting the Storage System to the Host Overview

Note – See www.sunsolve.sun.com and *Sun StorEdge 3900 and 6900 Series 1.1 Release Notes* for the software requirements for the host.

This chapter contains the following sections:

- Section 8.1, “Connecting the Sun StorEdge 3910 and 6910 Storage Systems to the Host” on page 8-1
- Section 8.2, “Connecting the Sun StorEdge 3960 or 6960 Storage Systems to the Host” on page 8-4
- Section 8.3, “Connecting the Sun StorEdge 3900SL, 6910SL or 6960SL Storage Systems to the Host” on page 8-7

The following tools are required to perform the tasks in this chapter:

- Laptop or server terminal

8.1 Connecting the Sun StorEdge 3910 and 6910 Storage Systems to the Host

In the Sun StorEdge 3910 and 6910 storage systems, the Sun StorEdge network Fibre Channel switch-8 switches (hereafter referred to as the *8-port Fibre Channel switch*) connect to the host through the Fibre Channel I/O ports on the switches. The Sun StorEdge 3910 storage system can provide from one to four HBA connections per switch and the Sun StorEdge 6910 storage system can provide from one to seven HBA connections per switch (a minimum of two connections per host). See FIGURE 8-1 and FIGURE 8-2 for diagrams of this cabling.

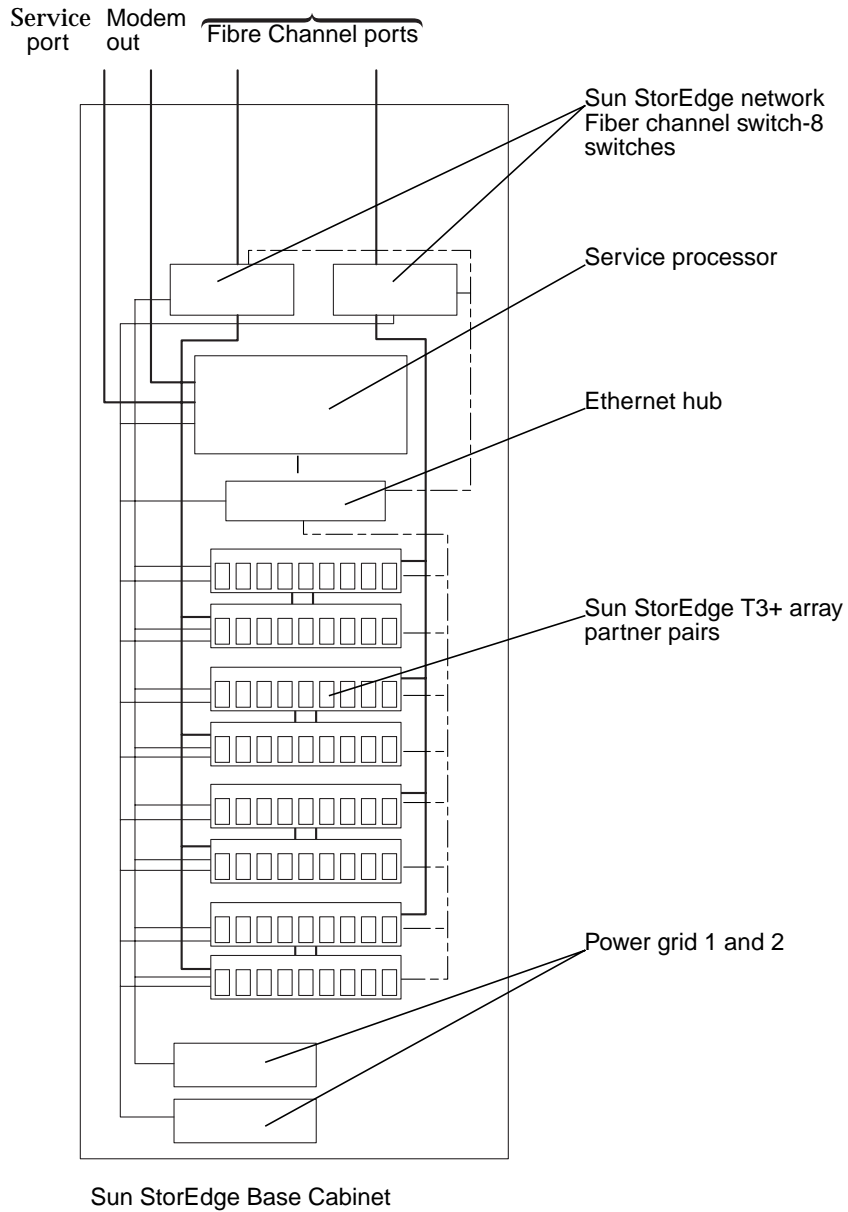

FIGURE 8-1 Sun StorEdge 3910 Storage System Cabling

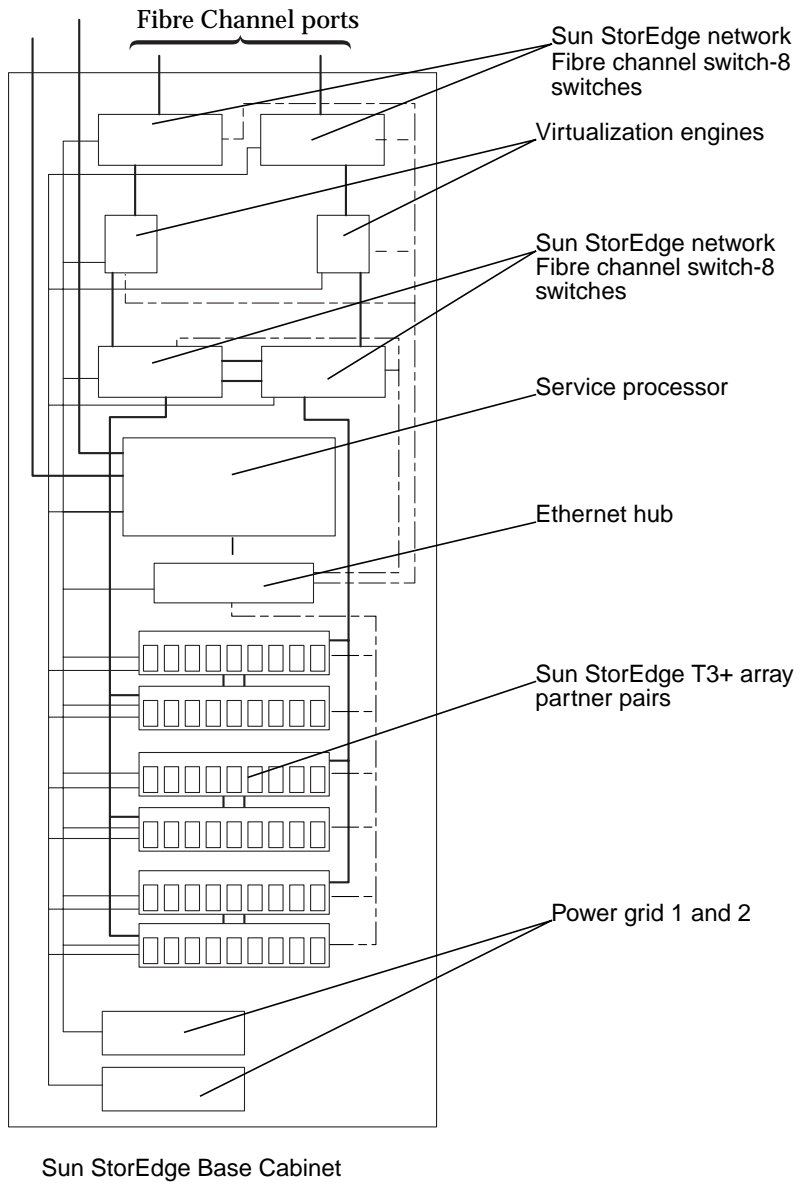

FIGURE 8-2 Sun StorEdge 6910 Storage System Cabling

8.2 Connecting the Sun StorEdge 3960 or 6960 Storage Systems to the Host

In the Sun StorEdge 3960 and 6960 storage systems, the Sun StorEdge network Fibre Channel switch-16 switch (hereafter referred to as the *16-port Fibre Channel switch*) connect to the host through the Fibre Channel I/O ports on the switches.

The Sun StorEdge 3960 storage systems provide one to seven HBA connections per switch (a minimum of two connections per host) and Sun StorEdge 6960 storage systems provide from 1 to 14 HBA connections per switch (a minimum of two connections per host).

See FIGURE 8-3 and FIGURE 8-4 for overview diagrams of this cabling.

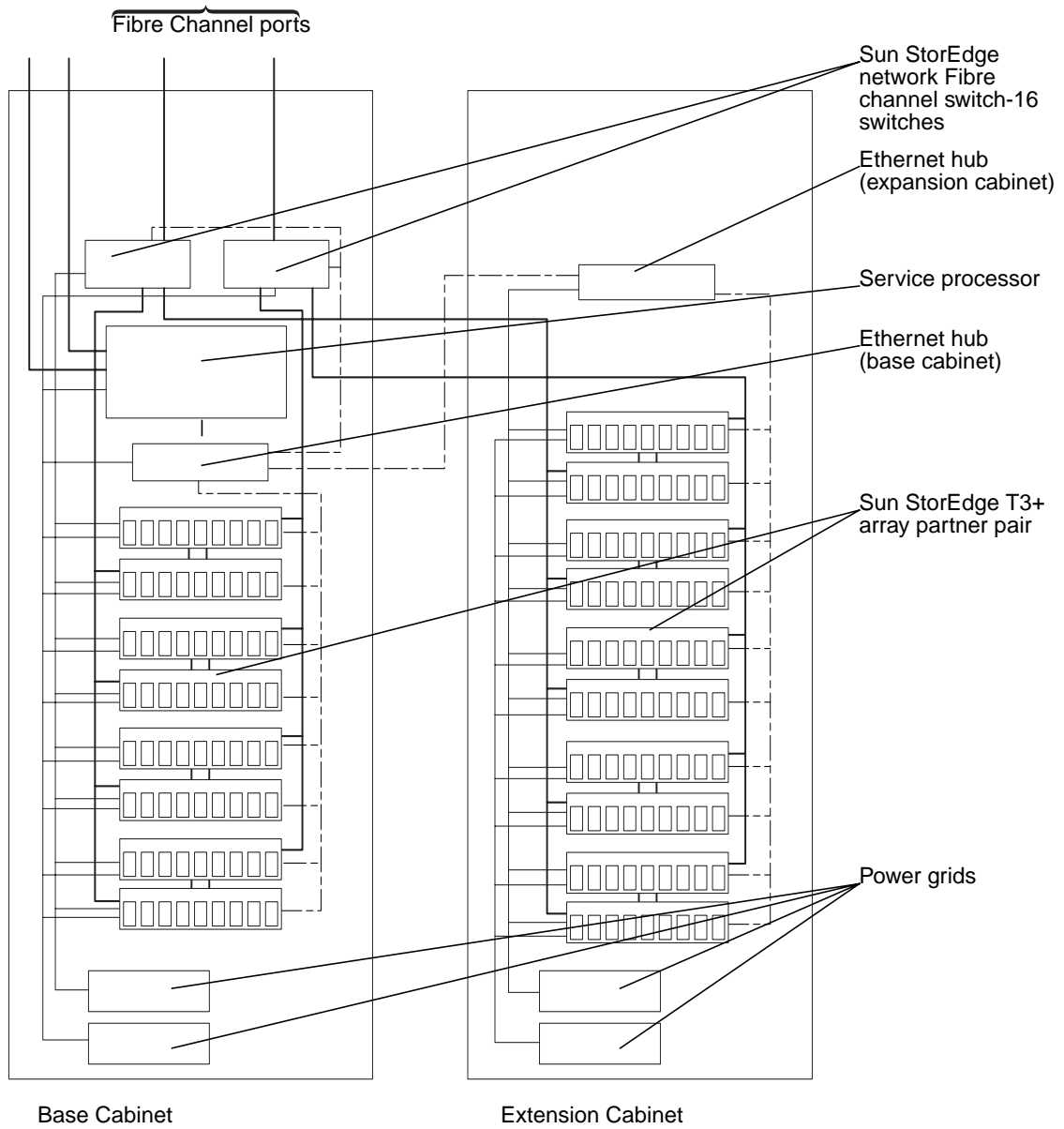

FIGURE 8-3 Sun StorEdge 3960 Storage System Cabling

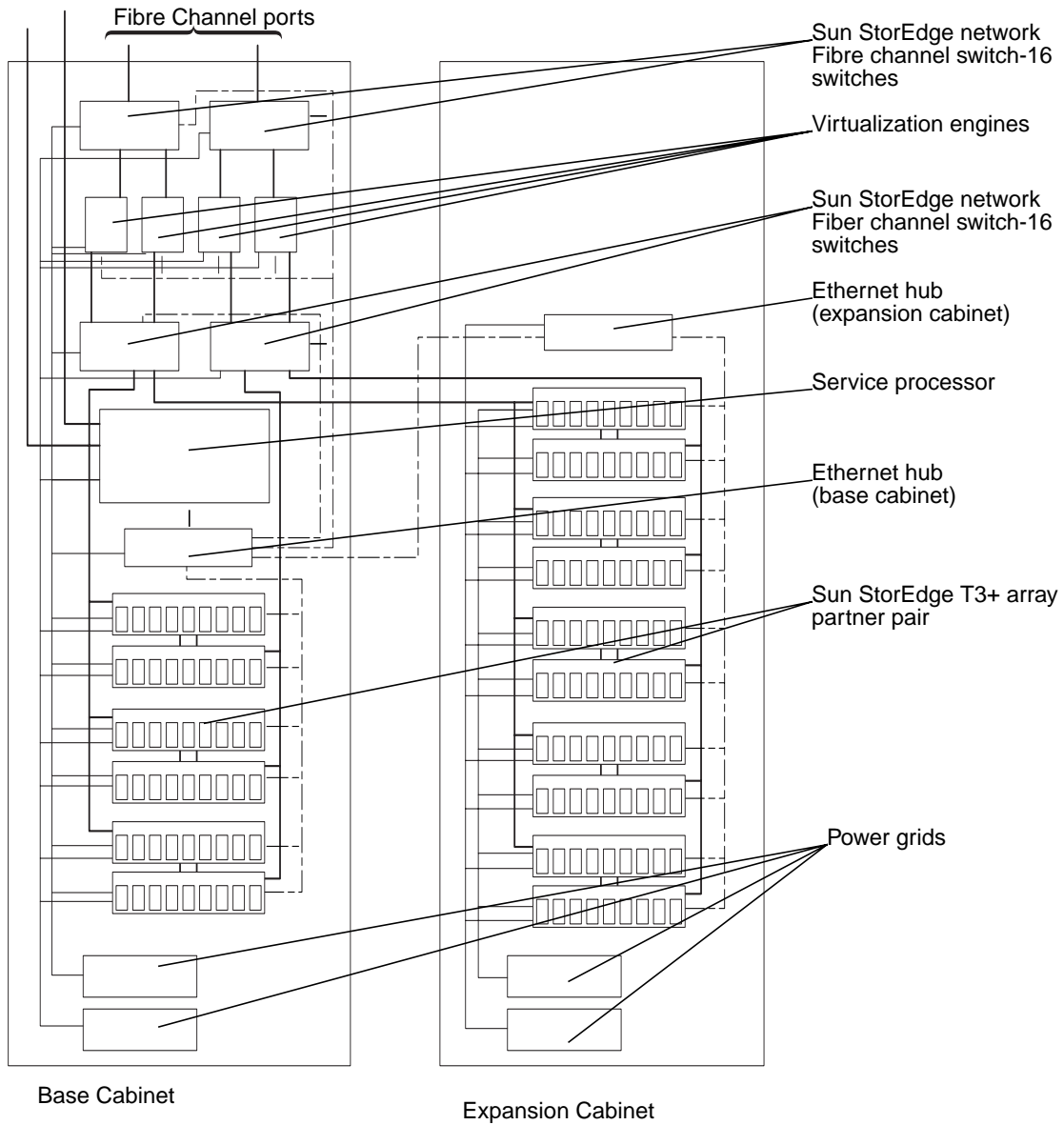

FIGURE 8-4 Sun StorEdge 6960 Storage System Cabling

8.3 Connecting the Sun StorEdge 3900SL, 6910SL or 6960SL Storage Systems to the Host

The Sun StorEdge 3900SL, 6910SL, or 6960SL storage systems do not contain the 8-port Fibre channel switches or 16-port Fibre channel switches inside the storage system cabinet for host connectivity. The storage system must be connected to the host through external Fibre Channel switches

The storage systems are configured as if the switches were contained in the storage system cabinet. However, the utilities that are used on the Sun StorEdge 3900 and 6900 series storage systems will not maintain the switches outside the storage system cabinet. Those switches must be configured and maintained by the utilities provided by the switch manufacturer.

8.4 Attaching a Sun StorEdge 3900 or 6900 Series Storage Systems to a LAN

There can be many considerations when connecting a Sun StorEdge 3900 or 6900 series storage system to the customer's LAN. These instructions assume:

- The Storage Automated Diagnostic Environment is configured properly and functioning.
- None of the system files on the Storage Service Processor have been altered since the Sun StorEdge 3900 or 6900 series storage system arrived.
- Sun trained personnel perform these steps and understand how Solaris communicates on a network.
- The customer is using the Network Information Service (NIS) naming service.

1. Type:

```
# /usr/sbin/sys-unconfig
```

- ### 2. Refer to the *Solaris 8 System Administration Collection* for detailed instructions about configuring your intranet.

Connecting to Servers Running the Solaris Operating Environment

Note – See www.sunsolve.sun.com and *Sun StorEdge 3900 and 6900 Series Release Notes* for the software requirements for the host.

This chapter contains the procedures for connecting servers running the Solaris operating environment to the Sun StorEdge 3900 and 6900 series storage system and tips about cascaded switch environments.

Solaris servers that connect to the Sun StorEdge 3900 and 6900 series storage system must be running the Solaris 8 10/01 operating environment or later.

This chapter contains the following sections:

- Section 9.1, “Setting Up a Solaris Server” on page 9-2
- Section 9.2, “Configuring the `ssd.conf` File” on page 9-5
- Section 9.3, “Configuring the Sun StorEdge Traffic Manager” on page 9-7
- Section 9.4, “Matching the Host WWN to the Device Channel and Creating SLIC Zones for LUN Masking” on page 9-8
- Section 9.4, “Matching the Host WWN to the Device Channel and Creating SLIC Zones for LUN Masking” on page 9-8
- Section 9.5, “Setting Up VERITAS Volume Manager Support” on page 9-19
- Section 9.6, “Mapping VLUNs to Devices” on page 9-21
- Section 9.7, “Setting Up Cascaded Switches on Sun StorEdge 6900 Series Storage System” on page 9-23

The following tools are required to perform the tasks in this chapter:

- Laptop or server terminal

9.1 Setting Up a Solaris Server

1. Install the Solaris 8 10/01 operating environment or later.
2. If the Solaris 8 10/01 operating environment is installed, install the Solaris 8 recommended patch cluster. If the Solaris 9 operating environment is installed, install the Solaris 9 recommended patch cluster.
3. Reboot the server.
4. Log in to the following URL, download the SUNWsan, SUNWcfpl, and SUNWcfplx packages, and install them. Also, download the *Sun StorEdge SAN 4.0 Release Installation Guide* for information about additional patches.

```
http://www.sun.com/storage/san
```

5. If the Solaris 8 10/01 operating environment is installed, install the following patches in the order shown. The version of the patches must be the version shown or later.
 - 111847-04
 - 110614-02
 - 108982-09
 - 108984-08
 - 109529-06
 - 111412-09
 - 111413-08
 - 111095-10
 - 111096-04
 - 111097-10
 - 111588-03
 - 111846-04
- a. If the Solaris 9 operating environment is installed, install the following patches in the order shown. The version of the patches must be the version shown or later.
 - 113039-01
 - 111847-04
 - 113040-02
 - 113041-01
 - 113042-02
 - 113043-01
 - 113044-01
6. Reboot the server.

Note – No error messages should appear during the reboot.

7. From the server, check the version of the Sun FC HBA drivers, using the following command:

```
# modinfo | grep -i qlc
46 1029ba3a 2d..... 1 qlc (SunFC Qlogic FCA v5.a-2-1.23)
#
```

You need to have at least the minimum version level of v5.a-2-1.23 for the Sun FC HBA drivers.

8. Determine the Sun FC HBA driver Fcode:

```
# luxadm qlgc_s_download
Found Path to 2 FC100/P, Devices
Opening Device: /devices/pci@a,2000/SUNW,qlc@2/fp@0,0:devctl
  Detected FCode Version:      ISP2200 FC-AL Host Adapter Driver: 1.13 01/03/05
Opening Device: /devices/pci@b,2000/SUNW,qlc@2/fp@0,0:devctl
  Detected FCode Version:      ISP2200 FC-AL Host Adapter Driver: 1.13 01/03/05
Complete
#
```

The revision level you must have for the FCode is 1.13. If you do not have the correct level, install patch 111853-01, which contains the 1.13 Sun FC HBA FCode and the instructions about how to update the FCode on the HBAs.

9. Using the instructions in Section 9.2, “Configuring the `ssd.conf` File” on page 9-5, verify the need to edit the `ssd.conf` file.
10. If you are using Sun StorEdge Traffic Manager (MPxIO), edit the `scsi_vhci.conf` file, using the instructions in Section 9.3, “Configuring the Sun StorEdge Traffic Manager” on page 9-7.
11. If you are using VERITAS Dynamic Multipathing (VxDMP), refer to the VERITAS documentation for installation instructions.
12. To clean up the classes of the listed devices, type:

```
# /usr/sbin/devfsadm -C
```

This command can take a few minutes to complete.

13. Reboot the server.

14. Type `/usr/sbin/cfgadm -la` to get a list of attached Fabric devices:

```
# /usr/sbin/cfgadm -la
wst4# cfgadm -la
Ap_Id                                     Type          Receptacle  Occupant    Condition
ac0:bank0                                 memory        connected   configured  ok
ac0:bank1                                 memory        empty       unconfigured unknown
c0::dsk/c0t6d0                            CD-ROM       connected   configured  unknown
c6                                         fc-fabric    connected   unconfigured unknown
c6::2b00006022002145                      disk         connected   unconfigured unknown
c6::2b00006022004185                      disk         connected   unconfigured unknown
c6::210000e08b04e70f                      unknown     connected   unconfigured unknown
...
```

15. For each Fabric device, run the following command:

```
# /usr/sbin/cfgadm -c configure cn
```

16. Install volume management software if you are using Solaris Volume Manager or VERITAS 3.2.

Note – Do not use the `metaset(1M)` feature of the Solaris Volume Manager with Sun StorEdge 6900 series systems if you are using Veritas 3.2. If you are using Veritas 3.2, you should specify Veritas Volume Manager.

Note – If you are using VERITAS 3.2, and the Solaris 8 10/01 operating environment, you must install patches 111904-04 (or later) and 111909-04 (or later).

17. Reboot the server.

18. Follow the instructions in Section 9.4.1, “Setting up a SLIC Zone for Each HBA and Creating and Masking VLUNs” on page 9-11.

19. Log in to the Storage Service Processor from the Solaris server and verify that you have the correct version of the SUNWsesp (Version 1.0.1.001) package installed.

See Chapter 5 for the procedures to log in to the Storage Service Processor.

To determine the level of the software image on the Storage Service Processor, enter the following command as root:

```
msp0: root# pkginfo -l SUNWsesp
  PKGINST: SUNWsesp
  NAME: Network service processor
  CATEGORY: Diagnostics
  ARCH: sparc
  VERSION: 1.0.1.001
  BASEDIR: /opt
  VENDOR: Sun Microsystems Computer Corporation
  DESC: Network service processor Specific Files
  PSTAMP: Built by bplom@memphis on 01/11/02 17:27:50
  INSTDATE: Jan 11 2002 19:12
  STATUS: completely installed
  FILES: 26 installed pathnames
         9 shared pathnames
         8 directories
         4 executables
         32 blocks used (approx)

msp0: root#
```

9.2 Configuring the `ssd.conf` File

On the server connected to the Sun StorEdge 6900 series, the `ssd(7D)` driver may require that properties are set in the `/kernel/drv/ssd.conf` file. If the server is running the Solaris 9 operating environment, no changes are required. If the server is running Solaris 8 10/01 operating environment, use the following two steps to determine if changes to the `ssd.conf` file are required.

- 1. Use the following example to check the host for the version of patch 109524. If the version is 109524-11 or later, do not edit the `ssd.conf` file. If the `ssd.conf` file contains the entries listed in Step 2, remove the entries.**

```
# showrev -p |grep 109524
Patch: 109524-09 Obsoletes: 111768-01 Requires: Incompatibles:
Packages: SUNWcsu, SUNWssad, SUNWssadx, SUNWcsxu, SUNWhea
```

2. If the version is 109524-10 or earlier, add the following entry into the `ssd.conf` file. For example:

```
#ident    "@(#)ssd.conf 1.9    99/07/29 SMI"

ssd-config-list="SUN    SESS01", "sess-data";
sess-data=1,0x1d,10,0,60,36,60;
```

Note – Use spaces between the SUN and SESS01, and a space after the comma.

The syntax for the entries in the `ssd.conf` file are as follows:

- The `ssd(7D)` driver looks for the property named `ssd-config-list`. The value of this property is a list of one or more duplets, where each duplet consists of two strings. The syntax is:

`ssd-config-list = "vid + pid" , "data-property-name" where:`

TABLE 9-1 `ssd-config-list` Property Parameter

Parameter	Description
<code>"vid + pid"</code>	The value returned in the device's inquiry data
<code>"data-property-name"</code>	The name of the property that contains the configuration values for the specified <code>vid + pid</code> .

- The second entry line contains the node specification. A semicolon is used to terminate a node specification. Individual elements listed within the specification are separated by commas.

`data-property-name = version , flags , propn , propn , . . . ; where:`

TABLE 9-2 `data-property-name` Node Specification Parameters

Parameter	Description
<code>data-property-name</code>	The name of the property that contains the configuration values for the specified <code>vid + pid</code> .
<code>version</code>	The version level.
<code>flags</code>	Contains a bit mask with a bit set for each property value that changed.
<code>propn</code>	Contains updated values for the node type.

9.3 Configuring the Sun StorEdge Traffic Manager

1. From the Solaris server, edit the `/kernel/drv/scsi_vhci.conf` file to globally enable MPxIO:

```
#
# Copyright (c) 2001 by Sun Microsystems, Inc.
# All rights reserved.
#
#pragma ident    "@(#)scsi_vhci.conf    1.2    01/07/12 SMI"
#
name="scsi_vhci" class="root";
#
# mpxio Global enable/disable configuration
# possible values are mpxio-disable="no" or mpxio-disable="yes"
#
mpxio-disable="no";
#
# Load Balancing global configuration
# possible values are load-balance="none" or load-balance="round-
robin"
#
load-balance="round-robin";
```

Make the following change:

- Change the `mpxio-disable` value to `no`.

2. Perform a reconfiguration reboot. For example:

```
# shutdown -y -i0
ok> boot -r
```

If you want to configure this on a per-channel or per-port basis, refer to the *Sun StorEdge Traffic Manager Software Installation and Configuration Guide* for additional information.

9.4 Matching the Host WWN to the Device Channel and Creating SLIC Zones for LUN Masking

1. From the Solaris server, enter the following script and name it `wnscript.sh`:

```
#!/bin/sh

for i in `cfgadm |grep fc-fabric|awk '{print $1}'`;do
    dev=`cfgadm -lv $i|grep devices|awk '{print $NF}'`
    wwn=`luxadm -e dump_map $dev |grep 'Host Bus'|awk '{print $4}'`
    echo "$i: $wwn"
done
```

The above script performs the following:

- Obtains the channel numbers for all the Fibre Channel HBAs running in Fabric mode, using the `cfgadm(1M)` command.
- Obtains the device name of each channel that it has discovered, using `cfgadm`.
- Obtains the WWN of that device, using the `luxadm(1M)` command.

2. Make the script executable. For example:

```
# chmod 755 wnscript.sh
```

3. From the Solaris server, type:

```
# wwn-script.sh
c4: 210000e08b042f80
c5: 210000e08b041d80
c6: 210000e08b043080
c7: 210000e08b042e80
c8: 210100e08b24e70f
c9: 210000e08b04e70f
c10: 210100e08b24aa55
c11: 210000e08b04aa55
#
```

If this fails to report an HBA WWN, you can run the following command on the Storage Service Processor to determine the HBA WWNs that are directly attached to the internal Sun StorEdge 6900 series Fibre Channel switch. For example:

```
# /opt/SUNWsecfg/bin/showswitch -s sw1a
...
*****
Name Server
*****

Port   Address   Type   PortWWN           Node WWN           FC-4 Types
-----
01     104000    N      2b0000602200418a  2a0000602200418a  SCSI_FCP
02     104100    N      210000e08b042e80  200000e08b042e80
03     104200    N      210000e08b04465c  200000e08b04465c
04     104300    N      210100e08b24aa55  200100e08b24aa55
...
#
```

The above output shows the virtualization engine WWN and the HBA WWNs.

4. Run the showvemap(1M) command on the Storage Service Processor to see the virtualization engine summary. For example:

```

sp0# /opt/SUNWsecfg/bin/showvemap -n v1 -f
*****
VIRTUALIZATION ENGINE SUMMARY

Initiator  UID                      VE Host  Online  Revision  Number of SLIC Zones
-----
I00001    2900006022004183  v1b     Yes    08.17     3
I00002    2900006022004185  v1a     Yes    08.17     1

*****
ZONE SUMMARY

Zone Name  HBA WWN                  HBA Name  Initiator  Online  Number of VLUNS
-----
padma_1    210100E08B2358F9  phba     I00001    Yes    2
zeol       210100E08B24AA55  alio1    I00001    Yes    0
zeeo2      210000E08B043080  alioo2   I00001    Yes    1
Undefined  210000E08B043654  Undefined I00001    Yes    0
Undefined  210000E08B0358F9  Undefined I00001    Yes    0
Undefined  210100E08B2480C0  Undefined I00001    Yes    0
Undefined  210100E08B247FC0  Undefined I00001    Yes    0
padma_2    210000E08B042E80  Undefined I00002    Yes    3
Undefined  210000E08B04E70F  Undefined I00002    Yes    0
Undefined  210100E08B243654  Undefined I00002    Yes    0
Undefined  210000E08B047FC0  Undefined I00002    Yes    0
Undefined  210000E08B0480C0  Undefined I00002    Yes    0

*****
#

```

Match the HBA WWN for the Undefined zone from the showvemap output with the channel/WWN pair from the output of the script on the host. Use this information to create a virtualization engine zone for the HBA for LUN masking operations.

Run the showvemap command for each virtualization engine pair. If no HBAs show up under the ZONE SUMMARY, run the savevemap(1M) command.

```

# /opt/SUNWsecfg/bin/savevemap -n [v1,v2]

```

The virtualization engine SLIC zones can now be created for LUN masking.

5. For the device channel, the WWN can be determined from the output in Step 3.

The virtualization engine should see the port WWN of the HBA.

6. Use this channel/WWN combination to create HBA aliases and SLIC zones on the Sun StorEdge 6900 series storage system.

Run the command `showvemap` on the Storage Service Processor. For example:

```
# /opt/SUNWsecfg/bin/showvemap -n [v1,v2] -f
```

9.4.1 Setting up a SLIC Zone for Each HBA and Creating and Masking VLUNs

1. Log in to the Storage Service Processor if not already logged on and use the following steps to set up alaodzinski SLIC zone for each HBA and create and mask VLUNs.

Choose one zone from each virtualization engine initiator (a total of two zones) associated with the same data host for the LUN masking operation. This ensures the required two paths to each VLUN on the data host.

See Chapter 5 for the procedures to log into the Storage Service Processor.

2. While logged in to the Storage Service Processor, issue the following command:

```
# /opt/SUNWsecfg/bin/runsecfg
```

Select “Virtualization Engine Configuration Utility” from the main menu and the following menu is displayed:

3. Creating Multiple Zones.

```
...
VIRTUALIZATION ENGINE MAIN MENU

1) Manage VLUNs
2) Manage Virtualization Engine Zones
3) Manage Configuration Files
4) Manage Virtualization Engine Hosts
5) MP Drive Failback Support
6) Help
7) Return
Select option above:> 2
```

4. Selecting option 2 produces the following menus.

```
...
MANAGE ZONES MENU

1) Create Virtualization Engine Zones
2) Add Components to Virtualization Engine Zone
3) Delete Components from Virtualization Engine Zone
4) Remove Virtualization Engine Zone
5) View Virtualization Engine Map
6) Help
7) Return
Select zone option above:> 1

Do you want to create single of multiple zone(s) [s|m] : m

Do you want to create zones on V1, I00001 [y|n] : y

AVAILABLE WWN NUMBERS (v1 , I00001)

1) 210000E08B04AA55
2) 210100E08B2358F9
3) 210000E08B043654
4) 210000E08B043080
5) 210000E08B0358F9
6) 210100E08B2480C0
7) 210100E08B247FC0
8) Return
Select option above:> 1

Please enter the zone name (Recommendation : host_channelID ,
(Note : There is a max length of 15 chars for the zone name) : accts

Do you want to specify an alias name for the HBA?
(Note : alias name - is the user-defined HBA alias for the
associated WWN channel, if not specified, the zone name will be
used. Unique names should be used when multiple HBAs are in a
single zone, as in clusters). [y|n] : y

Please enter the HBA alias name (Note : There is a max length of
15 chars for the alias name) : ally1

Do you want to create more zones on v1, I00001 [y|n] : n

Do you want to create zones on v1, I0002 [y|n] : y
```

Step 4 continued.

```
AVAILABLE WWN NUMBERS (v1 , I00002)

1) 210000E08B042F80
2) 210000E08B04E70F
3) 210100E08B243654
4) 210000E08B047FC0
5) 210000E08B0480C0
6) Return
Select option above:> 1

Please enter the zone name (Recommendation : host_channelID , (Note
: There is a max length of 15 chars for the zone name): csdata

Do you want to specify an alias name for the HBA?
(Note : alias name - is the user-defined HBA alias for the
associated WWN channel, if not specified, the zone name will be
used. Unique names should be used when multiple HBAs are in a
single zone, as in clusters). [y|n] : n

Do you want to create more zones on v1, I00002 [y|n] : n

Do you want to create zones on v2, I00001 [y|n] : y

AVAILABLE WWN NUMBERS (v2 , I00001)

1) 210100E08B243654
2) 210000E08B047FC0
3) 210000E08B0480C0
4) Return
Select option above:> 1

Please enter the zone name (Recommendation : host_channelID , Note
: There is a max length of 15 chars for the zone name): accts_alt

Do you want to specify an alias name for the HBA?
(note : alias name - is the user-defined HBA alias for the
associated WWN channel, if not specified, the zone name will be
used. Unique names should be used when multiple HBAs are in a
single zone, as in clusters). [y|n] : n

Do you want to create more zones on v2, I00001 [y|n] : n

Do you want to create zones on v2, I00002 [y|n] : y
```

Step 4 continued.

```
AVAILABLE WWN NUMBERS (v2 , I00002)

1) 210000E08B043654
2) 210000E08B0358F9
3) 210100E08B2480C0
4) 210100E08B247FC0
5)Return
Select option above:> 1

Please enter the zone name (Recommendation : host_channelID . Note
: There is a max length of 15 chars for the zone name): csdata_alt

Do you want to specify an alias name for the HBA?
(note : alias name - is the user-defined HBA alias for the
associated WWN channel, if not specified, the zone name will be
used. Unique names should be used when multiple HBAs are in a
single zone, as in clusters). [y|n] : n

Do you want to create more zones on v2, I00002 [y|n] : n
Creating multiple virtualization engine zones .....

HBA alias ally1 : created successfully
zone accts : created successfully on v1 initiator I00001.
HBA alias csdata : created successfully.
zone csdata : created successfully on v1 initiator I00002.
HBA alias accts_alt : created successfully
zone accts_alt : created successfully on v2 initiator I00001.
HBA alias csdata_alt : created successfully.
zone csdata_alt : created successfully on v2 initiator I00002.

Finished creating multiple virtualization engine zones .....

Successfully saved map for virtualization engine pair v1
Successfully saved map for virtualization engine pair v2
```

5. Creating multiple VLUNs (with zones and without zones).

```
VIRTUALIZATION ENGINE MAIN MENU
1) Manage VLUNs
2) Manage Virtualization Engine Zones
3) Manage Configuration Files
4) Manage Virtualization Engine Hosts
5) MP Drive Failback Support
6) Help
7) Return
Select option above:> 1

MANAGE VLUNs MENU

1) Create VLUNs
2) Remove VLUNs
3) View Virtualization Engine Map
4) Help
5) Return
Select VLUN option above:> 1

Do you want to create VLUNs in a single or multiple diskpools [s|m]
: m

Do you want to create VLUNs on v1 : [y|n] y

DISK POOLS FOR v1 (free space)

1) t3b00(102GB)
2) t3b01(102GB)
3) t3b02(272GB)
4) t3b03(272GB)
5) t3b20(102GB)
6) t3b21(102GB)
7) t3b22(272GB)
8) t3b23(272GB)
9) Return
Select option above:> 4

Note : Creation of each VLUN can take up to 1 minute.

Please enter the number of VLUN(s) that need to be created: 10

Please enter the size in GB for each VLUN (1 GB increments): 1
```

Step 5 continued.

```
Do you want to specify the zones? [y|n]: n

Do you want to specify a name for the VLUN? [y|n]: y

Please enter a name for the VLUN (There is a max length of 10 chars
including a unique ID prefix that will be added automatically): pad

Do you want to create more VLUNs on virtualization engine v1 :
[y|n] n

Do you want to create VLUNs on v2 : [y|n] y

DISK POOLS FOR v2 (free space)

1) t3b10(417GB)
2) teb11(457GB)
3) Return
Select option above:> 2

Note : Creation of each VLUN can take up to 1 minute.

Please enter the number of VLUN(s) that need to be created: 8

Please enter the size of GB for each VLUN (1 GB increments): 2

Do you want to specify the zones? [y|n]: y

AVAILABLE ZONES FOR (I00001, I00002)

1) accts(I00001)
2) csdata(I00001)
3) corp_alt(I00002)
4) finance_alt(I00002)
5) accts_alt(I00002)
6) csdata_alt(I00002)
7) Return
Enter zone numbers from the list above (multiple entries are space
separated):. 1 2 6

INFO: VLUNs will be added to the zone(s) accts, csdata, csdata_alt.
Enter y to continue or n to select zones again. [y|n] y

Do you want to specify a name for the VLUN? [y|n] n
```

Step 5 continued.

```
Do you want to create more VLUNs on virtualization engine v2 : [y|n] n
```

```
This functionality requires a check that T3+ physical LUN is mounted.
```

```
Please enter the Sun StorEdge T3+ array password: password
```

```
Creating multiple VLUN(s)
```

```
Checking that associated T3+ physical LUN is mounted...
```

```
VLUN T16384 : created Successfully on disk pool t3b03 with name lpad.
```

```
VLUN T16385 : created successfully on disk pool t3b03 with name 2pad.
```

```
VLUN T16386 : created successfully on disk pool t3b03 with name 3pad.
```

```
VLUN T16387 : Created successfully on disk pool t3b03 with name 4pad.
```

```
VLUN Y16388 : created successfully on disk pool t3b03 with name 5pad.
```

```
VLUN Y16389 : created successfully on disk pool t3b03 with name 6pad.
```

```
VLUN Y16390 : created successfully on disk pool t3b03 with name 7pad.
```

```
VLUN Y16391 : created successfully on disk pool t3b03 with name 8pad.
```

```
VLUN Y16392 : created successfully on disk pool t3b03 with name 9pad.
```

```
VLUN Y16393 : created successfully on disk pool t3b03 with name 10pad.
```

```
WARNING: VLUNs just created were not added to any zones.
```

```
This should be done to avoid data corruption. Refer to addtovezone  
command.
```

```
WARNING: Adding VLUNs to more than two zones must be carefully managed  
to avoid data corruption.
```

```
checking that associated T3+ physical LUN is mounted...
```

```
VLUN T16392 : created successfully on disk pool t3b11.
```

```
VLUN T16393 : created successfully on disk pool t3b11.
```

```
VLUN T16394 : created successfully on disk pool t3b11.
```

```
VLUN T16395 : created successfully on disk pool t3b11.
```

```
VLUN T16396 : created successfully on disk pool t3b11.
```

```
VLUN T16397 : created successfully on disk pool t3b11.
```

```
VLUN T16398 : created successfully on disk pool t3b11.
```

```
VLUN T16399 : created successfully on disk pool t3b11.
```

```
VLUN T16392 T16393 T16394 T16395 T16396 T16397 T16398 T16399 : added  
successfully to zone accts.
```

```
VLUN T16392 T16393 T16394 T16395 T16396 T16397 T16398 T16399 : added  
successfully to zone csdata.
```

Step 5 continued.

```
VLUN T16392 T16393 T16394 T16395 T16396 T16397 T16398 T16399 :  
added successfully to zone csdata_alt.  
  
Finished creating multiple VLUN(s) .....  
  
Successfully saved map for virtualization engine pair v1  
Successfully saved map for virtualization engine pair v2
```

9.4.2 Setting Up Newly Created VLUNs

1. **Configure the drive type using the `format(1M)` command.**

Note – Do not specify the drive type, let `format(1M)` command auto configure the drive type.

2. **Label the drive using the `format(1M)` command.**

3. Repartition the drive to meet your needs.

The following script uses the `format(1M)` command to auto configure the drive type and label the drive:

```
#!/bin/sh
channel=$1
target=$2
if [ ! -n "${channel}" ]; then
    echo "usage:$0 channel [target]\n"
    exit 1
fi

for dev in /dev/rdisk/${channel}${target}*s2 ; do
    if [ -c ${dev} ]; then
        dsk=`echo ${dev}|sed -e 's/rdisk/dsk/' -e 's/d[0-9]*s2//`"
        grep ${dsk} /etc/vfstab > /dev/null
        INUSE1=$?
        grep ${dsk} /etc/mnttab > /dev/null
        INUSE2=$?
        if [ ${INUSE1} -eq 0 OR ${INUSE2} -eq 0 ]; then
            echo "Don't try to format/label channel $channel target $target"
            exit 1
        else
            format ${dev} > /dev/null 2>&1 <<END
            type
            0
            label
            yes
            quit
            END
            if [ $? -eq 0 ]; then
                echo "Found ${dev}"
            fi
        fi
    fi
done
```

9.5 Setting Up VERITAS Volume Manager Support

The following procedures are required to support the VERITAS Volume Manager on the Sun StorEdge 6900 series storage systems:

- VERITAS Volume Manager 3.2 Patch level 1 (minimum), which includes patch 111909-04 and 111904-04

Perform the following steps:

1. Follow the typical procedure to setup and install all hardware and software, including all needed patches.
2. Install the VERITAS Volume Manager 3.2 CD.
3. Install the VERITAS Volume Manager 3.2 Patch 01.
4. Add VERITAS Device Discovery Layer support for Sun StorEdge 6900 series storage system. For example:

```
# /usr/sbin/vxddladm addjbod vid=SUN pid=SESS01
```

5. Use the vxddladm(1M) command to verify the virtualization engine is supported. For example:

```
# /usr/sbin/vxddladm listjbod
VID    PID      Opcode  Page Code  Page Offset  SNO length
=====
SUN    SESS01   18      -1          36           12
```

6. Run the vxinstall(1M) command.

Note – The vxddladm command must be run before you execute the vxinstall command.

7. Reboot the system.
8. Verify that the devices are now working and multipathed. Sun StorEdge 6900 series devices are listed under the enclosure name Disk; the device name takes the form Disk_nn. Devices under Disk_nn are multipathed disks. For example:

```
# /usr/sbin/vxdmpadm listenclosure all
ENCLR_NAME      ENCLR_TYPE      ENCLR_SNO      STATUS
=====
OTHER_DISKS     OTHER_DISKS     OTHER_DISKS     CONNECTED
Disk            Disk            DISKS           CONNECTED
```

9. Verify that disk and multipathing paths are recognized by using the `vxdmpadm` commands. For example:

```
# /usr/sbin/vxdisk list
DEVICE      TYPE      DISK      GROUP      STATUS
Disk_0     sliced   disk04    rootdg     online
Disk_1     sliced   disk05    rootdg     online
Disk_2     sliced   disk06    rootdg     online
Disk_3     sliced   disk07    rootdg     online
Disk_4     sliced   disk08    rootdg     online
Disk_5     sliced   disk09    rootdg     online
Disk_6     sliced   disk10    rootdg     online
```

```
# /usr/opt/SUNWvxdm/vxdmpadm getdmpnode enclosure=Disk
NAME        STATE      ENCLR-TYPE  PATHS  ENBL  DSBL  ENCLR-NAME
=====
Disk_0     ENABLED   Disk        2      2      0     Disk
Disk_1     ENABLED   Disk        2      2      0     Disk
Disk_2     ENABLED   Disk        2      2      0     Disk
Disk_3     ENABLED   Disk        2      2      0     Disk
Disk_4     ENABLED   Disk        2      2      0     Disk
Disk_5     ENABLED   Disk        2      2      0     Disk
Disk_6     ENABLED   Disk        2      2      0     Disk
...
#
```

9.6 Mapping VLUNs to Devices

If you are running Sun StorEdge Traffic Manager (MPxIO) or DMP, you may need to map devices back to a specific VLUN on the Sun StorEdge 6900 series storage system. These instructions tell you how to determine the device name depending on whether you are using Sun StorEdge Traffic Manager or DMP.

To determine the device numbers for Sun StorEdge Traffic Manager:

1. Obtain the VLUN serial number, which is the second 16 characters in the target ID. For example:

```
# format
...
AVAILABLE DISK SELECTIONS:
  0. c0t0d0 <SUN18G cyl 7506 alt 2 hd 19 sec 248> OSdsk28
    /ssm@0,0/pci@18,700000/pci@1/SUNW,isptwo@4/sd@0,0
  1. c9t2900006022004196625733613030446Ad0 <SUN-SESS01-080C cyl 51198 alt
  2 hd 16 sec 128>
    /scsi_vhci/ssd@g2900006022004196625733613030446a
  2. c9t29000060220041966257336130304473d0 <SUN-SESS01-080C cyl 51198 alt
  2 hd 16 sec 128>
...

```

2. Match the VLUN serial number (for example, 625733613030446a) to the listing from the virtualization engine map on the Storage Service Processor. To obtain the virtualization engine map, enter the following command:

```
# /opt/SUNWsecfg/bin/showvemap -n v1 -f
Diskpool  VLUN Serial      MP Drive  VLUN    VLUN      Size    Slic Zones
          Number        Target   Target   Name      GB
-----
t3b00    6257336130304473    T49152   T16384   1t3b00    50.0    zonea,zoneb
t3b00    625733613030446A    T49152   T16385   2t3b00    50.0    zonea,zoneb
#

```

3. Match the VLUN Target number, from Step 2, with the serial number from Step 1.

9.6.1 Determining the Device Numbers for DMP

1. Obtain the VLUN serial number from the `format(1M)` command. For example:

```
# format -e
...
AVAILABLE DISK SELECTIONS:
    0. c0t0d0 <SUN18G cyl 7506 alt 2 hd 19 sec 248> OSdsk28
       /ssm@0,0/pci@18,700000/pci@1/SUNW,isptwo@4/sd@0,0
    1. c9t2B00006022004196d0 <SUN-SESS01-080C cyl 51198 alt 2
hd 16 sec 128>
       /scsi_vhci/ssd@g2900006022004196
    2. c9t2B00006022004196d0 <SUN-SESS01-080C cyl 51198 alt 2
hd 16 sec 128>
...

```

2. While using the `format(1M)` command, select a device and enter the `scsi` mode. For example:

```
# format> scsi
scsi> inquiry

Inquiry:
 00 00 03 12 2b 00 00 02 53 55 4e 20 20 20 20 20    ....+...SUN
 53 45 53 53 30 31 20 20 20 20 20 20 20 20 20 20    SESS01
 30 38 30 43 62 57 33 61 30 30 44 73 30 30 30      080CbW30003K000
...

```

The serial number (for example, 6257336130304473) is returned by the `inquiry` command. The two devices that have the matching serial number are the redundant paths to the same VLUNs.

9.7 Setting Up Cascaded Switches on Sun StorEdge 6900 Series Storage System

These steps must be performed on all Sun StorEdge 6900 series storage systems that reside in the same Storage Area Network (SAN) environment.

1. **Override the default chassis identifications for every additional Sun StorEdge 6900 series storage system if you have more than one. For example:**

```
# setupswitch -s switch_name -i chassis_id -v
```

The *switch-name* is the name defined in the `/etc/hosts` file. The *chassis-id* is a number in the range 1 to 63. The defaults are `sw1a` (1), `sw1b` (2), `sw2a` (3), `sw2b` (4).

The following commands would be run on a second Sun StorEdge 6900 series storage system in the SAN environment:

```
# setupswitch -s sw1a -i 5 -v
# setupswitch -s sw1b -i 6 -v
# setupswitch -s sw2a -i 7 -v
# setupswitch -s sw2b -i 8 -v
```

2. **If the cascaded switch has a hard zone of 2, modify the hard zone front-end switches to correspond to the associated hard zone identification on the cascaded switch in the SAN to which it is connected. For example:**

```
# setupswitch -s switch_name -z hardzone_id -v
```

The *switch-name* is the name defined in the `/etc/hosts` file. The *zone-id* overrides the default hard zone number on the front end switch. This is useful for SAN environments with cascaded switches and existing zones. The Sun StorEdge 6910 storage system range is one to eight. The Sun StorEdge 6960 storage system range is 1 to 16. The default hard zone number for both is one. This command is valid only on Sun StorEdge 6900 series storage system switches `sw1a` and `sw1b`.

The commands in the following example would be executed on front-end switches of Sun StorEdge 6900 series storage systems in a SAN environment, where the connection to a cascaded switch is in a preexisting hard zone 2:

```
# setupswitch -s sw1a -z 2 -v
# setupswitch -s sw1b -z 2 -v
```

3. **Make modifications to the cascaded switch that is outside the Sun StorEdge 6900 series storage system.**

You must ensure the associated ports are in the same hard zone ID as that of the associated Sun StorEdge 6900 series storage system and ensure its chassis ID is unique. These steps must be performed using the SANSurfer graphical user interface (GUI).

Connecting to Servers Running the Microsoft Windows NT Operating Environment

Note – See www.sunsolve.sun.com and *Sun StorEdge 3900 and 6900 Series 1.1 Release Notes* for the software requirements for the host.

This chapter contains the instructions for the software used to connect servers running Microsoft Windows NT to the Sun StorEdge 3900 and 6900 series storage system.

Chapter 8 describes how to connect the server and Sun StorEdge 3900 and 6900 series storage system.

This chapter contains the following sections:

- Section 10.1, “Connecting a Sun StorEdge 3900 Series Storage System to a Microsoft Windows NT Server” on page 10-2
- Section 10.2, “Connecting a Sun StorEdge 6900 Series Storage System to a Microsoft Windows NT Server” on page 10-3
- Section 10.4, “Setting Up Newly Created VLUNs” on page 10-7

The following tools are required to perform the tasks in this chapter:

- Laptop or server terminal

10.1 Connecting a Sun StorEdge 3900 Series Storage System to a Microsoft Windows NT Server

The Sun StorEdge 3900 series supports Microsoft Windows NT 4.0, Service Pack 6 or greater in either single-path or dual-path configurations. Dual-path configurations use the Sun StorEdge Traffic manager 2.0 for Microsoft Windows NT.

The important rules for setting up Microsoft Windows NT servers for a Sun StorEdge 3900 series storage system are:

- Each Microsoft Windows NT server and the associated Sun StorEdge T3+ array partner groups must be in a dedicated Hard Zone that is in SL mode.
- A maximum of one Microsoft Windows NT server with one initiator is allowed in this SL mode Hard Zone.
- The dedicated Hard Zone must operate completely in SL mode. That means the Sun StorEdge T3+ arrays and host ports must be set to SL mode.

1. Set up Sun multipath failover driver for Microsoft Windows NT.

If you are going to use dual path instead of single path, you must complete this step. See the *Sun StorEdge Traffic Manager 2.0 for Windows NT User's Guide* for detailed instructions about setting up the device driver on the server.

2. Determine the level of the SUNWsecfg. For example:

```
# pkginfo -l SUNWsecfg
```

If the SUNWsecfg package level is at baseline 1.13 or greater, use the following command to reconfigure the switches. You must run this command to change to SL mode on each Sun StorEdge T3+ array that is going to be connected to a Microsoft Windows NT server. For example:

```
# cd /opt/SUNWsecfg/bin/setswitchsl -n t3name -s on
```

3. Connect the Microsoft Windows NT server to the available ports.

4. Reboot the Microsoft Windows NT server.

The reboot must be done to make the recently configured LUNs visible to the Disk Administrator.

10.2 Connecting a Sun StorEdge 6900 Series Storage System to a Microsoft Windows NT Server

The Sun StorEdge 6900 series storage system supports Microsoft Windows NT Enterprise Edition 4.0, Service Pack 6 or greater in single-path and dual path configurations. The Sun StorEdge 6900 series storage system requires a Fabric connection to the Sun StorEdge Network FC switches.

1. **Ensure your host bus adapters (HBAs) are operating in Fabric mode and obtain the World Wide Name (WWN) for each HBA.**

The supported HBAs for the Microsoft Windows NT platform is the Emulex LP8000. To obtain the WWNs for any of these HBAs, use the tools provided by the manufacturer or from the card's BIOS.

- a. **For the Emulex HBA, use the LightPulse (`lputilnt.exe`) provided by Emulex. Select the Configuration Data and Region World Wide Name to obtain the WWN information. Alternatively, on the Emulex HBA, you can enter the card's BIOS when the Microsoft Windows NT system is booting. From there, the WWN information can be obtained.**

You can also obtain the HBA WWN by running the following command on the Storage Service Processor to determine the HBA WWNs that are directly attached to the internal Sun StorEdge 6900 series Fibre Channel switch. For example:

```
# /opt/SUNWsecfg/bin/showswitch -s sw1a
...
*****
Name Server
*****

Port   Address   Type   PortWWN           Node WWN           FC-4 Types
----   -
01     104000    N      2b0000602200418a  2a0000602200418a  SCSI_FCP
02     104100    N      210000e08b042e80  200000e08b042e80
03     104200    N      210000e08b04465c  200000e08b04465c
04     104300    N      210100e08b24aa55  200100e08b24aa55
...
#
```

The output above shows the virtualization engine WWN and the HBA WWNs.

2. Run the showvemap(1M) command on the Storage Service Processor to see the virtualization engine summary. For example:

```

sp0# /opt/SUNWsecfg/bin/showvemap -n v1 -f
*****
VIRTUALIZATION ENGINE SUMMARY

Initiator  UID                      VE Host  Online  Revision  Number of SLIC Zones
-----
I00001    2900006022004183  v1b     Yes    08.17    3
I00002    2900006022004185  v1a     Yes    08.17    1

*****
ZONE SUMMARY

Zone Name  HBA WWN                  HBA Name  Initiator  Online  Number of VLUNS
-----
padma_1    210100E08B2358F9  phba     I00001    Yes    2
zeol       210100E08B24AA55  alio1    I00001    Yes    0
zeeo2     210000E08B043080  alioo2   I00001    Yes    1
Undefined  210000E08B043654  Undefined I00001    Yes    0
Undefined  210000E08B0358F9  Undefined I00001    Yes    0
Undefined  210100E08B2480C0  Undefined I00001    Yes    0
Undefined  210100E08B247FC0  Undefined I00001    Yes    0
padma_2    210000E08B042E80  Undefined I00002    Yes    3
Undefined  210000E08B04E70F  Undefined I00002    Yes    0
Undefined  210100E08B243654  Undefined I00002    Yes    0
Undefined  210000E08B047FC0  Undefined I00002    Yes    0
Undefined  210000E08B0480C0  Undefined I00002    Yes    0

*****
#

```

Match the HBA WWN for the Undefined zone from the showvemap output with the channel/WWN pair from the output of the script on the host. Use this information to create a virtualization engine zone for the HBA for LUN masking operations.

Run the showvemap command for each virtualization engine pair. If no HBAs show up under the ZONE SUMMARY, run the savevemap(1M) command.

```

# /opt/SUNWsecfg/bin/savevemap -n [v1,v2]

```

The virtualization engine SLIC zones can now be created for LUN masking.

3. For the device channel, the WWN can be determined from the output in Step 1.

The virtualization engine should see the Port WWN of the HBA.

4. Use this channel/WWN combination to create HBA aliases and SLIC zones on the Sun StorEdge 6900 series.

Run the command `showvemap` on the Storage Service Processor to obtain information. For example:

```
# /opt/SUNWsecfg/bin/showvemap -n [v1,v2] -f
```

5. Run the `runsecfg(1M)` command to create HBA aliases and SLIC zones. For example:

```
# /opt/SUNWsecfg/bin/runsecfg
```

6. Select the Virtualization Engine Configuration Utility option and then the Manage Virtualization Engine Zones option to set up a SLIC zone for each HBA.

Note – This is only a single zone, not a dual path with two zones.

10.3 Creating VLUNs on the Sun StorEdge 6900 Series Storage System for Microsoft Windows NT Server

Note – You could create VLUNs through the virtualization Engine Configuration Utility option by issuing the `/opt/SUNWsecfg/bin/runsecfg` command on the Storage Service Processor. See Chapter 5 for information about logging into the Storage Service Processor or you could follow this command line procedure.

1. Get the virtualization engine pair name, using the `listvemap(1M)` command. For example:

```
# /opt/SUNWsecfg/bin/listvemap -r
v1
#
```

If no virtualization engine names are returned, either the virtualization engine is not functioning or a configuration process is already running.

2. Get the name of the Sun StorEdge T3+ array disk pool, using the `listvemap(1M)` command. For example:

```
# /opt/SUNWsecfg/bin/listvemap -d -n v1
t3b00 t3b01
#
```

In this example, the disk pool name would be `t3b00`.

3. Get the primary zone name, using the `listvemap` command. For example:

```
# /opt/SUNWsecfg/bin/listvemap -z -n v1 -c I00001
labsys_c1
#
```

4. Create the Microsoft Windows NT VLUNs, using the `createvlun(1M)` command and only specify a single zone.

The following example entry creates five VLUNs that are 10 Gbytes each for use with Microsoft Windows NT. The descriptive tag suffix is `ntvlun`.

```
# /opt/SUNWsecfg/bin/createvlun -n v1 -d t3b00 -l 10 -c 5 -v ntvlnun -V -z labsys_c1
VLUN T16384 : Created successfully in diskpool t3b00 with name 1ntvlun
VLUN T16385 : Created successfully in diskpool t3b00 with name 2ntvlun
VLUN T16386 : Created successfully in diskpool t3b00 with name 3ntvlun
VLUN T16387 : Created successfully in diskpool t3b00 with name 4ntvlun
VLUN T16388 : Created successfully in diskpool t3b00 with name 5ntvlun
VLUN T16384 T16385 T16386 T16387 T16388 added successfully to zone z
labsys_c1
#
```



Caution – If you are changing other VLUN information using the `runsecfg` menu interface or the Storage Automated Diagnostic Environment GUI interface, these VLUNs will still show up as “available.” To add to a second zone (since two paths to allow for failover are recommended), you must keep track of these Microsoft Windows NT VLUNs that have already been added into a single zone (that is, `showvemap -n v1 -f`); adding them into a second zone could cause data corruption problems.

10.4 Setting Up Newly Created VLUNs

1. **Configure and partition disks, using the Disk Administrator for Microsoft Windows NT.**

Refer to the Microsoft Windows NT documentation for details.

Connecting to Servers Running the Microsoft Windows 2000 Operating Environment

Note – See www.sunsolve.sun.com and *Sun StorEdge 3900 and 6900 Series 1.1 Release Notes* for the software requirements for the host.

This chapter contains the software instructions for connecting servers running Microsoft Windows 2000 to the Sun StorEdge 3900 and 6900 series storage systems.

See Chapter 8 for a description of how to connect the server and Sun StorEdge 3900 and 6900 series storage system.

This chapter contains the following sections:

- Section 11.1, “Connecting a Sun StorEdge 3900 Series Storage System to a Microsoft Windows 2000 Server” on page 11-2
- Section 11.2, “Connecting a Sun StorEdge 6900 Series Storage System to a Microsoft Windows 2000 Server” on page 11-2
- Section 11.3, “Creating VLUNs on the Sun StorEdge 6900 Series Storage System for Microsoft Windows 2000” on page 11-5
- Section 11.4, “Setting Up Newly Created VLUNs” on page 11-7

The following tools are required to perform the tasks in this chapter:

- Laptop or server terminal

11.1 Connecting a Sun StorEdge 3900 Series Storage System to a Microsoft Windows 2000 Server

The Sun StorEdge 3900 series storage system supports Microsoft Windows 2000 Server and Microsoft Windows 2000 Advanced Server, Service Pack 2 or greater in dual path configurations using Sun StorEdge Traffic Manager 2.0 failover drivers for Microsoft Windows 2000.

The important rules for setting up Microsoft Windows 2000 servers to a Sun StorEdge 3900 series storage systems are:

- Each Microsoft Windows 2000 server and the associated Sun StorEdge T3+ array partner groups must be in a dedicated Hard Zone.
- There is a maximum of one Microsoft Windows 2000 server with one initiator allowed in this SL mode Hard Zone.

11.2 Connecting a Sun StorEdge 6900 Series Storage System to a Microsoft Windows 2000 Server

The Sun StorEdge 6900 series storage system supports Microsoft Windows 2000 server attachments in single-path and dual-path configurations. The Sun StorEdge 6900 series storage system requires a Fabric connection to the Sun StorEdge Network Fibre Channel switches.

1. **Ensure your host bus adapters (HBAs) are operating in Fabric mode and obtain the World Wide Number (WWN) for each HBA.**

The supported HBAs for the Windows 2000 platforms are the Emulex LP8000. To obtain the WWNs for any of these HBAs, use the tools provided by the manufacturer or from the card's BIOS.

- a. **For the Emulex HBA, use the LightPulse (`lputilnt.exe`) provided by Emulex. Select the Configuration Data and Region World Wide Name to obtain the WWN information. Alternatively, on the Emulex HBA, you can enter the card's BIOS when the Microsoft Windows 2000 system is booting. From there, the WWN information can be obtained.**

You can also obtain the HBA WWN by running the following command on the Storage Service Processor to determine the HBA WWNs that are directly attached to the internal Sun StorEdge 6900 series storage system Fibre Channel switch. For example:

```
# /opt/SUNWsecfg/bin/showswitch -s sw1a
...
*****
Name Server
*****

Port  Address  Type  PortWWN          Node WWN          FC-4 Types
----  -
01    104000    N     2b0000602200418a  2a0000602200418a  SCSI_FCP
02    104100    N     210000e08b042e80  200000e08b042e80
03    104200    N     210000e08b04465c  200000e08b04465c
04    104300    N     210100e08b24aa55  200100e08b24aa55
...
#
```

The output above shows the virtualization engine WWN and the HBA WWNs.

2. Run the showvemap(1M) command on the Storage Service Processor to see the virtualization engine summary. For example:

```

sp0# /opt/SUNWsecfg/bin/showvemap -n v1 -f
*****
VIRTUALIZATION ENGINE SUMMARY

Initiator  UID                VE Host  Online  Revision  Number of SLIC Zones
-----
I00001    2900006022004183  v1b     Yes    08.17     3
I00002    2900006022004185  v1a     Yes    08.17     1

*****
ZONE SUMMARY

Zone Name  HBA WWN                HBA Name  Initiator  Online  Number of VLUNS
-----
padma_1    210100E08B2358F9      phba      I00001    Yes    2
zeol       210100E08B24AA55      alio1     I00001    Yes    0
zeeo2      210000E08B043080      alioo2    I00001    Yes    1
Undefined  210000E08B043654      Undefined I00001    Yes    0
Undefined  210000E08B0358F9      Undefined I00001    Yes    0
Undefined  210100E08B2480C0      Undefined I00001    Yes    0
Undefined  210100E08B247FC0      Undefined I00001    Yes    0
padma_2    210000E08B042E80      Undefined I00002    Yes    3
Undefined  210000E08B04E70F      Undefined I00002    Yes    0
Undefined  210100E08B243654      Undefined I00002    Yes    0
Undefined  210000E08B047FC0      Undefined I00002    Yes    0
Undefined  210000E08B0480C0      Undefined I00002    Yes    0

*****
#

```

Match the HBA WWN for the Undefined zone from the showvemap(1M) command output with the channel/WWN pair from the output of the script on the host. Use this information to create a VE zone for the HBA for LUN masking operations.

Run the showvemap(1M) command for each virtualization engine pair. If no HBAs are included in the ZONE SUMMARY, run the savevemap(1M) command.

```
# /opt/SUNWsecfg/bin/savevemap -n [v1,v2]
```

The virtualization engine SLIC zones can now be created for LUN masking.

3. For the device channel, the WWN can be determined from the output in Step 1.

The virtualization engine should see the Port WWN of the HBA.

4. Use this channel/WWN combination to create HBA aliases and SLIC zones on the Sun StorEdge 6900 series.

Run the `showvemap` command on the Storage Service Processor to obtain information. For example:

```
# /opt/SUNWsecfg/bin/showvemap -n [v1,v2] -f
```

5. Run the `runsecfg(1M)` command to create HBA aliases and SLIC zones. For example:

```
# /opt/SUNWsecfg/bin/runsecfg
```

6. Select the Virtualization Engine Configuration Utility option and then the Manage Virtualization Engine Zones option to set up a SLIC zone for each HBA.
7. Create the associated VLUNs.

11.3 Creating VLUNs on the Sun StorEdge 6900 Series Storage System for Microsoft Windows 2000

Note – You could create VLUNs through the virtualization Engine Configuration Utility option by issuing the `/opt/SUNWsecfg/bin/runsecfg` command on the Storage Service Processor. See Chapter 5 for information about logging in to the Storage Service Processor or you could follow this command line procedure.

1. Get the virtualization engine pair name, using the `listvemap(1M)` command. For example:

```
# /opt/SUNWsecfg/bin/listvemap -r
v1
#
```

If no virtualization engine names are returned, either the virtualization engine is not functioning or a configuration process is already running.

2. Get the name of the Sun StorEdge T3+ array disk pool, using the `listvemap(1M)` command. For example:

```
# /opt/SUNWsecfg/bin/listvemap -d -n v1
t3b00 t3b01
#
```

In this example, the disk pool name would be `t3b00`.

3. Get the primary zone name, using the `listvemap` command. For example:

```
# /opt/SUNWsecfg/bin/listvemap -z -n v1 -c I00001
labsys_cl
#
```

4. Create the Microsoft Windows 2000 VLUNs, using the `createvlun(1M)` command and only specify a single zone.

The following example entry creates five VLUNs that are 10 Gbytes each for use with Microsoft Windows 2000. The descriptive tag suffix is `w2vlun`.

```
# /opt/SUNWsecfg/bin/createvlun -n v1 -d t3b00 -l 10 -c 5 -v w2vlun -V -z labsys_cl
VLUN T16384 : Created successfully in diskpool t3b00 with name 1w2vlun
VLUN T16385 : Created successfully in diskpool t3b00 with name 2w2vlun
VLUN T16386 : Created successfully in diskpool t3b00 with name 3w2vlun
VLUN T16387 : Created successfully in diskpool t3b00 with name 4w2vlun
VLUN T16388 : Created successfully in diskpool t3b00 with name 5w2vlun
VLUN T16384 T16385 T16386 T16387 T16388 added successfully to zone z
labsys_cl
#
```



Caution – If you are changing other VLUN information using the `runsecfg` menu interface or the Storage Automated Diagnostic Environment GUI interface, these VLUNs will still show up as “available.” To add to a second zone (since two paths to allow for failover are recommended), you must keep track of these Microsoft Windows 2000 VLUNs that have already been added into a single zone (that is, `showvemap -n v1 -f`); adding them into a second zone could cause data corruption problems.

11.4 Setting Up Newly Created VLUNs

1. **Configure and partition disks using the Disk Administrator for Microsoft Windows 2000.**

Refer to the Microsoft Windows 2000 documentation for details.

Connecting to Servers Running the Red Hat Linux 7.2 Operating Environment

Note – See www.sunsolve.sun.com and *Sun StorEdge 3900 and 6900 Series 1.1 Release Notes* for the software requirements for the host. See *High Availability for Sun StorEdge Products Version 1.0 in the Red Hat Linux Operating System* for a description of multipathing in the Red Hat Linux operating system.

This chapter contains the instructions for connecting servers running Red Hat Linux 7.2, Kernel 2.4.7-10 to the Sun StorEdge 3900 and 6900 series storage systems.

See Chapter 8 for a description of how to connect the server and the Sun StorEdge 3900 and 6900 series storage systems.

This chapter contains the following:

- Section 12.1, “Connecting a Sun StorEdge 3900 Series Storage System to a Red Hat Linux Server” on page 12-2
- Section 12.2, “Connecting a Sun StorEdge 6900 Series Storage System to a Red Hat Linux Server” on page 12-3
- Section 12.3, “Creating VLUNs on the Sun StorEdge 6900 Series Storage System for a Red Hat Linux Server” on page 12-5
- Section 12.4, “Setting Up Newly Created VLUNs” on page 12-7

The following tools are required to perform the tasks in this chapter:

- Laptop or server terminal

12.1 Connecting a Sun StorEdge 3900 Series Storage System to a Red Hat Linux Server

The Sun StorEdge 3900 series supports Red Hat Linux 7.2, Kernel 2.4.7-10 with multiLUN supported in either single-path or dual-path configurations. Dual-path configurations use the Red Hat Linux build in the RAID tool.

The important rules for setting up Red Hat Linux servers for a dedicated Hard Zone with the Sun StorEdge 3900 series storage system are:

- Each Red Hat Linux server must be set to a host F port. The associated Sun StorEdge T3+ array partner groups must be in a dedicated Hard Zone that is in SL mode set to a TL port.
- A maximum of one Red Hat Linux server with one initiator is allowed.

1. Set up the Sun multipath failover driver for Red Hat Linux.

If you are going to use a dual path instead of a single path, you must complete this step. See *High Availability for Sun StorEdge Products Version 1.0 in the Red Hat Linux Operating Environment* for detailed instructions about setting up the device driver on the server.

2. Change the Sun StorEdge T3+ array to rw mode.

For each Sun StorEdge T3+ array partner group under dual-path driver control, you must run the `modifyt3params(1M)` command to set the `mp_support` mode to `none`. (By default the Sun StorEdge T3+ arrays in the Sun StorEdge 3900 series storage system are delivered in `mpxio` mode.)

```
# /opt/SUNWsecfg/bin/modifyt3params -n t3name1 t3name2 .. -m none
```

3. Connect the Red Hat Linux server to the available ports.

4. Reboot the Red Hat Linux server.

The reboot must be done to make the recently configured LUNs visible to the server.

12.2 Connecting a Sun StorEdge 6900 Series Storage System to a Red Hat Linux Server

The Sun StorEdge 6900 series storage system supports Red Hat Linux 7.2, Kernel 2.4.7-10 in single-path or dual-path configurations. The Sun StorEdge 6900 series storage system requires a Fabric connection to the Sun StorEdge Network FC switches.

1. Ensure your host bus adapters (HBAs) are operating in F-port mode and obtain the World Wide Name (WWN) for each HBA.

- a. Type the following commands and look for the WWN opposite the node.

```
cat /proc/scsi/qla2x00/0
cat /proc/scsi/qla2x00/1
```

- b. On the QLogic HBA, you can enter the card's BIOS when the Red Hat Linux system is booting. From there, the WWN information can be obtained.

You can also obtain the HBA WWN by running the following command on the Storage Service Processor to determine the HBA WWNs that are directly attached to the internal Sun StorEdge 6900 series FC switch. For example:

```
# /opt/SUNWsecfg/bin/showswitch -s sw1a
...
*****
Name Server
*****

Port   Address   Type   PortWWN           Node WWN           FC-4 Types
-----
01     104000   N      2b0000602200418a  2a0000602200418a  SCSI_FCP
02     104100   N      210000e08b042e80  200000e08b042e80
03     104200   N      210000e08b04465c  200000e08b04465c
04     104300   N      210100e08b24aa55  200100e08b24aa55
...
#
```

The above output shows the virtualization engine WWN and the HBA WWNs.

2. Run the showvemap(1M) command on the Storage Service Processor to see the virtualization engine summary. For example:

```

sp0# /opt/SUNWsecfg/bin/showvemap -n v1 -f
*****
VIRTUALIZATION ENGINE SUMMARY

Initiator  UID                      VE Host  Online  Revision  Number of SLIC Zones
-----
I00001    2900006022004183  v1b     Yes    08.17     3
I00002    2900006022004185  v1a     Yes    08.17     1

*****
ZONE SUMMARY

Zone Name  HBA WWN                  HBA Name  Initiator  Online  Number of VLUNS
-----
padma_1    210100E08B2358F9  phba     I00001    Yes    2
zeol       210100E08B24AA55  alio1    I00001    Yes    0
zeeo2      210000E08B043080  alioo2    I00001    Yes    1
Undefined  210000E08B043654  Undefined I00001    Yes    0
Undefined  210000E08B0358F9  Undefined I00001    Yes    0
Undefined  210100E08B2480C0  Undefined I00001    Yes    0
Undefined  210100E08B247FC0  Undefined I00001    Yes    0
padma_2    210000E08B042E80  Undefined I00002    Yes    3
Undefined  210000E08B04E70F  Undefined I00002    Yes    0
Undefined  210100E08B243654  Undefined I00002    Yes    0
Undefined  210000E08B047FC0  Undefined I00002    Yes    0
Undefined  210000E08B0480C0  Undefined I00002    Yes    0

*****
#

```

Match the HBA WWN for the Undefined zone from the showvemap output with the channel/WWN pair from the output of the script on the host. Use this information to create a virtualization engine zone for the HBA for LUN masking operations.

Run the showvemap command for each virtualization engine pair. If no HBAs show up under the ZONE SUMMARY, run the savevemap(1M) command.

```
# /opt/SUNWsecfg/bin/savevemap -n [v1,v2]
```

The virtualization engine SLIC zones can now be created for LUN masking.

3. For the device channel, the WWN can be determined from the output in Step 1.

The virtualization engine should see the Port WWN of the HBA.

4. Use this channel/WWN combination to create HBA aliases and SLIC zones on the Sun StorEdge 6900 series.

Run the `showvemap(1M)` command on the Storage Service Processor to obtain information. For example:

```
# /opt/SUNWsecfg/bin/showvemap -n [v1,v2] -f
```

5. Run the `runsecfg(1M)` command to create HBA aliases and SLIC zones. For example:

```
# /opt/SUNWsecfg/bin/runsecfg
```

6. Select the Virtualization Engine Configuration Utility option and then the Manage Virtualization Engine Zones option to set up a SLIC zone for each HBA.

Note – This is only a single zone, not a dual path with two zones.

12.3 Creating VLUNs on the Sun StorEdge 6900 Series Storage System for a Red Hat Linux Server

Note – Because a Red Hat Linux server has no failover functionality, you must create VLUNs with only a single-path—that is, a single virtualization engine zone.

Note – You could create VLUNs through the virtualization Engine Configuration Utility option by issuing the `/opt/SUNWsecfg/bin/runsecfg` command on the Storage Service Processor. See Chapter 5 for information about logging into the Storage Service Processor or you could follow this command line procedure.

1. Get the virtualization engine pair name, using the `listvemap(1M)` command. For example:

```
# /opt/SUNWsecfg/bin/listvemap -r
v1
#
```

If no virtualization engine names are returned, either the virtualization engine is not functioning or a configuration process is already running.

2. Get the name of the Sun StorEdge T3+ array disk pool, using the `listvemap(1M)` command. For example:

```
# /opt/SUNWsecfg/bin/listvemap -d -n v1
t3b00 t3b01
#
```

In this example, the disk pool name would be `t3b00`.

3. Get the primary zone name, using the `listvemap` command. For example:

```
# /opt/SUNWsecfg/bin/listvemap -z -n v1 -c I00001
labsys_c1
#
```

4. Create the Red Hat Linux VLUNs, using the `createvlun(1M)` command and only specify a single zone.

The following example entry creates five VLUNs that are 10 Gbytes each for use with Red Hat Linux. The descriptive tag suffix is `lnvlun`.

```
# /opt/SUNWsecfg/bin/createvlun -n v1 -d t3b00 -l 10 -c 5 -v lnvlun -V -z labsys_c1
VLUN T16384 : Created successfully in diskpool t3b00 with name 1lnvlun
VLUN T16385 : Created successfully in diskpool t3b00 with name 2lnvlun
VLUN T16386 : Created successfully in diskpool t3b00 with name 3lnvlun
VLUN T16387 : Created successfully in diskpool t3b00 with name 4lnvlun
VLUN T16388 : Created successfully in diskpool t3b00 with name 5lnvlun
VLUN T16384 T16385 T16386 T16387 T16388 added successfully to zone z
labsys_c1
#
```

12.4 Setting Up Newly Created VLUNs

1. **Configure and partition disks using the Disk Administrator for Red Hat Linux.**
See *High Availability for Sun StorEdge Products Version 1.0 in the Red Hat Linux Operating Environment*.

Product Specifications

This appendix contains the following sections:

- Section A.1 “Physical Characteristics” on page A-1
- Section A.2 “Physical Specifications” on page A-2
- Section A.3 “Clearance and Service Access” on page A-3
- Section A.4 “Power Sequencer Electrical Specifications” on page A-4
- Section A.5 “Environmental Requirements” on page A-4

A.1 Physical Characteristics

The physical characteristics of the Sun StorEdge 3900 and 6900 series storage systems are as follows:

- Internal dimensions conform to EIA RS-310C standard (RETMA) for 19-inch (482 millimeter.) cabinets. Universal mounting holes are used with 10-32UNF tapped holes in all locations. The nominal rack opening is 17.875 inches (454 millimeter.).
- A vertical panel opening of 36 rack units (RUs) minimum is provided to accommodate various rack-mountable FRUs. One RU is equal to 1.75 inches (44.45 millimeter.).
- Overall storage system height with cosmetic panels is 75 inches (191 cm) maximum.



Caution – Make no mechanical or electrical modifications to this storage system. Sun Microsystems is not responsible for the regulatory compliance if the storage system is modified.

A.2 Physical Specifications

TABLE A-1 Storage System Physical Specifications

Subsystem	Height	Width	Depth	Weight
Sun StorEdge 3900SL storage system single cabinet	75 in. 109.5 cm	23.9 in. 60.7 cm	37 in. 94 cm	1465 lb 665 kg
Sun StorEdge 3900SL storage system with expansion cabinet	75 in. 109.5 cm	47.8 in. 122 cm	37 in. 94 cm	2855 lb 1295 kg
Sun StorEdge 3910 storage system	75 in. 109.5 cm	23.9 in. 60.7 cm	37 in. 94 cm	1465 lb 665 kg
Sun StorEdge 3960 storage system	75 in. 109.5 cm	47.8 in. 122 cm	37 in. 94 cm	2855 lb 1295 kg
Sun StorEdge 6910 storage system	75 in. 109.5 cm	23.9 in. 60.7 cm	37 in. 94 cm	1210 lb 549 kg
Sun StorEdge 6910SL storage system	75 in. 109.5 cm	23.9 in. 60.7 cm	37 in. 94 cm	1210 lb 549 kg
Sun StorEdge 6960 storage system	75 in. 109.5 cm	47.8 in. 121.4 cm	37 in. 94 cm	2895 lb 1314 kg
Sun StorEdge 6960SL storage system	75 in. 109.5 cm	47.8 in. 121.4 cm	37 in. 94 cm	2895 lb 1314 kg
Note: The values given in this table are for the maximum hardware configuration available including the Sun StorEdge expansion cabinet in both the Sun StorEdge 3900SL, 3960, 6960, and 6960SL storage systems.				

The power cords are 15 feet (4.6 meters) long.

A.3 Clearance and Service Access

TABLE A-2 Clearance and Service Access for Sun StorEdge 3910 and 6910 Subsystems

Location	For Service Access
Front	48 in. 122 cm
Rear	36 in. 92 cm
Left	36 in. 92 cm
Right	36 in. 92 cm.

TABLE A-3 Clearance and Service Access for Sun StorEdge 3960 and 6960 Subsystems

Location	For Service Access
Front	96 in. 244 cm
Rear	60 in. 153 cm
Left	60 in. 153 cm
Right	60 in. 153 cm

A.4 Power Sequencer Electrical Specifications

TABLE A-4 Power Sequencer Electrical Specifications

Parameter	Value(s)
AC voltage rating	200 to 240 VAC
AC voltage range	180 to 264 VAC
Frequency range	47 to 63 Hz
Current at 240 VAC	32A
Power consumption, maximum	
Sun StorEdge 3910 storage system	4.2kW
Sun StorEdge 3960 storage system	8.4kW
Sun StorEdge 6910 storage system	4.2kW
Sun StorEdge 6960 storage system	8.4kW

A.5 Environmental Requirements

The operating environment limits in TABLE A-5 are what the systems are tested to in order to meet all functional requirements. The optimum operating condition in TABLE A-6 is the recommended operating environment.

TABLE A-5 Operating Environment Requirements

Parameter	Operating	Nonoperating
Temperature	41°F to 95°F (5°C to 35°C)	-41°F to 140°F (-20°C to 60°C)

TABLE A-5 Operating Environment Requirements (*Continued*)

Parameter	Operating	Nonoperating
Relative Humidity (RH)	20% to 80% RH, noncondensing 80.6°F (27°C) maximum wet bulb	5% to 93% RH, noncondensing
Altitude	-1000 to 10,000 feet (-305 to 3,048 meters)	-1000 to 40,000 feet (-305 to 12,192 meters)
Environment	<p>Avoid temperature extremes and keep the work area clean. Maintain the operating conditions described. The storage system should be in a computer room environment. A computer room environment should provide secure access to computers and stored information, and provides control over environmental factors such as temperature, humidity, and airborne dust. A computer room installation can also help protect equipment from fire, flood, or other danger originating in the building.</p>	

TABLE A-6 Optimum Ambient Environmental Operating Conditions

Environmental Factor	Ambient Temperature Range	Ambient Relative Humidity
Operating	70°F to 73.5°F (21°C to 23°C)	45% to 50%

Index

A

adding a cabinet in the field, 3-2, 3-6

C

cabinet

adding to a configuration, 3-6

clearance access, Sun StorEdge 3900 and 6900 series, A-3

Composite map, displaying for a Sun StorEdge T3+ array, 7-17

configuring

Sun StorEdge 3900 and 6900 series setup, 7-1

Sun StorEdge 3900 storage system, 7-2

Sun StorEdge 3900SL storage system cabinets into a solution, 7-23

Sun StorEdge 3960 storage system cabinets into a solution, 7-23

Sun StorEdge 6900 series, 7-26

Sun StorEdge 6960 storage system cabinets into a solution, 7-37

Sun StorEdge 6960SL storage system cabinets into a solution, 7-37

configuring the `ssd.conf` file, 9-5

connecting

to Sun servers, 9-1

connecting fibre channel cables

Sun StorEdge 6960 storage system expansion cabinet, 3-6

connecting second cabinet

Ethernet Cable, Sun StorEdge 3900SL and 3960 storage system, 3-4

Sun StorEdge 6960 storage system, 3-6

connecting to

Microsoft Windows 2000 servers, 11-1

Microsoft Windows NT servers, 10-1

Red Hat Linux servers, 12-1

connecting to Sun servers

cascaded switches on Sun StorEdge 6900 series, setting up, 9-23

matching the host WWN to the device channel, 9-8

newly created VLUNs, setting up, 9-18

Solaris server, setting up, 9-2

`ssd.conf` file, configuring, 9-5

Sun StorEdge Traffic Manager, configuring, 9-7

VERITAS volume manager support, setting up, 9-19

VLUNs to devices mapping, 9-21

creating multiple zones, Sun StorEdge 6900 series, 7-29

D

description

Sun StorEdge 3900SL storage system, 1-2

Sun StorEdge 3910 storage system, 1-1

Sun StorEdge 3960 storage system, 1-2

Sun StorEdge 6910 storage system, 1-2

Sun StorEdge 6910SL storage system, 1-2

Sun StorEdge 6960 storage system, 1-3

Sun StorEdge 6960SL storage system, 1-3

Disk Administrator for Red Hat Linux to configure and partition disks, 12-7

E

- Ethernet cable
 - connecting in a Sun StorEdge 3960 storage system, 3-4
 - connecting Sun StorEdge 3900SL and 3960 storage system second cabinet, 3-4
 - connecting Sun StorEdge 6960 storage system and second cabinet, 3-8
- expansion cabinet
 - connecting to a Sun StorEdge 6960 storage system, 3-6
- expansion cabinets
 - configuring Sun StorEdge 3900 series storage system, 7-23
 - configuring Sun StorEdge 6900 series into a solution, 7-37

F

- Fibre channel cables
 - connecting Sun StorEdge 3960 storage system, 3-2
 - connecting Sun StorEdge 6960 storage system second cabinet, 3-6
- field installation instructions
 - setting the IP address, Storage Service Processor, 5-7

G

- ground strap, connecting, 4-6
- group
 - removing from a Sun StorEdge T3+ array, 7-15

H

- host
 - connecting the Sun StorEdge 3900SL storage system, 8-7
 - connecting the Sun StorEdge 3910 storage system, 8-1
 - connecting the Sun StorEdge 3960 storage system, 8-4
 - connecting the Sun StorEdge 6910 storage system, 8-1
 - connecting the Sun StorEdge 6910SL and 6960SL

storage systems, 8-7

- connecting the Sun StorEdge 6960 storage system, 8-4
- host WWN to the device channel, matching, 9-8

I

- isolating common installation problems, 4-11

K

- key switch, power up position, 4-8

L

- LAN
 - attaching a Sun StorEdge 3900 or 6900 series storage system, 8-7
- local/remote switch, power on position, 4-9
- LUN
 - creating SLIC zones for LUN masking, 9-8
 - setting permissions, Sun StorEdge T3+ array, 7-8
 - slicing, Sun StorEdge T3+ array, 7-4
 - Sun StorEdge 3900 series masking set up, 7-3
 - Sun StorEdge 3900 series slicing setting up, 7-3
 - Sun StorEdge T3+ array masking procedure, 7-6

M

- mapping VLUNs to devices, 9-21
- Microsoft Windows 2000 servers
 - connecting a Sun StorEdge 3900 series, 11-2
 - connecting a Sun StorEdge 6900 series, 11-2
 - connecting to, 11-1
 - setting up newly created VLUNs, 11-7
- Microsoft Windows NT servers
 - connecting a Sun StorEdge 3900 series, 10-2
 - connecting a Sun StorEdge 6900 series, 10-3
 - connecting to, 10-1
 - setting up newly created VLUNs, 10-7
- multiple zones, Sun StorEdge 6900 series, 7-28

N

- Network Information Service (NIS) naming service,

- customer use, 8-7
- Network Terminal Concentrator
 - power on, remote response unit, 6-2
- NT servers
 - connecting to, 10-1, 12-1

O

- operating environment requirements, A-4
- optimum ambient environmental operating conditions, A-4, A-5

P

- power cord, connecting procedure, 4-3
- Power Sequencer Electrical Specifications, A-4
- power status indicators, stage sequences, 4-10
- powering on storage system procedure, 4-7

R

- Red Hat Linux servers
 - connecting a Sun StorEdge 3900 series, 12-2
 - connecting a Sun StorEdge 6900 series, 12-3
 - connecting to, 12-1
 - setting up newly created VLUNs, 12-7
 - Using Disk Administrator to configure and partition disks, 12-7
- remote response unit
 - powering on, 6-1

S

- second cabinet
 - connecting to a storage system, 3-1
- service access, Sun StorEdge 3900 and 6900 series, A-3
- setting up cascaded switches on Sun StorEdge 6900 series, 9-23
- SLIC zones for LUN masking, creating, 9-8
- software setup instructions
 - attaching a Sun StorEdge 3900 or 6900 series to a LAN, 8-7
 - making a connection to the Storage Service Processor from a remote system, 5-3
 - making a connection to the Storage Service

- Processor from onsite system, 5-2
- setting the date and time zone, Storage Service Processor, 5-8
- setting the host name, Storage Service Processor, 5-4
- setting the IP address, 5-8
- Storage Service Processor, 5-1
- verifying the configuration, Storage Service Processor, 5-8
- Solaris server, setting up, 9-2
- Solaris Volume Manager, volume management software installation, 9-4
- Solution Center, Sun StorEdge Remote Response information for startup, 6-7
- Storage Service Processor
 - logging in from a remote system, 5-3
 - logging in from onsite, 5-2
 - software setup instructions, 5-1
- storage system environmental requirements, A-4
- storage system, powering off, 4-12
- storage system, powering on procedure, 4-7
- Sun servers, 9-1
 - connecting to, 9-1
- Sun Solaris server
 - patches to install for Solaris 8, 9-2
 - patches to install for Solaris 9, 9-2
- Sun StorEdge 3900 series
 - connecting to Microsoft Windows 2000 servers, 11-2
 - connecting to Microsoft Windows NT servers, 10-2
 - connecting to Red Hat Linux servers, 12-2
 - connecting to Solaris servers, 9-1
 - physical characteristics, A-1
 - physical specifications, A-2
- Sun StorEdge 3900 series, powering off procedure, 4-12
- Sun StorEdge 3900SL storage system
 - connecting to the host, 8-7
 - second cabinet note, 3-2
- Sun StorEdge 3900SL storage system, description, 1-2
- Sun StorEdge 3910 storage system
 - connecting to the host, 8-1
- Sun storEdge 3910 storage system description, 1-1
- Sun StorEdge 3960 storage system
 - connecting the second cabinet, 3-2
 - connecting to the host, 8-4

- description, 1-2
- Sun StorEdge 6900 series
 - configuring, 7-26
 - connecting to Microsoft Windows 2000 servers, 11-2
 - connecting to Microsoft Windows NT server, 10-3
 - connecting to Red Hat Linux servers, 12-3
 - connecting to Solaris servers, 9-1
 - creating multiple VLUNS with zones, 7-32
 - creating multiple VLUNS without zones, 7-32
 - creating multiple zones, 7-29
 - physical characteristics, A-1, A-2
 - setting up multiple zones, 7-28
 - Solaris server connection requirements, 9-5
- Sun StorEdge 6910 storage system
 - connecting to the host, 8-1
 - description, 1-2
- Sun StorEdge 6910SL and 6960SL storage system,
 - connecting to the host, 8-7
- Sun StorEdge 6910SL storage system
 - description, 1-2
- Sun StorEdge 6960 storage system
 - connecting to the host, 8-4
 - description, 1-3
- Sun StorEdge 6960SL storage system
 - description, 1-3
 - second cabinet note, 3-6
- Sun StorEdge Remote Responce unit
 - power on the modem, 6-2
- Sun StorEdge Remote Response unit
 - information needed for setup, 6-1
 - Solution Center information, 6-7
- Sun StorEdge T3+ array
 - adding a WWN to a Sun StorEdge T3+ array, 7-14
 - deleting a WWN, 7-11
 - displaying the composite map, 7-17
 - LUN masking procedure, 7-6
 - LUN slices, 7-4
 - removing a group, 7-15
 - setting LUN permissions, 7-8
 - volume slicing procedure, 7-3
- Sun StorEdge Traffic Manager
 - connecting to Sun servers, 9-7

V

- VERITAS 3.2, patches to install, 9-4
- VERITAS 3.2, volume management software
 - installation, 9-4
- VERITAS volume manager
 - setting up support, 9-19
- VERITAS volume manager support, setting up, 9-19
- VLUNs on Sun StorEdge 6900 series
 - using Microsoft Windows 2000 to create, 11-5
 - using Microsoft Windows NT to create, 10-5
 - using Red Hat Linux operating system to create, 12-6
- VLUNs, setting up newly created, 9-18
- volume slicing, Sun StorEdge t3+ array
 - procedure, 7-3

W

- WWN
 - adding to a Sun StorEdge T3+ array, 7-14
 - deleting from a Sun StorEdge T3+ array, 7-11
 - matching the host to the device channel, 9-8