



# Solaris™ 8 4/01 Sun™ Hardware Platform Guide

---

Sun Microsystems, Inc.  
901 San Antonio Road  
Palo Alto, CA 94303-4900  
U.S.A. 650-960-1300

Part No. 806-7482-10  
April 2001, Revision A

Send comments about this document to: [docfeedback@sun.com](mailto:docfeedback@sun.com)

Copyright 2001 Sun Microsystems, Inc., 901 San Antonio Road, Palo Alto, California 94303-4900 U.S.A. All rights reserved.

This product or document is protected by copyright and distributed under licenses restricting its use, copying, distribution, and decompilation. No part of this product or document may be reproduced in any form by any means without prior written authorization of Sun and its licensors, if any. Third-party software, including font technology, is copyrighted and licensed from Sun suppliers.

Parts of the product may be derived from Berkeley BSD systems, licensed from the University of California. UNIX is a registered trademark in the U.S. and other countries, exclusively licensed through X/Open Company, Ltd. For Netscape Communicator™, the following notice applies: Copyright 1995 Netscape Communications Corporation. All rights reserved.

Sun, Sun Microsystems, the Sun logo, AnswerBook, AnswerBook2, Solaris, Sun Enterprise, Sun StorEdge, SPARCstorage, SPARCserver, ShowMe TV, SunFDDI, SunForum, SunVTS, and Ultra are trademarks, registered trademarks, or service marks of Sun Microsystems, Inc. in the U.S. and other countries. All SPARC trademarks are used under license and are trademarks or registered trademarks of SPARC International, Inc. in the U.S. and other countries. Products bearing SPARC trademarks are based upon an architecture developed by Sun Microsystems, Inc.

The OPEN LOOK and Sun™ Graphical User Interface was developed by Sun Microsystems, Inc. for its users and licensees. Sun acknowledges the pioneering efforts of Xerox in researching and developing the concept of visual or graphical user interfaces for the computer industry. Sun holds a non-exclusive license from Xerox to the Xerox Graphical User Interface, which license also covers Sun's licensees who implement OPEN LOOK GUIs and otherwise comply with Sun's written license agreements.

RESTRICTED RIGHTS: Use, duplication, or disclosure by the U.S. Government is subject to restrictions of FAR 52.227-14(g)(2)(6/87) and FAR 52.227-19(6/87), or DFAR 252.227-7015(b)(6/95) and DFAR 227.7202-3(a).

DOCUMENTATION IS PROVIDED "AS IS" AND ALL EXPRESS OR IMPLIED CONDITIONS, REPRESENTATIONS AND WARRANTIES, INCLUDING ANY IMPLIED WARRANTY OF MERCHANTABILITY, FITNESS FOR A PARTICULAR PURPOSE OR NON-INFRINGEMENT, ARE DISCLAIMED, EXCEPT TO THE EXTENT THAT SUCH DISCLAIMERS ARE HELD TO BE LEGALLY INVALID.

---

Copyright 2001 Sun Microsystems, Inc., 901 San Antonio Road, Palo Alto, California 94303 Etats-Unis. Tous droits réservés.

Ce produit ou document est protégé par un copyright et distribué avec des licences qui en restreignent l'utilisation, la copie, la distribution, et la décompilation. Aucune partie de ce produit ou document ne peut être reproduite sous aucune forme, par quelque moyen que ce soit, sans l'autorisation préalable et écrite de Sun et de ses bailleurs de licence, s'il y en a. Le logiciel détenu par des tiers, et qui comprend la technologie relative aux polices de caractères, est protégé par un copyright et licencié par des fournisseurs de Sun.

Des parties de ce produit pourront être dérivées des systèmes Berkeley BSD licenciés par l'Université de Californie. UNIX est une marque déposée aux Etats-Unis et dans d'autres pays et licenciée exclusivement par X/Open Company, Ltd. La notice suivante est applicable à Netscape Communicator™ : Copyright 1995 Netscape Communications Corporation. All rights reserved.

Sun, Sun Microsystems, the Sun logo, AnswerBook, AnswerBook2, Sun Enterprise, Sun StorEdge, SPARCstorage, SPARCserver, ShowMe TV, SunFDDI, SunForum, SunVTS, Ultra, et Solaris sont des marques de fabrique ou des marques déposées, ou marques de service, de Sun Microsystems, Inc. aux Etats-Unis et dans d'autres pays. Toutes les marques SPARC sont utilisées sous licence et sont des marques de fabrique ou des marques déposées de SPARC International, Inc. aux Etats-Unis et dans d'autres pays. Les produits portant les marques SPARC sont basés sur une architecture développée par Sun Microsystems, Inc.

L'interface d'utilisation graphique OPEN LOOK et Sun™ a été développée par Sun Microsystems, Inc. pour ses utilisateurs et licenciés. Sun reconnaît les efforts de pionniers de Xerox pour la recherche et le développement du concept des interfaces d'utilisation visuelle ou graphique pour l'industrie de l'informatique. Sun détient une licence non exclusive de Xerox sur l'interface d'utilisation graphique Xerox, cette licence couvrant également les licenciés de Sun qui mettent en place l'interface d'utilisation graphique OPEN LOOK et qui en outre se conforment aux licences écrites de Sun.

CETTE PUBLICATION EST FOURNIE "EN L'ETAT" ET AUCUNE GARANTIE, EXPRESSE OU IMPLICITE, N'EST ACCORDEE, Y COMPRIS DES GARANTIES CONCERNANT LA VALEUR MARCHANDE, L'APTITUDE DE LA PUBLICATION A REPENDRE A UNE UTILISATION PARTICULIERE, OU LE FAIT QU'ELLE NE SOIT PAS CONTREFAISANTE DE PRODUIT DE TIERS. CE DENI DE GARANTIE NE S'APPLIQUERAIT PAS, DANS LA MESURE OU IL SERAIT TENU JURIDIQUEMENT NUL ET NON AVENU.



# Contents

---

**Preface** xi

**1. Installing Software From the Solaris CD** 1

Automatic Installation of Solaris Software 1

Manual Installation of Solaris Software 1

Platform Names and Groups 2

Interactive Installation of Solaris Software 4

Manual Installation of Packages 8

Custom JumpStart Profiles 10

32-bit Kernel—Default on 200MHz or Lower UltraSPARC Systems 12

**2. Supported Sun Hardware** 15

Supported Platforms 15

**3. Installing Software from the Software Supplement for the Solaris 8 Operating Environment 4/01 CD** 17

Installing Supplement CD Software 18

Before Installing Supplement CD Software 19

Installing Supplement CD Software Using Solaris Web Start 2.0 19

Installing Supplement CD Software on a Standalone System Using pkgadd 20

Validation Test Suite Software (SunVTS Software)	23
SunVTS Packages	25
Installing SunVTS	25
Using SunVTS Software	25
OpenGL Software	25
Supported Platforms	26
Removing Old Packages	26
OpenGL Packages	27
Installing OpenGL	28
After Installing the Packages	28
Unexpected Slow Local Rendering	29
PC Launcher	30
Audience	30
What is PC Launcher?	30
PC Launcher Installation Requirements	30
System Requirements	31
PC Launcher Installation	31
Configuring PC Launcher	32
Using PC Launcher	34
Working With Windows Files	35
Other Features	36
Getting Help for PC Launcher	36
PC File Viewer	37
PC File Viewer	37
File Formats Supported	37
PC File Viewer Limitations	38
Installing PC File Viewer	38

Adding PC File Viewer to the CDE Front Panel	39
ShowMe TV 1.3 Software	39
ShowMe TV Packages	40
Removing Old Packages	40
Installing ShowMe TV	40
Translated Documentation	41
Sun Remote System Control for Sun Servers	42
SunForum	42
Installing SunForum	43
Online Help	43
Network Adapter Drivers Included on the Supplement CD	43
Installing the Drivers	44
Platform Notes for Network Adapter Drivers	44
Java 3D 1.2 API	44
Installation Dependencies	44
Installing Java 3D 1.2 API	44
Sun Enterprise 10000 SSP Software	45
Sun Enterprise 10000 Capacity on Demand 1.0 Software	45
Netra ct Platform Software	45
<b>4. Documents on the Computer Systems Supplement CD</b>	<b>47</b>
AnswerBook2 Sets	47
Installing Solaris 8 4/01 AnswerBook Sets	47
Solaris 8 4/01 AnswerBook Packages	48
Solaris 8 4/01 on Sun Hardware AnswerBook Set	48
Sun Enterprise 10000 SSP AnswerBook Set	50
Alternate Pathing AnswerBook Set	51
Capacity On Demand AnswerBook Set	51

Sun Computer Systems Manual Page Packages	51
Installing Sun Computer Systems Manual Pages	52
Using Sun Computer Systems Manual Pages	52
Other Documents on the Computer Systems Supplement CD	52
<b>5. Updating the Flash PROM on the Ultra 1, Ultra 2, Ultra 450, and Sun Enterprise 450 Systems</b>	<b>55</b>
Related Material	55
Determining If the Flash PROM Needs Updating	56
▼ To Determine If Your System Requires a Flash PROM Update	56
Updating the Flash PROM	57
Capturing Configuration Variable Settings	58
Making the Flash PROM Write-Enabled	59
Before Updating the Flash PROM	63
Recovering From a Power Failure During the Flash PROM Update	67
Sun Ultra 1 and Ultra 2 Systems, Sun Enterprise 450 System, Sun Ultra 450 Workstation	68
Restoring NVRAM Configuration Variables	70
Error Messages	72
Retained Page/mmap Failure	72
Location of Flash PROM Jumpers in Sun Enterprise 450 System and the Ultra 450 Workstation	73
Flash PROM Update Multimedia Collection	75
▼ Running the Video Clips from the CD	75
▼ Running an AnswerBook2 Server from the CD	76
Notes on Running AnswerBook2 from a CD	77
<b>6. Updating the Flash PROM on the Sun Enterprise 3x00, 4x00, 5x00, and 6x00 Systems</b>	<b>79</b>
Determining If the Flash PROM Needs Updating	79

▼	To Determine If Your System Requires a Flash PROM Update	80
	Updating the Flash PROM	81
	Flash PROM Update Process	81
	Capturing Configuration Variable Settings	82
	Making the Flash PROM Write-Enabled	83
	Before Updating the Flash PROM	84
	Location of Flash PROM Jumpers in Sun Enterprise Server Systems	93
	Installing the P0601 Jumper	94
	Recovering From a Power Failure During the Flash PROM Update	96
	Sun Enterprise 3x00, 4x00, 5x00, and 6x00 Systems	96
<b>7.</b>	<b>Power Management on Sun Hardware</b>	<b>101</b>
	Supported Platforms and System Distinctions	101
	System Architecture Distinctions and Default Settings	103
	SPARCstation 4 Issues	103
<b>8.</b>	<b>Alternate Pathing 2.3.1 on the Sun Enterprise servers</b>	<b>105</b>
	Preparing to Install or Upgrade	105
▼	To Install or Upgrade From the Web	106
▼	To Install or Upgrade From a CD-ROM	106
▼	To Mount a CD-ROM over NFS™	107
	Performing an Initial Installation of AP	109
	ssd Patch	110
▼	To Manually Install AP 2.3.1	113
	Installing the AP 2.3.1 AnswerBook2 Collection	119
	AP 2.3.1 AnswerBook2 Collection	120
▼	To Install the AP 2.3.1 AnswerBook2 Collection	120

Before Performing an Upgrade of AP	122
Backing Up Your Server	123
Uncommitted AP Database Entries	123
Checking Other Software Documentation	123
Simultaneously Upgrading AP and Solaris Software	124
Performing an Upgrade of AP	125
▼ To Upgrade to AP 2.3.1	126
<b>9. OpenBoot Emergency Procedures</b>	<b>131</b>
OpenBoot Emergency Procedures for Systems with Standard (non-USB) Keyboards	131
OpenBoot Emergency Procedures for Systems with USB Keyboards	132
Stop-A	132
Stop-N Equivalent	132
Stop-F Functionality	133
Stop-D Functionality	134
<b>10. Sun Fire 6800/4810/4800/3800 Systems Solaris Operating Environment Commands</b>	<b>135</b>
Installing, Booting, and Halting the Solaris Operating Environment	135
▼ To Install and Boot the Solaris Operating Environment for the First Time	135
▼ To Halt the Solaris Operating Environment	136
Solaris Operating Environment Software	137
IP Multipathing (IPMP) Software	137
Sun Management Center 3.0 Platform Update 1 Software	138
Reliability, Availability and Serviceability (RAS)	138
Nomenclature Serviceability Feature	139
syslog Loghost	139
Displaying System Configuration Information	140



prtconf Command	140
prtdiag Command	140
sysdef Command	140
format Command	141

**A. Localized Packages on the Supplement CD 143**

Japanese Localized Packages	143
German Localized Packages	145
Italian Localized Packages	146
French Localized Packages	147
Spanish Localized Packages	147
Swedish Localized Packages	148
Traditional Chinese Localized Packages	149
Simplified Chinese Localized Packages	150
Korean Localized Packages	151



# Preface

---

The *Solaris 8 4/01 Sun Hardware Platform Guide* contains important information about the Sun™ hardware supported by the Solaris™ 8 4/01 operating environment.

This manual:

- Provides platform-specific installation instructions for the Solaris 8 4/01 software
- Describes software provided on the Sun Computer Systems Supplement CD and explains how to install product software
- Describes flash PROM update procedures necessary for some systems to run in 64-bit mode
- Describes hardware and software requirements affecting Power Management™ software

---

**Note** – For general Solaris 8 4/01 operating environment installation instructions, refer to Chapter 1. For information about how to install software contained on the Sun Computer Systems Supplement CD and information about supported hardware, refer to Chapter 3, “Installing Software from the Sun Computer Systems Supplement CD”.

---

---

## Where to Find Installation Information

The Solaris 8 4/01 software is delivered on three CDs:

- Solaris 8 4/01 SPARC™ Platform Edition CDs (called the Solaris CDs throughout this manual)
- Supplement for Solaris 8 4/01 Operating Environment for Sun Computer Systems CD (called the Supplement CD throughout this manual).

Before installing the Solaris 8 4/01 software, check TABLE P-1 for listings of manuals with information that may apply to your situation and TABLE P-2 for specific installation information.

---

**Note** – All Solaris and SPARC documentation can be found on the Documentation CD. All Sun hardware-specific documentation can be found on the Supplement CD. Some co-packaged products contain documentation on their respective CDs.

---

**TABLE P-1** Related Documentation

Title	Description
<i>Solaris 8 SPARC Installation Instructions</i>	Primary installation manual for this release of the Solaris operating environment from the Documentation CD
<i>Solaris 8 (SPARC Platform Edition) Installation Library</i>	Supplements the <i>Solaris Start Here</i> card by providing detailed installation information
<i>Solaris Advanced Installation Guide</i>	Contains additional information about how to install the Solaris operating environment on server systems

**TABLE P-2** Specific Installation Information

If you want to	Go to
Know more about new products and peripherals	Chapter 3 in this manual
Know about late-breaking news	1. <i>Solaris 8 4/01 Release Notes Supplement for Sun Hardware</i> 2. <i>Solaris 8 4/01 Release Notes</i>
Begin the installation process from the Solaris CDs	1. <i>Solaris 8 4/01 Sun Hardware Platform Guide</i> 2. <i>Solaris 8 SPARC Installation Instructions</i>
Install software for your platform/peripheral from the Supplement CD	Chapter 3 in this manual
Update your flash PROM for 64-bit operation	Chapter 5 and Chapter 6 in this manual
Install an AnswerBook™ from the Supplement CD	Chapter 4 in this manual

---

# How This Book Is Organized

This book is organized as follows:

Chapter 1 supports the *Solaris 8 Start Here* card by providing additional installation instructions on how to install or upgrade to the Solaris 8 4/01 software on specific Sun platforms and hardware options.

Chapter 2 lists supported Sun hardware.

Chapter 3 describes how to install the software for Sun platforms and hardware options and describes value-added software provided to users of Sun hardware.

Chapter 4 describes the locations and formats for the documentation on the Supplement CD.

Chapter 5 describes the procedure for updating the flash PROMs for 64-bit operation on Ultra™ 1, Ultra 2, Ultra 450, and Sun Enterprise 450 systems.

Chapter 6 describes the procedure for updating the flash PROMs for 64-bit operation on Sun Enterprise™ 3x00, 4x00, 5x00, and 6x00 systems.

Chapter 7 describes the hardware and software requirements for running the Power Management software on Sun hardware.

Chapter 8 describes installation of Alternate Pathing software.

Chapter 9 describes new OpenBoot™ emergency procedures for some systems.

Chapter 10 describes installation of the Solaris 8 4/01 operating environment on the Sun Fire™ 6800/4810/4800/3800 systems.

---

# Typographic Conventions

TABLE P-3 Typographic Conventions

Typeface or Symbol	Meaning	Example
AaBbCc123	The names of commands, files, and directories; on-screen computer output	Edit your <code>.login</code> file. Use <code>ls -a</code> to list all files. <code>machine_name%</code> You have mail.
<b>AaBbCc123</b>	What you type, contrasted with on-screen computer output	<div style="border: 1px solid black; padding: 5px;"><code>machine_name% su</code> <code>Password:</code></div>
<i>AaBbCc123</i>	Command-line placeholder: replace with a real name or value	To delete a file, type <code>rm filename</code> .
<i>AaBbCc123</i>	Book titles, new words or terms, or words to be emphasized	Read Chapter 6 in <i>User's Guide</i> . These are called <i>class</i> options. You <i>must</i> be root to do this.

---

## Sun Documentation on the Web

The `docs.sun.com`<sup>SM</sup> web site enables you to access Sun technical documentation on the Web. You can browse the `docs.sun.com` archive or search for a specific book title or subject at:

`http://docs.sun.com`

---

## Sun Welcomes Your Comments

We are interested in improving our documentation and welcome your comments and suggestions. You can email your comments to us at:

`docfeedback@sun.com`

Please include the part number of your document in the subject line of your email.

---

# Ordering Sun Documentation

Fatbrain.com, an Internet professional bookstore, stocks select product documentation from Sun Microsystems, Inc.

For a list of documents and how to order them, visit the Sun Documentation Center on Fatbrain.com at:

<http://www.fatbrain.com/documentation/sun>





## Installing Software From the Solaris CD

- 
- “Automatic Installation of Solaris Software” on page 1
  - “Manual Installation of Solaris Software” on page 1
  - “Custom JumpStart Profiles” on page 10
  - “32-bit Kernel—Default on 200MHz or Lower UltraSPARC Systems” on page 12

---

## Automatic Installation of Solaris Software

For the Sun hardware listed in TABLE 1-1, the Solaris 8 release requires no special installation or upgrade instructions. If you plan to perform an automatic installation of the Solaris 8 4/01 operating environment on your Sun hardware, refer to the *Solaris 8 (SPARC Platform Edition) Installation Guide* or the *Solaris Advanced Installation Guide* for all your installation needs.

---

## Manual Installation of Solaris Software

If you are installing the Solaris 8 4/01 operating environment using the manual (or interactive) method, you may need to add some software packages and clusters. This section identifies platform-specific installation needs and lists the required software packages and clusters. The manual installation method is described in the “Planning Your Installation” module of the *Solaris 8 (SPARC Platform Edition) Installation Guide*.

# Platform Names and Groups

You need to know your system architecture (platform group), if you are performing one of the following tasks:

- Setting up a boot server on a subnet
- Adding clients for network installation (standalone, servers, dataless, diskless)

If you are writing a custom JumpStart™ installation rules file, you need to know the platform name.

TABLE 1-1 shows the platform names and platform groups of various Sun hardware systems.

**TABLE 1-1** Platform Names for Sun Systems

System	Platform Name	Platform Group
SPARCclassic™	SUNW,SPARCclassic	sun4m
SPARCstation™ LX	SUNW,SPARCstation-LX	sun4m
SPARCstation LX+	SUNW,SPARCstation-LX+	sun4m
SPARCstation 4	SUNW,SPARCstation-4	sun4m
SPARCstation 5	SUNW,SPARCstation-5	sun4m
SPARCstation 5 Model 170	SUNW,SPARCstation-5	sun4m
SPARCstation 10	SUNW,SPARCstation-10	sun4m
SPARCstation 10SX	SUNW,SPARCstation-10,SX	sun4m
SPARCstation 20	SUNW,SPARCstation-20	sun4m
Ultra 1 Model 140	SUNW,Ultra-1	sun4u
Ultra 1 Model 170	SUNW,Ultra-1	sun4u
Ultra 1 Creator Model 140E	SUNW,Ultra-1	sun4u
Ultra 1 Creator3D Model 140E	SUNW,Ultra-1	sun4u
Ultra 1 Creator Model 170E	SUNW,Ultra-1	sun4u
Ultra 1 Creator 3D Model 170E	SUNW,Ultra-1	sun4u
Ultra 1 Creator Model 200E	SUNW,Ultra-1	sun4u
Ultra 1 Creator3D Model 200E	SUNW,Ultra-1	sun4u
Sun Enterprise 1 Model 140	SUNW,Ultra-1	sun4u
Sun Enterprise 1 Model 170	SUNW,Ultra-1	sun4u
Sun Enterprise 1 Model 170E	SUNW,Ultra-1	sun4u
Ultra 2 Creator Model 1170	SUNW,Ultra-2	sun4u

**TABLE 1-1** Platform Names for Sun Systems *(Continued)*

<b>System</b>	<b>Platform Name</b>	<b>Platform Group</b>
Ultra 2 Creator3D Model 1170	SUNW,Ultra-2	sun4u
Ultra 2 Creator Model 2170	SUNW,Ultra-2	sun4u
Ultra 2 Creator3D Model 2170	SUNW,Ultra-2	sun4u
Ultra 2 Creator Model 1200	SUNW,Ultra-2	sun4u
Ultra 2 Creator3D Model 1200	SUNW,Ultra-2	sun4u
Ultra 2 Creator Model 2200	SUNW,Ultra-2	sun4u
Ultra 2 Creator 3D Model 2200	SUNW,Ultra-2	sun4u
Ultra 2 Creator Model 1300	SUNW,Ultra-2	sun4u
Ultra 2 Creator Model 2300	SUNW,Ultra-2	sun4u
Ultra 5	SUNW,Ultra-5_10	sun4u
Ultra 10	SUNW,Ultra-5_10	sun4u
Ultra 30	SUNW,Ultra-30	sun4u
Ultra 60	SUNW,Ultra-60	sun4u
Ultra 80	SUNW,Ultra-80	sun4u
Ultra 450	SUNW,Ultra-4	sun4u
Sun Enterprise 2 Model 1170	SUNW,Ultra-2	sun4u
Sun Enterprise 2 Model 2170	SUNW,Ultra-2	sun4u
Sun Enterprise 2 Model 1200	SUNW,Ultra-2	sun4u
Sun Enterprise 2 Model 2200	SUNW,Ultra-2	sun4u
Sun Enterprise 2 Model 1300	SUNW,Ultra-2	sun4u
Sun Enterprise 2 Model 2300	SUNW,Ultra-2	sun4u
Sun Enterprise 150	SUNW,Ultra-1	sun4u
Sun Enterprise 250	SUNW,Ultra-250	sun4u
Sun Enterprise 450	SUNW,Ultra-4	sun4u
Sun Enterprise 3000	SUNW,Ultra-Enterprise	sun4u
Sun Enterprise 4000	SUNW,Ultra-Enterprise	sun4u
Sun Enterprise 5000	SUNW,Ultra-Enterprise	sun4u
Sun Enterprise 6000	SUNW,Ultra-Enterprise	sun4u
Sun Enterprise 3500	SUNW,Ultra-Enterprise	sun4u
Sun Enterprise 4500	SUNW,Ultra-Enterprise	sun4u

**TABLE 1-1** Platform Names for Sun Systems (Continued)

System	Platform Name	Platform Group
Sun Enterprise 5500	SUNW,Ultra-Enterprise	sun4u
Sun Enterprise 6500	SUNW,Ultra-Enterprise	sun4u
Sun Enterprise 10000	SUNW,Ultra-Enterprise	sun4u
SPARCserver™ 1000	SUNW,SPARCserver-1000	sun4d
SPARCcenter™ 2000	SUNW,SPARCcenter-2000	sun4d
Sun Blade™ 100	SUNW,Sun-Blade-100	sun4u
Sun Blade 1000	SUNW,Sun-Blade-1000	sun4u
Sun Fire 280R	SUNW,Sun-Fire-280R	sun4u
Sun Fire 880	SUNW,Sun-Fire-880	sun4u
Sun Fire 6800	SUNW,Sun-fire	sun4u
Sun Fire 4810	SUNW,Sun-fire	sun4u
Sun Fire 4800	SUNW,Sun-fire	sun4u
Sun Fire 3800	SUNW,Sun-fire	sun4u

Refer to the *Solaris 8 SPARC (SPARC Platform Edition) Installation Guide* manual for further information on platform groups for all other systems.

## Interactive Installation of Solaris Software

When you install the Solaris 8 4/01 operating environment from the Solaris CDs, all of the required software clusters and packages for your Sun hardware are automatically loaded. If you choose to customize your Solaris 8 4/01 software configuration using the interactive installation method, refer to TABLE 1-2 and TABLE 1-3 to identify which software packages and clusters are needed.

**TABLE 1-2** Required Software Clusters and Packages for Sun Hardware

Product Name	Cluster or Package Name	Description
S24 frame buffer	SUNWctcx	TCX API support
SX frame buffer	SUNWcsx	SX support
Creator and Creator3D	SUNWxilv1 SUNWcfb	Creator graphics device drivers and pipelines
	SUNWfbx	64-bit support

**TABLE 1-2 Required Software Clusters and Packages for Sun Hardware (Continued)**

<b>Product Name</b>	<b>Cluster or Package Name</b>	<b>Description</b>
Creator and Creator3D (Series 2)	SUNWxilv1	Creator graphics device drivers and pipelines
	SUNWCffb	
	SUNwffbx	64-bit support
Elite3D	SUNWCafb	Elite3D device drivers and pipelines
	SUNWafbm	Elite3D online manual pages
	SUNWafbx	64-bit support
PGX™ graphics frame buffer	SUNWCm64	M64 graphics support
	SUNWm64x	64-bit support
PGX32™ Graphics Frame Buffer	TSIpgx.u	Device driver for PGX32 (Raptor GFX) graphics accelerator
	TSIpgxmn	PGX32 (Raptor GFX) graphics accelerator manual pages
	TSIpgxw	X Server loadable module for PGX32 (Raptor GFX) graphics accelerator
	TSIpgxx.u	Device driver for PGX32 (Raptor GFX) graphics accelerator (64-bit)
SPARCstorage™ Array (Models 100 or 200)	SUNWssad	SPARCstorage Array support software
	SUNWssaop	
	SUNWssdx	64-bit support
Sun StorEdge™ A5000	SUNWClux	Sun StorEdge A5000 support software
	SUNWses	
	SUNWluxdx.u	64-bit support
	SUNWluxlx	
SunSwift™ SBus Adapter	SUNWChmd	SunSwift SBus adapter drivers
	SUNWhmdx	64-bit Support
SunSwift PCI Adapter	SUNWChmd	SunSwift PCI adapter drivers
	SUNWhmdx	64-bit support
SPARCstation 4	SUNWCtcx	TCX API support
SPARCstation 5	SUNWCtcx	TCX API support
SPARCstation 10SX	SUNWCsx	SX end user
SPARCstation 20	SUNWCsx	SX end user
Ultra 1 Series	SUNWxilv1	VIS/XIL support

**TABLE 1-2** Required Software Clusters and Packages for Sun Hardware *(Continued)*

<b>Product Name</b>	<b>Cluster or Package Name</b>	<b>Description</b>
Ultra 1 Creator Series, Ultra 2 Creator Series, and Sun Enterprise X000 Series	SUNWxilv1	VIS/XIL support
	SUNWCffb	Creator graphics device drivers and pipelines
	SUNWChmd	SunSwift SBus adapter drivers
	SUNWffbx SUNWhmdx	64-bit support
Ultra 5, Ultra 10, and Ultra 30	SUNWxilv1	VIS/XIL support
	SUNWCffb	Creator graphics device drivers and pipelines
	SUNWCm64	M64 graphics support
	SUNWChmd	SunSwift SBus adapter drivers
	SUNWffbx SUNWhmdx SUNWm64x	64-bit support
	Ultra 60	SUNWxilv1
SUNWCffb		Creator graphics device drivers and pipelines
SUNWCm64		M64 graphics support
SUNWChmd		SunSwift SBus adapter drivers
SUNWffbx SUNWm64x		64-bit support
Ultra 450 and Sun Enterprise 450	SUNWCpd	Drivers for SPARC platforms with PCI bus
	SUNWpdx	64-bit support
Sun Enterprise 10000	SUNWC4u1	Sun Enterprise 10000 support
	SUNWcvcx	64-bit support
Sun Blade 100 and Sun Blade 1000	SUNWpiclh SUNWpiclr SUNWpiclu SUNWpiclx	PICL
	SUNW1394h SUNW1394x	IEEE framework (1394)
	SUNWeridx	RIO driver
	SUNWusx.u	CPU power management's UltraSPARC driver

**TABLE 1-2** Required Software Clusters and Packages for Sun Hardware *(Continued)*

<b>Product Name</b>	<b>Cluster or Package Name</b>	<b>Description</b>
Sun Fire 280R	SUNWcarx.u SUNWhea SUNWkvm.u SUNWkvmx.u SUNWmdb SUNWpiclu SUNWpstl.u SUNWpstlx.u	
Expert3D	SUNWfbc SUNWifb.u SUNWifbcf SUNWifbr SUNWifbw SUNWifbx.u	Expert3D packages
Sun Fire 880	SUNWpiclh SUNWpiclr SUNWpiclu SUNWpiclx SUNWeridx SUNWqlc SUNWqlcx	PICL    RIO driver FC-AL
Sun Fire 6800, 4810, 4800, 3800	SUNWcarx.u SUNWhea SUNWkvm.u SUNWkvmx.u SUNWmdb SUNWpstl.u SUNWpstlx.u	

# Manual Installation of Packages

If you are installing at the package level, refer to TABLE 1-3 for the software packages required for specific hardware.

**TABLE 1-3** Required Packages for Hardware Platforms and Options

<b>Product Name</b>	<b>Package Name</b>
SX frame buffer	SUNWsxr.m SUNWsx SUNWsxow SUNWxilcg SUNWsxzgl
S24 or FSV frame buffer	SUNWtcx.m SUNWtcxu SUNWtcxow
Creator and Creator3D (including Series 2)	SUNWffb.u SUNWffbcf SUNWffbw SUNWffbxg SUNWxilvl
Elite3D	SUNWafb.u SUNWafbcf SUNWafbmn SUNWafbr SUNWafbw SUNWafbxg
Expert3D	SUNWfbc SUNWifb.u SUNWifbcf SUNWifbr SUNWifbw SUNWifbx.u
PGX Graphics Frame Buffer	SUNWm64.u SUNWm64w SUNWm64cf
PGX32 Graphics Frame Buffer	TSICpgx.u TSIpgxmn TSIpgxw TSIpgxx.u
SunSwift SBus Adapter	SUNWhmd SUNWhmdu
SunSwift PCI Adapter	SUNWhmd SUNWhmdu



**TABLE 1-3** Required Packages for Hardware Platforms and Options *(Continued)*

<b>Product Name</b>	<b>Package Name</b>
SPARCstorage Array, model 100/200	SUNWssad SUNWssaop
Sun StorEdge A5000	SUNWluxal SUNWluxdv.d SUNWluxdv.u SUNWluxdv.u1 SUNWluxmn SUNWluxop SUNWses
Ultra 1 Series	SUNWxilv1
Ultra 1 Creator Series, Ultra 2 Creator Series, Ultra 5, Ultra 10, Ultra 60, Ultra 80, Sun Blade 100, Sun Blade 1000 or Sun Enterprise X000 Series	SUNWffb.u SUNWffbcf SUNWffbw SUNWffbxg SUNWxilv1 SUNWhmd SUNWhmdu
Ultra 5, Ultra 10, Ultra 60, Ultra 80, Ultra 250, Ultra 450, Sun Blade 100, Sun Blade 1000, and Sun Enterprise 450	SUNWpd SUNWpdu
Sun Enterprise 10000	SUNWcvcr.u
Sun Blade 100 and Sun Blade 1000	SUNWpiclh SUNWpiclr SUNWpiclu SUNWpiclx SUNW1394h SUNW1394x SUNWeridx SUNWusx.u

**TABLE 1-3** Required Packages for Hardware Platforms and Options *(Continued)*

<b>Product Name</b>	<b>Package Name</b>
Sun Fire 280R	SUNWcarx.u
	SUNWhea
	SUNWkvm.u
	SUNWkvmx.u
	SUNWmdb
	SUNWpiclu
	SUNWpstl.u
SUNWpstlx.u	
Sun Fire 880	SUNWpiclh
	SUNWpiclr
	SUNWpiclu
	SUNWpiclx
	SUNWeridx
	SUNWqlc
	SUNWqlcx
Sun Fire 6800, 4810, 4800, 3800	SUNWcarx.u
	SUNWhea
	SUNWkvm.u
	SUNWkvmx.u
	SUNWmdb
	SUNWpstl.u
SUNWpstlx.u	

---

## Custom JumpStart Profiles

For information on the availability of the custom JumpStart method at your site, consult your system administrator. TABLE 1-4 lists platforms and hardware and software options that may require additional entries in custom profiles. These clusters might not be installed with the core distribution software group. Refer to the *Solaris 8 (SPARC Platform Edition) Installation Guide* manual for more information.

When writing custom JumpStart profiles, be sure to allow sufficient space in the root partition for software from the Supplement CD, such as software for SunVTS diagnostics.

---

**Note** – For more information about automating Solaris installations, refer to *Automating Solaris Installations: A Custom JumpStart Guide* (Kasper/McClellan), a SunSoft™ Press/Prentice Hall publication.

---

**TABLE 1-4** Additional Entries for Custom JumpStart Installations

<b>Product Name</b>	<b>Package Name</b>
SX Frame Buffer	cluster SUNWCsx
S24 or FSV Frame Buffer	cluster SUNWCtcx
Creator and Creator3D Graphics (including Series 2)	cluster SUNWCffb package SUNWxilvl
Elite3D	cluster SUNWCafb package SUNWafbmn
PGX Graphics Frame Buffer	cluster SUNWCm64
PGX32 Graphics Frame Buffer	TSIpgx TSIpgxmn TSIpgxx.u
SunSwift SBus Adapter	cluster SUNWChmd
SunSwift PCI Adapter	cluster SUNWChmd
SPARCstation 10SX	cluster SUNWCsx
SPARCstation 20	cluster SUNWCsx
Ultra 5, Ultra 10, Ultra 60, Ultra 80, Ultra 250, Ultra 450, Sun Enterprise 450, Sun Blade 100, and Sun Blade 1000	cluster SUNWCpd
Sun Enterprise 10000	cluster SUNWC4u1
Expert3D	SUNwifbc SUNwifb.u SUNwifbcf SUNwifbr SUNwifbw SUNwifbx.u
Sun Blade 100 and Sun Blade 1000	SUNWpiclh SUNWpiclr SUNWpiclu SUNWpiclx SUNW1394h SUNW1394x SUNWeridx SUNWusx.u

---

**TABLE 1-4** Additional Entries for Custom JumpStart Installations

<b>Product Name</b>	<b>Package Name</b>
Sun Fire 280R	SUNWcarx.u
	SUNWhea
	SUNWkvm.u
	SUNWkvmx.u
	SUNWmdb
	SUNWpiclu
	SUNWpstl.u
Sun Fire 880	SUNWpiclh
	SUNWpiclr
	SUNWpiclu
	SUNWpiclx
	SUNWeridx
	SUNWqlc
	SUNWqlcx
Sun Fire 6800, 4810, 4800, 3800	SUNWcarx.u
	SUNWhea
	SUNWkvm.u
	SUNWkvmx.u
	SUNWmdb
	SUNWpstl.u
	SUNWpstlx.u

---

## 32-bit Kernel—Default on 200MHz or Lower UltraSPARC Systems

On UltraSPARC systems with 200MHz or lower processors, it is possible for a user to run a 64-bit program designed to exploit a problem that could cause a processor to stall. Since 64-bit programs cannot run on the Solaris 32-bit kernel, the Solaris 32-bit kernel is booted by default on these systems.

The code sequence that exploits the problem is very unusual, and is not likely to be generated by a compiler. Assembler code had to be specifically written to demonstrate the problem. It is highly unlikely that a legitimate handwritten assembler routine would use this code sequence.

Users willing to assume the risk that a user might accidentally or deliberately run a program that was designed to cause a processor to stall may choose to run the Solaris 64-bit kernel on these systems.

You can determine the speed of your processor(s) by typing:

```
# /usr/sbin/psrinfo -v
```

You can change the default kernel from 32-bit on a system by modifying the boot policy file. Edit the `/platform/platform-name/boot.conf` file so that it contains an uncommented line with the variable named `ALLOW_64BIT_KERNEL_ON_UltraSPARC_1_CPU` set to the value `true` as shown in the example that follows:

```
ALLOW_64BIT_KERNEL_ON_UltraSPARC_1_CPU=true
```

See `boot(1M)` for more information about changing the default kernel.

You may also purchase an upgrade to your system, contact your Sun representative for details.



# Supported Sun Hardware

---

---

## Supported Platforms

The following Sun systems are supported in the Solaris 8 4/01 release:

- SPARCclassic
- SPARCstation LX
- SPARCstation 4
- SPARCstation 5
- SPARCstation 5 Model 170
- SPARCstation 10
- SPARCstation 10SX
- SPARCstation 20
- SPARCstation 20 Model HS11, HS12, HS14, HS21, HS22, 151, and 152
- Ultra 1 Model 140, 170
- Ultra 1 Creator Model 140E, 170E, 200E
- Ultra 1 Creator3D Model 140E, 170E, 200E
- Sun Enterprise 1 Model 140, 170, 170E
- Ultra 2 Creator Model 1170, 2170, 1200, 2200, 1300, 2300
- Ultra 2 Creator3D Model 1170, 2170, 1200, 2200
- Ultra 5
- Ultra 10
- Ultra 30
- Ultra 60
- Ultra 80
- Ultra 450
- Sun Enterprise 2 Model 1170, 2170, 1200, 2200, 1300, 2300

- Sun Enterprise 150
- Sun Enterprise 220R
- Sun Enterprise 250
- Sun Enterprise 420R
- Sun Enterprise 450
- Sun Enterprise 3000
- Sun Enterprise 4000
- Sun Enterprise 5000
- Sun Enterprise 6000
- Sun Enterprise 3500
- Sun Enterprise 4500
- Sun Enterprise 5500
- Sun Enterprise 6500
- Sun Enterprise 10000
- SPARCserver 1000 and 1000E
- SPARCcenter 2000 and 2000E
- Sun Blade 100
- Sun Blade 1000
- Sun Fire 280R
- Sun Fire 880
- Sun Fire 6800
- Sun Fire 4810
- Sun Fire 4800
- Sun Fire 3800

The following Sun Microelectronics motherboards are supported in the Solaris 8 4/01 release:

- CP1500-270
- CP1500-333
- CP1500-360
- CP1500-440
- CP1400-300
- CP1200
- Ultra AX
- Ultra AXi
- Ultra AXdp
- Ultra AXmp
- Ultra AXmp+
- Ultra AXe



# Installing Software from the Software Supplement for the Solaris 8 Operating Environment 4/01 CD

---

This chapter describes the contents of the software on the CD labeled Software Supplement for The Solaris 8 Operating Environment 4/01. This CD is referred to in this document as the Supplement CD. The Supplement CD contains software for these Sun products:

- SunVTST<sup>™</sup> 4.3 diagnostic software
- OpenGL<sup>®</sup> 1.2.1 software
- PC launcher/PC file viewer 1.0.1/1.0.1 software
- ShowMe TV<sup>™</sup> 1.3 software
- Sun hardware manual pages
- Solaris 8 4/01 AnswerBook2<sup>™</sup> Set
- SunFDDI<sup>™</sup> PCI 3.0 driver
- SunFDDI SBus 7.0 driver
- SunHSI<sup>™</sup> PCI 3.0 driver
- SunHSI SBus 3.0 driver
- SunATM<sup>™</sup> 5.0 driver
- SunForum<sup>™</sup> 3.1 software
- Remote System Control (RSC) 2.1 for Sun Enterprise servers
- Java 3D<sup>™</sup> 1.2 software
- Sun Enterprise 10000 System Service Processor (SSP) 3.4 software
- Sun Enterprise 10000 System Service Processor (SSP) 3.4 AnswerBook
- Sun Enterprise 10000 Capacity on Demand 1.0 software
- Sun Enterprise 10000 Capacity on Demand 1.0 AnswerBook
- Sun Enterprise Server Alternate Pathing 2.3.1 (AP) software

The following table lists the versions of the software in the current Solaris 8 update release as well as the versions in the preceding Solaris 8 releases.

**TABLE 3-1** Solaris 8 Supplement CD Content

Software	Solaris 8	Solaris 8 6/00	Solaris 8 10/00	Solaris 8 1/01	Solaris 8 4/01
Alternate Pathing	2.3	2.3	2.3	2.3.1	2.3.1
CDRW	n/a	n/a	1.0	1.0	1.0
Capacity on Demand	1.0	1.0	1.0	1.0	1.0
Java 3D	1.1.2	1.1.2	1.1.2	1.1.2	1.2
Netra™ ct Platform	n/a	1.0	1.0	1.0	1.0
Netra t11xx Alarms	n/a	n/a	2.0	2.0	2.0
Netra Lights Out Management	n/a	n/a	1.0	2.0	2.0
OpenGL	1.2.1	1.2.1	1.2.1	1.2.1	1.2.1
PC launcher, PC file viewer	1.0.1, 1.0.1	1.0.1, 1.0.1	1.0.1, 1.0.1	1.0.1, 1.0.1	1.0.1, 1.0.1
RSC	1.0	1.0	1.0	2.0	2.1
ShowMe TV	1.3	1.3	1.3	1.3	1.3
SunATM	5.0	5.0	5.0	5.0	5.0
SunFDDI PCI	3.0	3.0	3.0	3.0	3.0
SunFDDI SBus	7.0	7.0	7.0	7.0	7.0
SunForum	3.0	3.0	3.0	3.1	3.1
SunHSI PCI	3.0	3.0	3.0	3.0	3.0
SunHSI SBus	3.0	3.0	3.0	3.0	3.0
SunVTS	4.0	4.0	4.1	4.2	4.3
Sun Enterprise 10000 System Service Processor	3.2	3.3	3.3	3.4	3.4

## Installing Supplement CD Software

There are at least two ways to install software from the Supplement CD:

- Solaris Web Start 2.0
- pkgadd

# Before Installing Supplement CD Software

If you have installed any of the Supplement CD software from a previous release, you should remove the packages associated with that software before installing the new software.

## Installing Supplement CD Software Using Solaris Web Start 2.0

You can use Solaris Web Start 2.0 to install Supplement CD software after you have installed the Solaris operating environment.

### ▼ To Install Supplement CD Software Using Solaris Web Start 2.0

1. Insert the Supplement CD into your CD ROM drive.
2. In a shell, type:

```
# cd /cdrom/cdrom0
# ./installer
```

3. When the Solaris Web Start GUI is displayed, select Next.
4. See TABLE 3-2 on page 19. In the Solaris Web Start 2.0 column, software is labeled “Installed by default” or “Optional”.
  - a. If you want to install all of the default installed software, click Default Install, then click Next.
  - b. If you only want to install some of the software products, click Custom Install, then click Next. Select the software you want to install, then click Next.

TABLE 3-2 Supplement Software Installation

Software	Solaris Web Start 2.0
SunVTS 4.3 software	Installed by default
OpenGL 1.2.1 software	Installed by default
PC launcher and PC file viewer software	Installed by default
ShowMe TV 1.3 software	Installed by default
Solaris on Sun Hardware AnswerBook2 Set	Installed by default

**TABLE 3-2** Supplement Software Installation (*Continued*)

<b>Software</b>	<b>Solaris Web Start 2.0</b>
SunFDDI drivers	Installed by default
SunHSI drivers	Installed by default
SunATM driver	Installed by default
SunForum software	Installed by default
Java 3D 1.2 software	Installed by default
Remote System Control 2.1 (RSC) for Sun Enterprise Servers	Installed by default
CDRW 1.0 software	Installed by default
Sun Enterprise 10000 SSP 3.4 software	Optional
Alternate Pathing 2.3.1 software	Optional
Capacity On Demand (COD) 1.0 software	Optional
Netra ct Platform software	Optional
Netra t11 Alarms software	Optional
Netra Lights Out Management software	Optional

## Installing Supplement CD Software on a Standalone System Using `pkgadd`

- ▼ To install packages for supported products from the Supplement CD using `pkgadd`

- 1. Insert the Supplement CD into your CD-ROM drive.**

The File Manager window is displayed.

- 2. In a shell, become superuser using the `su` command and the superuser password.**

- 3. Type:**

```
# /usr/sbin/pkgadd -d /cdrom/cdrom0/directory/Product package_names
```

or:

```
# cd /cdrom/cdrom0/directory/Product  
# pkdadd -d . package_names
```

where *directory* is the software product directory from TABLE 3-3 and *package\_names* are the package names from TABLE 3-3.

The argument to the `-d` option must be a full path name to a device or directory. If you do not specify the device on which the package resides, `pkgadd` checks the default spool directory (`/var/spool/pkg`). If the package is not there, installation fails.

To install a particular product, choose the appropriate packages:

**TABLE 3-3** Software and Packages

Software	Version	Directory	Packages
Validation Test Suite Software (SunVTS)	4.3	SunVTS_4.3/	SUNWvts SUNWvtsmn SUNWvtsx SUNWvtsol
OpenGL Runtime Libraries	1.2.1	OpenGL_1.2.1/	SUNWafbgl SUNWafbgx SUNWffbgl SUNWffbgx SUNWifbgl SUNWifbgx SUNWglh SUNWglrt SUNWglrtu SUNWglrtx SUNWglsr SUNWglsrx SUNWglsrz
PClauncher/PC file viewer	1.0.1/ 1.0.1	PC_launcher_1.0.1_PC_fileviewer_1.0.1/	SUNWdtpcv SUNWdtpcz SUNWdtpcp
Remote System Control Server	2.1	RSC_2.1/	SUNWrsc SUNWrscd SUNWrscj
ShowMe TV	1.3	ShowMeTV_1.3/	SUNWsmtvh SUNWsmtvr SUNWsmtvt SUNWsmtvu
SunForum	3.1	SunForum_3.1	SUNWdat SUNWdatu
SunFDDI PCI driver	3.0	SunFDDI_PCI_3.0/	SUNWpfd SUNWpfh SUNWpfm SUNWpfu

**TABLE 3-3** Software and Packages (Continued)

Software	Version	Directory	Packages
SunFDDI SBus driver	7.0	SunFDDI_SBus_7.0/	SUNWnfd SUNWnfh SUNWnfm SUNWnfu
SunHSI PCI driver	3.0	SunHSI_PCI_3.0/	SUNWhsip SUNWhsipm SUNWhsipu
SunHSI SBus driver	3.0	SunHSI_SBus_3.0/	SUNWhsis SUNWhsism SUNWhsisu
Sun Hardware AnswerBook2	1.0	Sun_Hardware_Answerbook/	SUNWabhdw
Java 3D	1.2	Java3D_1.2/	SUNWj3doc SUNWj3dem SUNWj3drt SUNWj3dut
SunATM 5.0	5.0	SunATM_5.0/	SUNWatm SUNWatma SUNWatmu
Alternate Pathing	2.3.1	Alternate_Pathing_2.3.1/	SUNWapdoc SUNWapdv SUNWapr SUNWapu SUNWabap
Sun Enterprise 10000 SSP	3.4	System_Service_Processor_3.4/	SUNWsspfd SUNWsspdo SUNWsspdr SUNWsspfp SUNWsspfd SUNWsspdmn SUNWsspob SUNWsspop SUNWssppo SUNWsspr SUNWsspst SUNWsspue SUNWuessp
Sun Enterprise 10000 Capacity On Demand (COD) software and AnswerBook	1.0	Capacity_on_Demand_1.0/	SUNWcod SUNWcodbk SUNWcodmn

**TABLE 3-3** Software and Packages (*Continued*)

Software	Version	Directory	Packages
Netra ct Platform software	1.0	Netra_ct_Platform_1.0/	SUNW2jdrt SUNWctac SUNWcteux SUNWctevx SUNWctmgx
Netra t11 Alarms software	2.0	Netra_t11xx_Alarms_2.0/	SUNWtsalm SUNWtsalr SUNWtsalu
Netra Lights Out Management software	2.0	Netra_Lights_Out_Management_2.0/	SUNWlomm SUNWlomr SUNWlomu
CDRW	1.0	CDRW_1.0	SUNWcdrw

If a problem occurs during package installation, information about the problem is displayed, followed by this prompt:

```
Do you want to continue with this installation?
```

Respond with either *yes*, *no*, or *quit*.

## Validation Test Suite Software (SunVTS Software)

The SunVTS validation test suite is a diagnostic tool designed to test Sun hardware. By running multiple diagnostic hardware tests, the SunVTS software verifies the connectivity and functionality of most SPARC hardware controllers and devices in a 32-bit or 64-bit Solaris operating environment.

SunVTS provides an infrastructure for programmers to develop their own tests and run them using the SunVTS interface.

You can find the software for the SunVTS application on the Supplement CD. To use the SunVTS software, refer to the *SunVTS 4.3 User's Guide*, the *SunVTS 4.3 Test Reference Manual*, and the *SunVTS Quick Reference Card*.

TABLE 3-4 describes the main features of the SunVTS environment.

**TABLE 3-4** SunVTS Diagnostic Tool Features

Feature	Description
SunVTS kernel ( <i>vtstk</i> )	The SunVTS kernel controls all aspects of the testing. It is a daemon designed to stay in the background, and to be used when needed. Upon starting, the SunVTS kernel probes the hardware configuration of the system under test and waits for instructions from a SunVTS user interface. During testing, the SunVTS kernel coordinates the running of individual tests, and manages all the messages (informational and error messages) sent by these tests.
SunVTS CDE user interface ( <i>vtsui</i> )	This interface is designed to run on top of the Common Desktop Environment (CDE). This user interface provides the means to configure, run, and monitor SunVTS test sessions for local and remote hosts.
SunVTS OPEN LOOK user interface ( <i>vtsui.o1</i> )	This interface is designed to be run on top of OpenWindows. The SunVTS OPEN LOOK user interface does not support the latest SunVTS features. For full feature support, use the SunVTS CDE or TTY interface. The SunVTS OPEN LOOK user interface will be sustained, but not enhanced, as long as OPEN LOOK is supported in the Solaris environment.
SunVTS TTY user interface ( <i>vtstty</i> )	Because not every system has a monitor, SunVTS has a TTY interface. This ASCII menu-based interface accepts various key sequences to control the test options and the test sessions. It can be used from a terminal, a shell tool, or a remote login session through a modem.
Running an individual test from the command line	Besides being run from a SunVTS user interface, each individual hardware test can be run from a UNIX® command line. Running a test alone can be helpful to validate only one piece of hardware.
Custom test support	A SunVTS user can run third-party executable test binaries under the SunVTS environment in the way that the test, rather than the SunVTS kernel, fully controls its input argument list and output log files. A user can simply modify the <i>.customtest</i> file provided by SunVTS to make it loosely coupled to the environment.



# SunVTS Packages

TABLE 3-5 provides a list of SunVTS packages needed to run the SunVTS diagnostic tool.

**TABLE 3-5** SunVTS Packages on the Supplement CD

Includes Packages	Name	Description
SUNWvts	Validation Test Suite	SunVTS kernel, user interface (UI), tests and tools
SUNWvtsmn	Validation Test Suite Manual Pages	Manual pages for SunVTS utilities/binaries
SUNWvtsx	Validation Test Suite	64-Bit Validation Test Suite software
SUNWvtsol	SunVTS OPEN LOOK UI, Sundials and Sunbuttons tests	Contains the SunVTS OPEN LOOK UI and OPEN LOOK dependent tests. Prior to SunVTS 4.1, these components were part of the SUNWvts package.

## Installing SunVTS

See “Installing Supplement CD Software” on page 18.

## Using SunVTS Software

To use SunVTS software, refer to the *SunVTS 4.3 User's Guide* in the Solaris 8 4/01 on Sun Hardware AnswerBook set. For SunVTS test and quick reference information, refer to the *SunVTS 4.3 Test Reference Manual* and *SunVTS Quick Reference Card*.

---

## OpenGL Software

The Sun OpenGL software for Solaris is the Sun native implementation of the OpenGL application programming interface (API). The OpenGL API is an industry-standard, vendor-neutral graphics library. It provides a small set of low-level geometric primitives and many basic and advanced 3D rendering features, such as modeling transformations, shading, lighting, anti-aliasing, texture mapping, fog, and alpha blending.

# Supported Platforms

The Sun OpenGL 1.2.1 software for Solaris supports the following devices:

- Creator Graphics, Creator3D Graphics, Elite3D Graphics, and Expert3D Graphics—OpenGL functionality is accelerated in hardware.
- SX, GX, GX+, TGX, TGX+, S24—OpenGL functionality is performed in software.
- All Sun SPARC systems equipped with the following frame buffers are supported on the OpenGL 1.2.1 software: the TCX, SX, GX, Creator, Elite3D, and Expert3D families of frame buffers. This includes Ultra desktop, Sun Enterprise, and all the legacy SPARCstation family.

## Removing Old Packages

If you have older versions of the Sun OpenGL software for Solaris packages, you must use the `pkgrm` command to remove them.

### ▼ To Remove Old Packages

1. **Check to see whether any older versions of the OpenGL packages are installed using the `pkginfo` command.**

The `pkginfo | egrep -i "OpenGL"` command lists any existing OpenGL packages that you have installed.

```
% pkginfo | egrep -i "OpenGL"
application SUNWffbgl      Creator Graphics (FFB) OpenGL Support
application SUNWglrt      OpenGL Runtime Libraries
application SUNWglrtu     OpenGL Platform Specific Runtime Libraries
application SUNWglwrt     OpenGL Widget Library
application SUNWafbgl     Loadable pipeline for UPA Bus Elite3D graphics
application SUNWgldoc     Solaris OpenGL Documentation and Man Pages
application SUNWglh       Solaris OpenGL Header Files
application SUNWglut      Solaris OpenGL Utilities and Example Programs
application SUNWglwh      Solaris OpenGL Widget Header Files
```

2. **To remove the packages, become superuser:**

```
% su
Password: superuser password
```

### 3. Run `pkgrm` to remove all existing Sun OpenGL software for Solaris packages.

```
# pkgrm SUNWglrt SUNWglh...
```

## OpenGL Packages

TABLE 3-6 lists the packages that are provided with the Sun OpenGL software for Solaris.

TABLE 3-6 OpenGL Packages

Package Name	Description	Default Install Location
SUNWglh	OpenGL header files	/usr
SUNWglrt	OpenGL client-side runtime libraries	/usr/openwin/lib
SUNWglshr	OpenGL generic SPARC software renderer	/usr/openwin/lib
SUNWglrtu	OpenGL libraries specific to UltraSPARC™	/usr/openwin/platform/sun4u/lib/GL
SUNWglsrz	OpenGL UltraSPARC software renderer	/usr/openwin/platform/sun4u/lib/GL
SUNWafbg1	OpenGL device pipeline for Elite3D graphics accelerators	/usr/openwin/lib/GL/devhandlers
SUNWffbg1	OpenGL device pipeline for Creator and Creator3D graphics accelerators	/usr/openwin/lib/GL/devhandlers
SUNWifbg1	OpenGL device pipeline for Expert3D graphics accelerator	/usr/openwin/lib/GL/devhandlers
SUNWglrtx	Sun OpenGL 64-bit Runtime Libraries	/usr/openwin
SUNWglsrx	OpenGL 64-bit UltraSPARC software renderer	/usr/openwin/platform/sun4u/lib/sparcv9/GL
SUNWafbgx	OpenGL 64-bit device pipeline for Elite3D graphics accelerator	/usr/openwin/lib/sparcv9/GL/devhandlers
SUNWffbgx	OpenGL 64-bit device pipeline for Creator and Creator3D graphics accelerators	/usr/openwin/lib/sparcv9/GL/devhandlers
SUNWifbgx	OpenGL 64-bit device pipeline for Expert3D graphics accelerator	/usr/openwin/lib/sparcv9/GL/devhandlers

# Installing OpenGL

See “Installing Supplement CD Software” on page 18.

## After Installing the Packages

After installing the packages, do the following:

### ▼ To Verify Package Installation

**1. Exit the window system and restart it so that the window system loads the newly installed GLX server extension.**

**2. To verify that the OpenGL libraries are installed correctly, run**

`ogl_install_check`.

The `ogl_install_check` test program prints the version of the OpenGL library and renderer used, and renders a rotating wheel. The program returns the following output when it is run on an UltraSPARC Creator3D:

```
OpenGL Vendor:           Sun Microsystems, Inc.
OpenGL Version:         1.2.1 Sun OpenGL 1.2.1 for Solaris
```

For diagnostic purposes, the following values should be noted if Solaris OpenGL software problems are seen:

```
OpenGL Renderer:        Creator 3D, VIS
OpenGL Extension Support:
                        GL_EXT_texture3D
                        GL_SGI_color_table
                        GL_SUN_geometry_compression
                        GL_EXT_abgr
                        GL_EXT_rescale_normal
OpenGL GLX Server:      Detail Status Report
  GLX:                   Context is direct.
  GLX:                   OpenGL Rendering in use
  GLX:                   Double Buffering in use
  GLX:                   Color Buffer (GLX_BUFFER_SIZE) = 24 bits
  GLX:                   Depth Buffer (GLX_DEPTH_SIZE) = 28 bits
  GLX:                   Stencil Buffer (GLX_STENCIL_SIZE) = 4 bits
  GLX:                   RGBA (True Color/Direct Color) Visual in use
OpenGL Library:         Detail Status Report
  Number of color bits (R/G/B/A): 8/8/8/0
  Frame Buffer Depth (GL_DEPTH_BITS):28
```

# Unexpected Slow Local Rendering

Whenever possible, Sun OpenGL software for Solaris renders directly to the frame buffer, bypassing the X server. This is enabled by Sun's DGA mechanism for locking portions of the screen. However, a Solaris security feature only allows the user who originally logged in to the window system to use DGA to lock portions of the screen. Only owners of the window system have access to DGA.

If you notice poor performance when rendering locally, the cause may be this Solaris security feature. For example, if you start the window system, and another user at the workstation changes to that user's own environment using `su`, the application will not run via DGA even though the second user is running the application locally.

If you notice slow local rendering, run the `ogl_install_check` diagnostic program (found in `/usr/openwin/demo/GL`) to determine whether the application is running via DGA. If the OpenGL GLX server status report from the `ogl_install_check` program says that the GLX context is indirect, edit the login permissions to enable DGA access for all users.

To give all local users access to DGA, follow these steps:

## ▼ To Give All Local Users Access to DGA

### 1. Become superuser:

```
% su  
Password: superuser password
```

### 2. Edit permissions to allow world read/write access to the following devices:

```
% chmod 666 /dev/mouse /dev/kbd /dev/sound/* /dev/fbs/*
```

This enables DGA access for all users for the duration of the current window system session (subject to X authorization, see `xhost(1)`).

**3. Edit the `/etc/logindevperm` file and change the default permissions of all devices listed in the file to `0666` to allow world read/write access.**

For example, in the following lines in `logindevperm`, change `0600` to `0666` so that the next time you log in and restart your window system, it will still be accessible by all users.

```
/dev/console    0600    /dev/mouse:/dev/kbd
/dev/console    0600    /dev/sound/*      # audio devices
/dev/console    0600    /dev/fbs/*        #frame buffers
```

Note that your system is no longer secure.

---

## PC Launcher

### Audience

PC launcher is designed for Solaris users who have access to Windows '98, ME, NT, or 2000 based PC environments

### What is PC Launcher?

PC launcher provides you with the capability to view and edit PC files and attachments by launching the associated Windows applications and files in the PC environment. PC launcher enables you to launch attachments and files created in the Windows environment.

### PC Launcher Installation Requirements

- Software Supplement for The Solaris 8 Operating Environment 4/01 CD

If you don't have the Supplement CD, contact your Sun service representative.

# System Requirements

## Sun Workstation

- Solaris 8 4/01 operating environment
- CDE 1.3
- 32 MB RAM

## Network PC Environment with one of the following:

- SunPCi™ card
- Software environment
- PC Hardware with Windows '98, ME, NT, or 2000 (PCNFS™/Solstice™ Network Client)

## PC Launcher Installation

### SunPCi Requirements

In order for PC launcher to work, SunPCi and its host workstation must be able to ping each other by 'name'. To do this, you must have:

- IP connectivity between the two.
- Name services (whatever you happen to be using) set up on each so that you can look up the other's name and get its IP address.

Because of the network architecture of SunPCi and the way it shares Ethernet access with its host, the SunPCi and host cannot see each other on the network.

To work around this, use an IP routing system (a "real" router, another Sun system, an NT system, etc.) on the same subnet to act as a proxy router.

---

**Note** – You must have account access to the IP router you have selected, since you must add two routes to it.

---

For example, based on following setup:

- SunPCi IP = 10.0.0.1
- Host workstation IP = 10.0.0.2
- Router IP = 10.0.0.3

you need to do the following:

**1. On the host workstation:**

```
route add 10.0.0.1 10.0.0.3 1
```

---

**Note** – You can add an `/etc/rc` script to make this happen at every reboot.

---

**2. On the routing proxy:**

```
route add 10.0.0.2 10.0.0.3 0
```

```
route add 10.0.0.1 10.0.0.3 0 (or the equivalent)
```



---

**Caution** – You must add routes to all three systems in this fashion in order for this to work. Do *NOT* assume that "standard network default routers" or anything else will provide similar functionality; they will not.

---

After doing this, verify that the SunPCi can ping its host by IP, and vice versa. Once that works, make sure the systems can ping each other by name; add entries to the appropriate naming services if they cannot. On UNIX, examples of naming services are DNS or `/etc/hosts`. Windows can use DNS or the hosts file as well. Consult your system administrator to add these entries, based on your setup. Once the systems can ping each other by name, PC launcher installs.

For further assistance with installation of SunPCi, refer to the following publications:

- *SunPCi Installation Guide*
- *SunPCi Release Notes*
- *SunPCi 2.1 Windows NT Installation Guide*

## Installing PC Launcher Packages

See "Installing Supplement CD Software" on page 18.

## Configuring PC Launcher

You configure PC launcher by specifying your setup in the three steps on the PC launcher Configuration window.

Before configuring, you must have the following:

- A network host name and network connectivity between your Solaris and Windows environments.



- Your UNIX home directory mapped in your Windows environment.

## ▼ To Configure PC Launcher for PCi

1. From the CDE Toolbar, start the Application Manager.
2. Click **Configure PC launcher** under the Desktop controls. The **PC launcher Configuration window** is displayed. Answer the questions in the following three steps.
  - a. **On-Board PC Emulator and SunPCI (default)**
  - b. **Enter your Sun PCi's hostname (default)**
  - c. **Let PC Emulator handle the file**
3. Click **OK**.

---

**Note** – PC-type documents can be opened for viewing and editing through the Sun PCi card whenever you double-click a document. If you want to do “quick” viewing, select **Let Solaris handle the file** and PC file viewer is invoked. For editing, use the right-mouse button and select **Open In Emulator**.

---

4. From **SunPCi**, run `h: \.dt\bin\win9x\intel\sdtppactiond.exe`. **This step assumes h: is mapped to your UNIX home directory.**

## ▼ To Configure PC Launcher for the Software Environment

1. From the CDE toolbar, start the Application Manager.
2. Click **Configure PC launcher** under the Desktop controls then select or enter the following:
  - a. **On-Board PC Emulator and SoftWindows.**
  - b. *Hostname*
  - c. **Let Solaris handle the file**

---

**Note** – PC-type documents can be opened for viewing and editing with a right-mouse double-click. If you selected “Let Solaris handle the file” when you configured PC launcher, then double-clicking on a file will launch PC file viewer.

---

3. Click **OK**.

#### 4. From the software environment run:

```
h: \.dt\bin\win9x\intel\sdtppactiond.exe
```

This step assumes `h:` is mapped to your UNIX home directory.

### ▼ To Configure PC Launcher for a Deskside PC

1. From the CDE toolbar, start the Application Manager.
2. Click **Configure PC launcher** under the **Desktop Applications** then select or enter the following:
  - a. **Standalone PC**
  - b. *Hostname*
  - c. **Let the Standalone PC handle the file**

---

**Note** – PC-type documents can be opened for viewing and editing with a right-mouse double-click. If you selected Let Solaris handle the file when you configured PC launcher, then double-clicking on a file will launch PC file viewer.

---

3. Click **OK**.
4. From **Deskside PC** run:

```
h: \.dt\bin\win9x\intel\sdtppactiond.exe
```

This step assumes `h:` is mapped to your UNIX home directory.

## Using PC Launcher

The CDE front panel and CDE workspace can be populated with an icon representing the PC environment, such as SunPCi. To do this, drag and drop **OpenInSunPCi** from the **Desktop Applications** in **Application Manager**, onto the **Front Panel**.

If you did not configure PC launcher, then the first time you open PC launcher, the PC launcher Configuration window will display. This is where you will configure PC launcher. You only need to configure PC launcher once.

# Working With Windows Files

Identification of many popular PC file formats in CDE allows you to select and launch them in your preferred PC environment, such as SunPCi. A right mouse click on these files gives you the three following choices in the menu:

- **Open**—the double-click action.
- **OpenInEmulator**—launches the file in your preferred hardware, such as SunPCi (or any software emulator).
- **OpenInRemotePC**—launches the file in a standalone networked PC.

You can drag and drop Windows shortcuts onto the front panel. You can also put shortcuts on the CDE workspace by creating a windows short cut in your UNIX home directory and using `dtfile` to drag and drop. Refer to Windows help on creating shortcuts, and CDE help to get more information on drag and drop.

## ▼ To Open an Application or Datafile

- **Double-click on the shortcut from the Solaris desktop.**

The associated applications must be available to you. This procedure makes the Solaris desktop act like a Windows desktop. You can keep all your relevant applications inside the Solaris CDE front panel and CDE workspace and run them by double-clicking on them.

## ▼ To Run Windows Binary Files

- **Double-click on the file (.exe) and run inside the PC environment (for example, SunPCi).**

## ▼ To Copy and Paste Text

1. **Highlight the text you want to copy and select Copy from the Edit menu.**
2. **Click the place you want to paste the text, and select Paste from the Edit menu.**

## ▼ To View a File

- **Click on the file and select View.**

## ▼ To Search for a File

1. **Select Find/Change from the Edit menu.**
2. **Enter the filename into the Find field and click Find.**

## ▼ To Print Files

- **Select Print from the File menu**

The file prints out on the PC printer.

## Other Features

### ▼ To Display the Windows Start Menu in CDE

Using manual steps, you can get to all of the Windows Start Menu choices in the CDE Application Manager.

1. **Start Windows Explorer.**
2. **Copy** C: \Window\StartMenu\ **to** H: \.dt\appmanager.
3. **Start Application Manager.**
4. **Go to the desktop controls.**
5. **Click Reload Application.**

### ▼ To Log On to a Different Machine

- **Reconfigure PC launcher on the Configuration window.**

### ▼ To Reconfigure PC Launcher

- **Remove the PC's hostname in Step 2 on the PC launcher Configuration window.**

### ▼ Switch Between Targets

- **Change your selection in Step 1 on the PC launcher Configuration window.**

## Getting Help for PC Launcher

Help for PC launcher is available through the Help menu at the bottom of the PC launcher Configuration window.

---

# PC File Viewer

## PC File Viewer

The PC file viewer software provides you with an application to view popular PC file formats such as Microsoft Word, PowerPoint, Excel, Lotus 1-2-3, and AutoCAD. Use the viewer to choose a file and to copy and paste information from the viewer to another application, such as a text editor. CDE applications will be able to identify these filetypes and launch this application by double-clicking on the icon in your mail attachment or from File Manager (`dtfile`).

## File Formats Supported

PC file viewer supports 17 different file types:

### Word Processing Formats

- Microsoft Word for Windows versions through 7.0 and Word 97
- Microsoft Windows Works versions through 4.0
- Word Perfect for Windows versions through 7.0
- AMI/AMI Professional versions through 3.1

### Spreadsheet Formats

- Microsoft Excel Windows versions 2.2 through 7.0 and Excel 97
- Microsoft Excel Chart versions 2.x through 7.0
- Microsoft Windows Works versions through 4.0
- Lotus 1-2-3 Windows versions through 6.x
- Lotus 1-2-3 Chart Windows versions through 5.0
- QuattroPro for Windows versions through 7.0

### Presentation Formats

- Microsoft PowerPoint versions through 7.0 and PowerPoint 97
- Corel Presentation versions through 7.0
- Freelance versions 1.0 and 2.0

### Graphics Formats

- BMP—Windows
- DXF—versions through 13
- GEM—bitmap and vector

- PIC—Lotus

## PC File Viewer Limitations

PC file viewer is limited to the following products and configurations for this Solaris release:

- SPARC architecture ONLY
- Printing is not supported

The following limitations are related to displaying items in a supported file:

- Charts are not supported in QuattroPro.
- Text that is designed to be shown vertically is shown horizontally in the viewer. This vertical text may overlap adjacent cells making reading what is in them difficult.
- Figures and footers are aligned with the anchors in the text. If font sizes on the viewing system are not identical to those on the authoring system, then anchored objects will not be at the appropriate place in the text.
- There is limited support for incremental shading in presentation file formats
- There is no support for drawing objects in Microsoft Word and Lotus.
- Borders in Word Perfect and AmiPro files are not supported
- Copy & Paste does not work for Japanese text in Microsoft Office applications.

---

**Note** – All of the above limitations also exist in the Microsoft Windows version of the product from Inso Corporation.

---

- There is no support for OLE objects.
- If a font that is used in a document is not on the system, the default system font is used and the viewed text may look different than what was seen in the authoring application.
- If a special character is used in a document that is not in the available character set, it is replaced by an asterisk in the document as shown by the file viewer.

## Installing PC File Viewer

See “Installing Supplement CD Software” on page 18.

# Adding PC File Viewer to the CDE Front Panel

## ▼ To Add PC File Viewer to the CDE Front Panel

- 1. Open File Manager (dtfile).**
- 2. Go to the `/opt/SUNWdtpcv/bin` directory.**  
The PC file viewer icon appears there.
- 3. Open the CDE front panel where you want the icon.**  
For example, the Application or File sub-folder.
- 4. Drag and drop the PC file viewer icon from File Manager to InstallIcon in the selected subfolder.**
- 5. Launch PC file viewer by clicking on the icon in the CDE front panel.**  
You can also promote the icon to appear on the front panel by default.

---

## ShowMe TV 1.3 Software

ShowMe TV is a television system for local- and wide-area networks. You can use it to view and broadcast live or prerecorded video programs on your network. Here are some examples of how you can use ShowMe TV:

- Broadcast and view training courses
- Lectures
- Corporate messages
- Monitor important news events

ShowMe TV contains the following components:

- ShowMe TV Receiver
- ShowMe TV Transmitter
- ShowMe TV Address Book

# ShowMe TV Packages

TABLE 3-7 lists the packages that are provided with ShowMe TV.

**TABLE 3-7** ShowMe TV Packages

Package Name	Description	Default Install Location
SUNWsmtvh	Online help binaries and documentation	/opt/SUNWsmtv
SUNWsmtvr	ShowMe TV receiver application and support files	/opt/SUNWsmtv
SUNWsmtv	ShowMe TV transmitter application and support files	/opt/SUNWsmtv
SUNWsmtvu	Support utilities	/opt/SUNWsmtv

## Removing Old Packages

If you have ShowMe TV 1.1, 1.2, or 1.2.1 installed, you need to remove it before installing ShowMe TV 1.3.

- **To remove ShowMe TV 1.1, type:**

```
# pkgrm SUNWsmUt1 SUNWstv SUNWstv
```

If you have an earlier release of ShowMe TV 1.2 installed, you need to remove it before installing any new software packages.

- **To remove ShowMe TV 1.2 or 1.2.1, type:**

```
# pkgrm SUNWsmvt SUNWsmvtu SUNWsmtvr SUNWsmtvh
```

## Installing ShowMe TV

See “Installing Supplement CD Software” on page 18.



# Translated Documentation

The Supplement CD contains the *ShowMe TV User's Guide* in the following languages:

- French
- German
- Spanish
- Italian
- Swedish
- Japanese
- Korean
- Simplified Chinese
- Traditional Chinese

## ▼ To Access the ShowMe TV User's Guide

The `/cdrom/cdrom0/ShowMeTV1.3/Docs/UserGuide` directory on the Supplement CD contains the following files:

**TABLE 3-8** ShowMe TV Translated Documents

File Name	Description
UG_en.ps	English PostScript™ file
UG_de.ps	German PostScript file
UG_fr.ps	French PostScript file
UG_es.ps	Spanish PostScript file
UG_it.ps	Italian PostScript file
UG_sv.ps	Swedish PostScript file
UG_ja.ps	Japanese PostScript file
UG_ko	Korean HTML files
UG_zh	Simplified Chinese HTML files
UG_zh_TW	Traditional Chinese HTML files

- **To view the desired PostScript manual, type the following at the command line:**

```
# imagetool filename
```

- To print the manual, either use the File menu in Image Tool or type the following at the command line:

```
# lp filename
```

- To view the manuals in HTML format, use a Web browser and type the following in the address field:

```
file:/cdrom/cdrom0/ShowMeTV1.3/Docs/UserGuide/directory
```

If you have copied the HTML files to a different directory, type in the path to that directory. Open the table of contents to determine which file to open.

---

## Sun Remote System Control for Sun Servers

Sun Remote System Control (RSC) is a secure server management tool that lets you monitor and control a Sun Enterprise 250, Sun Fire 280R, or Sun Fire 880 server over modem lines and over a network, using Solaris operating environment or Microsoft Windows clients. RSC can also notify you when server problems occur. RSC provides remote system administration for geographically distributed or physically inaccessible systems. All hardware functionality required to support RSC is already included with your Sun Enterprise 250, Sun Fire 280R, or Sun Fire 880 server.

The Sun Remote System Control for Sun Servers software is provided on the Supplement CD. For installation information, see “Installing Supplement CD Software” on page 18. For configuration information for Remote System Control, see *Remote System Control (RSC) User’s Guide*.

---

## SunForum

SunForum is a data conferencing product for Sun workstations. It is based on the T.120 standard, which enables your Sun system to conference over intranets and the Internet with other T.120 products, such as Microsoft NetMeeting and PictureTel LiveShare Plus, version 4.0.

SunForum includes the following features:

- View and control applications shared from other UNIX or PC machines that are based on the T.120 protocol.
- Share local Solaris applications, which can be viewed and controlled by any conference participant.
- Exchange ideas and data using the whiteboard, clipboard, chat, and file transfers.

## Installing SunForum

See “Installing Supplement CD Software” on page 18.

## Online Help

You can read information about SunForum online. You can access help from the Help menu located on any SunForum menu bar.

---

# Network Adapter Drivers Included on the Supplement CD

The following software is provided on the Supplement CD contained in your Solaris 8 4/01 Media Kit:

- SunFDDI PCI driver software
- SunFDDI SBus driver software
- SunHSI PCI driver software
- SunHSI SBus driver software
- SunATM 5.0 software

---

**Note** – SunFDDI supports booting from the 32-bit kernel or the 64-bit kernel. SunFDDI will attach to whichever you choose to boot from with no special user interaction.

---

# Installing the Drivers

---

**Note** – Before installing driver software from the Supplement CD, make sure that you have already installed the adapter hardware. Refer to the appropriate Platform Notes for more information.

---

See “Installing Supplement CD Software” on page 18.

## Platform Notes for Network Adapter Drivers

Refer to the following platform notes for more information:

- *Platform Notes: Sun FDDI Adapters*
- *Platform Notes: The Sun GigabitEthernet Device Driver*
- *Platform Notes: The SunHSI/P Device Driver*
- *Platform Notes: The SunHSI/S Device Driver*
- *Platform Notes: SunATM Driver Software*
- *Platform Notes: The hme FastEthernet Device Driver*

---

## Java 3D 1.2 API

The Java 3D 1.2 API is a set of classes for writing three-dimensional graphics applications and 3D applets. It gives developers high level constructs for creating and manipulating 3D geometry and for constructing the structures used in rendering that geometry. Application developers can describe very large virtual worlds using these constructs, which provide Java 3D software with enough information to render these worlds efficiently.

## Installation Dependencies

- OpenGL 1.1 software or later
- JDK 1.2 software or later

## Installing Java 3D 1.2 API

See “Installing Supplement CD Software” on page 18.

---

## Sun Enterprise 10000 SSP Software

For SSP installation and update procedures, as well as SSP release notes, see the *Sun Enterprise 10000 SSP Installation and Release Notes*, a printed copy of which is included in your media kit.

---

## Sun Enterprise 10000 Capacity on Demand 1.0 Software

For Capacity on Demand software installation, as well as release notes, see the *Sun Enterprise 10000 Capacity on Demand 1.0 Installation Guide and Release Notes*, a printed copy of which is included in your server media kit.

---

## Netra ct Platform Software

The Netra ct Platform 1.0 software on the Supplement CD contains the software required to support environmental monitoring, alarms (RSC software), and SNMP monitoring of the Netra ct servers.

The two current Netra ct servers are the Netra ct800 and the Netra ct400.

The software should not be installed on servers that are not Netra systems.



# Documents on the Computer Systems Supplement CD

---

Documents on the supplement CD are divided into three formats:

- AnswerBook2 collections,
- Man pages
- Other formats

---

## AnswerBook2 Sets

For customers using Sun hardware, four sets of online manuals in AnswerBook2 format are provided on the Supplement CD.

## Installing Solaris 8 4/01 AnswerBook Sets

See “Installing Supplement CD Software” on page 18 for information about installing the Sun Computer Systems AnswerBook2 packages.

Refer to the *Solaris 8 (SPARC Platform Edition) Installation Guide* for information about installing AnswerBook sets.

Refer to the “Accessing Sun Documentation Online” module in the *Solaris 8 Installation Guide* for information about how to install document collections on an AnswerBook2 server.

# Solaris 8 4/01 AnswerBook Packages

The following table lists the packages that are provided for the Solaris 8 4/01 AnswerBook collections.

**TABLE 4-1** Solaris 8 4/01 AnswerBook Packages on the Supplement CD

AnswerBook Package Location	Description
Sun_Hardware_Answerbook/Product/SUNWabhdw	Solaris on Sun Hardware AnswerBook collection
System_Service_Processor_3.4/Product/SUNWuessp	SSP AnswerBook collection
Alternate_Pathing_2.3.1/Product/SUNWabap	Alternate Pathing AnswerBook collection
Capacity_on_Demand_1.0/Product/SUNWcodbk	Capacity on Demand AnswerBook collection

## Solaris 8 4/01 on Sun Hardware AnswerBook Set

This AnswerBook set includes general manuals as well as Platform Notes, which are manuals that cover use of Solaris 8 4/01 software with specific Sun hardware products.

This AnswerBook set includes:

Title	Contents
<i>Solaris on Sun Hardware Reference Manual Supplement</i>	Information to help you find a compilation of manual pages provided in packages on the Supplement CD. Includes man pages that cover SunVTS software.
<i>Solaris Handbook for Sun Peripherals</i>	Information about installing drives and other peripherals for use with the Solaris 8 4/01 software environment. Covers issues such as configuring SCSI addresses.
<i>Solaris Handbook for Sun Frame Buffers</i>	Information on how to use features of the TurboGXPlus, SX, PGX (m64) and Creator Graphics Accelerator frame buffers. Also explains how to configure multiple monitors on a system. (In some past Solaris releases, this manual was titled <i>Platform Notes: SMCC Frame Buffers</i> .)
<i>NFS Server Performance and Tuning Guide</i>	Information about the performance and tuning of an NFS server.
<i>SunVTS 4.3 User's Guide</i>	Basic instructions on using the SunVTS diagnostic software.



<b>Title</b>	<b>Contents</b>
<i>SunVTS 4.3 Test Reference Manual</i>	Information about each test provided with the SunVTS diagnostic software.
<i>SunVTS Quick Reference Card</i>	A quick reference card for the SunVTS diagnostic software.
<i>PCI: SBus Comparison</i>	Feature differences between SBus and PCI.
<i>Platform Notes: The hme FastEthernet Device Driver</i>	Information on how to configure the hme device driver for use with the Ultra Workstation series platform, Sun Enterprise servers, SunSwift SBus adapter, SunSwift PCI adapter, and PCI SunFastEthernet card.
<i>Platform Notes: SPARCstation 10SX and 20 System Configuration Guide</i>	Information about how to take advantage of graphics memory and acceleration features of these systems.
<i>Platform Notes: Sun Enterprise 6000, 5000, 4000, and 3000 Systems</i>	Sun Enterprise X000-specific OpenBoot™ commands, including those for board hot-plug operations. Also contains board hot-plug procedures, and miscellaneous related information.
<i>Platform Notes: Sun Enterprise 250 Server</i>	New OpenBoot commands, configuration variables, and disk drive hot-plug procedures. Also provides procedures for mapping between logical and physical device names for internal storage devices.
<i>Platform Notes: Sun Ultra 450 Workstation and Sun Enterprise 450 Server</i>	New OpenBoot commands, configuration variables, and disk drive hot-plug procedures. Also provides procedures for mapping between logical and physical device names for internal storage devices.
<i>Platform Notes: Using luxadm Software</i>	Instructions on using the luxadm administrative program with the Sun StorEdge A5000, the SPARCstorage Array, and the Sun Fire 880 internal storage array..
<i>Platform Notes: Sun FDDI Adapters</i>	Information about how to configure the SunFDDI driver software and use the SunFDDI network utilities.
<i>Platform Notes: Sun GigabitEthernet Device Driver</i>	Information on how to configure the Sun GigabitEthernet driver software.
<i>Platform Notes: The SunHSI/S Device Driver</i>	Describes how to configure the SunHSI SBus driver software.
<i>Platform Notes: The SunHSI/P Device Driver</i>	Describes how to configure the SunHSI PCI driver software.
<i>Platform Notes: The SunATM Driver Software</i>	Describes how to configure the SunATM driver software.
<i>Dynamic Reconfiguration User's Guide for Sun Enterprise 6x00, 5x00, 4x00, 3x00 Systems</i>	Information about how to use Dynamic Reconfiguration software features on these Sun Enterprise servers.
<i>Platform Notes: the Sun Quad FastEthernet Device Driver</i>	Describes how to configure the Sun Quad FastEthernet driver software.
<i>Solaris 8 4/01 Sun Hardware Platform Guide</i>	Contains information about installing software from the Supplement CD and other system products hardware issues.
<i>Platform Notes: the eri FasEthernet Device Driver</i>	Describes how to configure the eri FastEthernet driver software.

<b>Title</b>	<b>Contents</b>
<i>Sun Enterprise 10000 DR Configuration Guide</i>	Contains configuration information for Dynamic Configuration on the Sun Enterprise 10000 system.
<i>Sun Enterprise 10000 DR Error Messages</i>	Describes error messages for Dynamic Configuration on the Sun Enterprise 10000 system.
<i>Sun Enterprise 10000 IDN Error Messages</i>	Describes error messages for IDN on the Sun Enterprise 10000 system.
<i>Sun Enterprise 10000 IDN Configuration Guide</i>	Contains configuration information for IDN on the Sun Enterprise 10000 system.
<i>Sun Fire 880 Dynamic Reconfiguration User's Guide</i>	Contains information about how to use Dynamic Configuration software features on the Sun Fire 880 system.

## Sun Enterprise 10000 SSP AnswerBook Set

This AnswerBook set includes:

<b>Title</b>	<b>Contents</b>
<i>Sun Enterprise 10000 SSP 3.4 User Guide</i>	User information for Sun Enterprise 10000 System Service Processor (SSP) software
<i>Sun Enterprise 10000 SSP 3.4 Reference Manual</i>	Man pages for Sun Enterprise 10000 System Service Processor (SSP)
<i>Sun Enterprise 10000 Dynamic Reconfiguration User Guide</i>	User information for Sun Enterprise 10000 Dynamic Reconfiguration software
<i>Sun Enterprise 10000 Dynamic Reconfiguration Reference Manual</i>	Man pages for Sun Enterprise 10000 Dynamic Reconfiguration
<i>Sun Enterprise 10000 InterDomain Networks User Guide</i>	User information for Sun Enterprise 10000 InterDomain Networks (IDN) software

# Alternate Pathing AnswerBook Set

This AnswerBook set includes:

Title	Contents
<i>Sun Enterprise Server Alternate Pathing 2.3.1 User Guide</i>	User information for Alternate Pathing software
<i>Sun Enterprise Server Alternate Pathing 2.3.1 Reference Manual</i>	Man pages for Alternate Pathing software

# Capacity On Demand AnswerBook Set

This AnswerBook set includes:

Title	Contents
<i>Sun Enterprise 10000 Capacity on Demand 1.0 Administrator Guide</i>	System administrator information for Capacity on Demand on the Sun Enterprise 10000 server
<i>Sun Enterprise 10000 Capacity on Demand 1.0 Reference Manual</i>	Man pages for Capacity on Demand on the Sun Enterprise 10000 server

---

# Sun Computer Systems Manual Page Packages

Manual pages for products you install using Solaris Web Start 2 will be automatically installed. If you want to install a man page for a product but do not want to install the product, you can use `pkgadd` to install the man page.

**TABLE 4-2** Sun Computer Systems Manual Page Packages on the Supplement CD

Package	Name	Description
SUNWvtsmn	Online Validation Test Suite Manual Pages	Manual pages for SunVTS drivers/binaries
SUNWnfm	SunFDDI SBus Manual Pages	Manual pages for SunFDDI SBus
SUNWpfm	SunFDDI PCI Manual Pages	Manual pages for SunFDDI PCI
SUNWapdoc	Sun Alternate Pathing Manual Pages	Manual pages for Sun Alternate Pathing

**TABLE 4-2** Sun Computer Systems Manual Page Packages on the Supplement CD

Package	Name	Description
SUNWhsism	SunHSI/S Manual Pages	Manual pages for SunHSI SBus
SUNWhsipm	SunHSI/P Manual Pages	Manual pages for SunHSI PCI
SUNWsspnm	SSP Manual Pages	Manual pages for SSP
SUNWcodmn	Capacity on Demand Manual Pages	Manual pages for COD

## Installing Sun Computer Systems Manual Pages

See “Installing Supplement CD Software” on page 18.

## Using Sun Computer Systems Manual Pages

To view the man pages you have installed, use the `man` command as you would for the man pages installed as part of the Solaris operating environment installation. These additional man pages are also available in the *Solaris on Sun Hardware Reference Manual Supplement* in the Solaris 8 4/01 on Sun Hardware AnswerBook set.

---

## Other Documents on the Computer Systems Supplement CD

The following table lists the documents on the Computer Systems Supplement CD that are not part of AnswerBook sets and are not man pages. :

**TABLE 4-3** Other Documents on the Supplement CD

Path	Comment
Docs/README_en.html	Readme file for Solaris 8 4/01 Sun Computer Systems Supplement CD
Docs/HWPG/HWPG_en.ps	<i>Solaris 8 4/01 Sun Hardware Platform Guide</i> (also available in hardcopy AnswerBook form)
ShowMeTV_1.3/Docs/UserGuide/UG_en.ps	<i>ShowMe TV™ 1.3 User's Guide</i>
SunForum_3.1/Docs/sunforumUG.ps	<i>SunForum™ User's Guide</i>

---

**Note** – The `_en` indicates an English language document. Other languages may be indicated, depending on locale.

---



# Updating the Flash PROM on the Ultra 1, Ultra 2, Ultra 450, and Sun Enterprise 450 Systems

---

This chapter describes how to update the flash PROM on the Ultra™ 1, Ultra 2, Ultra 450, and the Sun™ Enterprise™ 450 systems.

Some systems require a higher level of OpenBoot™ firmware in the flash PROM to run the 64-bit mode of the Solaris™ 8 operating environment. The OpenBoot firmware is contained within a single flash PROM for the Ultra 1, Ultra 2, Ultra 450, and the Sun Enterprise 450 systems.

---

**Note** – Only those systems identified in this chapter and the following chapter need the flash PROM upgrade.

---

The flash PROM devices, which contain OpenBoot, are electrically erasable and writable devices. This means that the firmware can be updated without removing the flash PROM from the system board.

---

## Related Material

You can also use the Flash PROM Update Multimedia Collection containing videos of how to upgrade the flash PROM in the Ultra 1, Ultra 2, Ultra 450, and Sun Enterprise 450 systems. This collection is located on the Flash PROM Update Multimedia AnswerBook CD. For more information, see “Flash PROM Update Multimedia Collection” on page 75.

---

# Determining If the Flash PROM Needs Updating

Only sun4u systems that can run the 64-bit mode of the Solaris 8 4/01 operating environment might need the flash PROM update. Systems that can only run the 32-bit mode (such as those in the sun4c, sun4d, and sun4m platform groups) do not require updated firmware to run Solaris 8 4/01 software.

---

**Note** – If the Solaris 8 4/01 operating environment notified you that the flash PROM in your system needs updating, skip the steps in the procedure “To Determine If Your System Requires a Flash PROM Update” on page 56 and go directly to “Updating the Flash PROM” on page 57.

---

## ▼ To Determine If Your System Requires a Flash PROM Update

### 1. Determine the architecture type of your system.

```
% uname -m
```

TABLE 5-1 Determining the System Architecture

If your system architecture type is . . .	Then . . .
• sun4u	Go to Step 2.
• sun4c, sun4d, sun4m	You do not need a flash PROM update. Do not proceed further.

### 2. Determine the system type of your system.

```
% uname -i
```



**TABLE 5-2** Determining the System Type

If your system type is one of the following systems. . .	Then . . .
SUNW, Ultra-1 SUNW, Ultra-2 SUNW, Ultra-4 SUNW, Ultra-Enterprise	Go to Step 3 for each system type.
Not in the above list	You do not need a flash PROM update. Do not proceed further.

**3. Determine the version level of the firmware in your system. Type:**

```
% prtconf -v
```

**TABLE 5-3** Determining the Firmware Version Level

If your system type is . . .	And you see a number lower than . . .	Then . . .	Otherwise . . .
SUNW, Ultra-1	3.11.1	Proceed to “Updating the Flash PROM” on page 57.	You do not need a flash PROM update. Do not proceed further.
SUNW, Ultra-2	3.11.2	Proceed to “Updating the Flash PROM” on page 57.	You do not need a flash PROM update. Do not proceed further.
SUNW, Ultra-4	3.7.107	Proceed to “Updating the Flash PROM” on page 57.	You do not need a flash PROM update. Do not proceed further.
SUNW, Ultra-Enterprise	3.2.16	Proceed to “Updating the Flash PROM” on page 57.	You do not need a flash PROM update. Do not proceed further.

## Updating the Flash PROM

This section describes the following:

- Capturing configuration variable settings
- Installing the Solaris 8 4/01 operating environment
- Making the flash PROM write-enabled
- Steps to perform before updating the flash PROM

## ■ Updating the flash PROM

---

**Note** – For step-by-step instructions, follow the procedures beginning with “To Capture the Configuration Variable Settings” on page 58.

---

After installing the Solaris 8 4/01 operating environment on your hardware, set the write-protect/enable flash PROM jumper to the write-enable position (Sun Ultra 1 and Ultra 2 systems) before you attempt to update the firmware in the flash PROM. To change the write protection state of the Sun Enterprise 450 system, turn the external front panel keyswitch.

Refer to the recovery procedure covered later in this chapter if there is a power interruption during the update process.

Return the write-protect/enable jumper (Sun Ultra 1 and Ultra 2 systems) to the write-protect position after updating the firmware in the flash PROM.

When your system has been updated to the proper firmware revision, you can run the Solaris 8 4/01 software in 64-bit mode.

## Capturing Configuration Variable Settings

While the Solaris operating environment is still running, capture the NVRAM configuration variable settings *before* you install the Solaris 8 4/01 operating environment or begin the flash PROM update process. This will enable you to restore customized settings if there is a problem during the flash PROM upgrade.

### ▼ To Capture the Configuration Variable Settings

1. Using the `eeeprom` utility, capture the system’s configuration variable settings in a file. The *filename* is any file name you choose.

```
% eeeprom > filename
```

---

**Note** – If you have custom values installed in `oem-logo` or `keymap`, those values cannot be displayed or printed properly by the `eeeprom` utility because the contents contain binary information. If it is necessary to restore these values after a power loss, you should determine the original method by which these values were placed into NVRAM and use that method to restore the values.

---

2. **Print out the values captured by the `eeeprom` command. Type the following:**

```
lp filename
```

You must have a printed copy of the configuration values before you install the Solaris 8 4/01 operating environment and begin to update the flash PROM.

## ▼ To Install the Solaris 8 4/01 Operating Environment

1. **Install the Solaris 8 4/01 operating environment on your system.**

Refer to the *Installation Library* shipped in your Solaris 8 4/01 media kit. As the Solaris 8 4/01 operating environment is installed, you will be notified whether the flash PROM in your system needs updating. Installing this Solaris release will provide the software that can upgrade your system's flash PROM to the required level.

## Making the Flash PROM Write-Enabled

Before you update the OpenBoot firmware contained in the flash PROM, you must set a jumper to the write-enable position (Sun Ultra 1 and Ultra 2 systems) or set the front panel keyswitch to the proper position (Sun Enterprise 450 system and the Sun Ultra 450 workstation).

The Sun Ultra 1 and Ultra 2 systems, which do not have a front panel keyswitch, are equipped with jumpers on their motherboards that allow the flash PROM to be either write-protected or write-enabled. The default position is for the flash PROM to be write-protected. To update the flash PROM, you must change the jumper to the write-enable position.

## ▼ Sun Ultra 1 and Ultra 2 Systems: To Change the Jumper to the Write-Enable Position

1. **Shut down the system. Type the following:**

```
% su
Type your superuser password
# init 0
System shutdown messages
```

2. **Power off the system unit.**

Refer to the installation guide or service manual for your system.

**3. Remove the system access cover.**

Refer to the installation guide or service manual for your system for this procedure.

**4. Use proper grounding procedures such as wearing a wrist strap to avoid electrostatically damaging system components.**

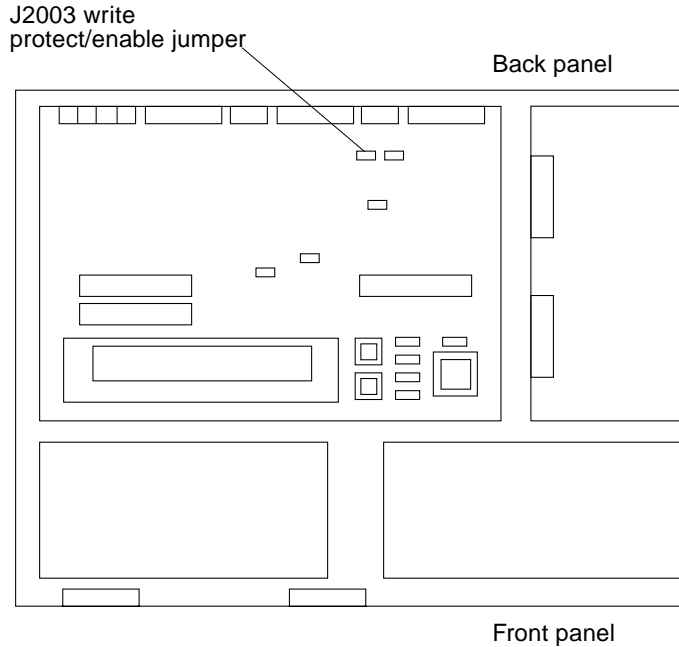
**5. Locate the flash PROM J2003 write-protect/enable jumper on the motherboard in your system:**

- See FIGURE 5-1 if you have a Sun Ultra 1 system.
- See FIGURE 5-2 if you have a Sun Ultra 2 system.

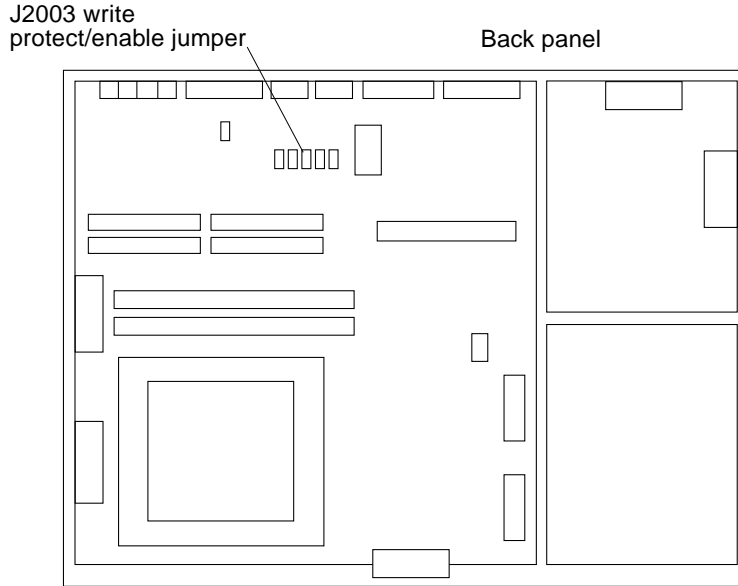
---

**Note** – You may have to remove a plug-in card if the card is covering the flash PROM jumper. Refer to the service manual for your system to remove the card.

---

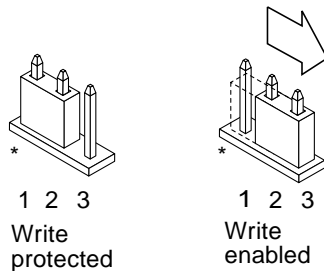


**FIGURE 5-1** Sun Ultra 1 Series Write-Protect/Enable Jumper Location on Motherboard



**FIGURE 5-2** Sun Ultra 2 System Write-Protect/Enable Jumper Location on Motherboard

- Set the J2003 write-protect/enable jumper to pins 2 and 3 (write enabled) using needlenose pliers (see FIGURE 5-3). Pin 1 is noted by an asterisk (\*).



**FIGURE 5-3** Setting the Write-Protect/Enable Jumper to the Write-Enable Position

**TABLE 5-4** Jumper Setting

Jumper	Pins 1 + 2 Jumpered	Pins 2 + 3 Jumpered	Default Jumper on Pins	Name
J2003	Write-protect	Write-enable	1 + 2	Write-protect/ enable

- If you removed a plug-in card from the system before changing the jumper, replace the card now.

8. Remove your wrist strap and replace the system access cover.
9. Go to “Before Updating the Flash PROM” on page 63.

## Sun Enterprise 450 System and the Sun Ultra 450 Workstation: Disabling Write Protection

For the Sun Enterprise 450 system and the Sun Ultra 450 workstation you do not have to change jumper pins. Instead, you move the keyswitch to allow the flash PROM to be write-enabled.

When the switch is set to the Locked position (FIGURE 5-4), the flash PROM is write-protected. When the switch is set to the On or Diagnostics position, the flash PROM is write-enabled.

### ▼ To Write Enable the Flash PROM on the Sun Enterprise 450 System and the Sun Ultra 450 Workstation

1. Turn the keyswitch to the On or Diagnostics position (FIGURE 5-4) before updating the flash PROM.

---

**Note** – Disabling write-protection the Sun Enterprise 450 system or the Ultra 450 workstation assumes that the write-protect/enable jumper was set in the default position (enabled). If you previously changed the write-protect/enable jumper to be write protected, perform the steps to make the flash PROM write enabled in “Location of Flash PROM Jumpers in Sun Enterprise 450 System and the Ultra 450 Workstation” on page 73. You must change the jumper to be write enabled before continuing with the flash PROM update procedure.

---

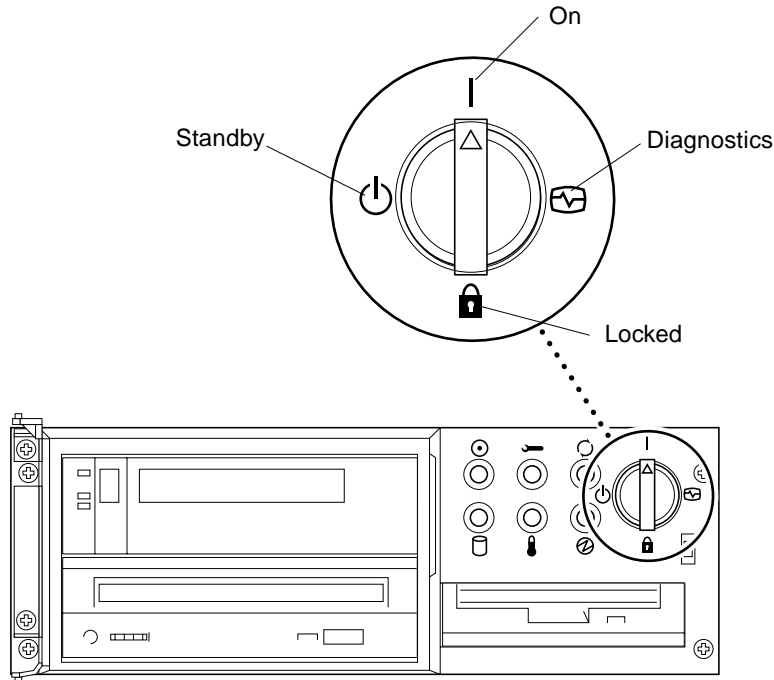


FIGURE 5-4 Sun Enterprise 450 and Sun Ultra 450 Keyswitch Location

## Before Updating the Flash PROM

Before you begin updating the flash PROM, please note the following.




---

**Caution** – Do not interrupt power during flash PROM updating. When you are using the update routine, do not remove or insert system boards.

---



---

**Note** – If power is interrupted during flash PROM updating, follow the power interruption recovery procedures covered later in this chapter.

---

### ▼ To Update the Flash PROM

1. If you shut down your system to set the write-enable jumper (Ultra 1, Ultra 2 systems), turn the system on so it can boot.

**2. Bring the system down to single user mode. Type the following:**

```
% su
Type your superuser password
# init S
```

**3. Execute the flash PROM update script by typing the following:**

```
/bin/sh /usr/platform/sun4u/lib/prom/`/usr/bin/uname -i`
```

**4. When the flash update process begins, it displays the current, available OpenBoot firmware revisions.**

Type yes to the question about updating the firmware in the system flash PROM.

---

**Note** – If the NVRAM configuration variable `use-nvramrc?` is set to true, the update script resets `use-nvramrc?` to false. You will only see the message about the `use-nvramrc?` variable if `use-nvramrc?` is set to true. This is rarely the case.

---

```
Current System Flash PROM Revision:
-----
OBP 3.5.2 1997/01/06 17:40

Available System Flash PROM Revision:
-----
OBP 3.11.1 1997/12/03 15:44

NOTE: The system will be rebooted (reset) after the firmware has
been updated.

Do you wish to update the firmware in the system Flash PROM? yes/
no :yes

The NVRAM variable 'use-nvramrc?' was 'true'. This program will
reset it to the default value 'false'. This is being done because
the contents of the NVRAM variable 'nvramrc' may or may not be
appropriate for use with the new firmware. Do not change the value
of 'use-nvramrc?' until you evaluate the contents of 'nvramrc'.
```



**5. Next, the update script asks you if you want to continue. Type yes.**

```
Are you sure that you wish to continue? yes/no :yes
```

```
**IMPORTANT** If the power fails during the firmware update that is about to take place, it is possible that the customized values in the NVRAM configuration variables will revert back to their *default values* once the system power is restored. *If* this event occurs then it could have a significant effect on the behavior of the system after power is restored. Following is a list of the system's NVRAM configuration variables which have default values and have been customized. You may wish to write this information down so that the values may be restored after recovery from a power loss.
```

```
Name: sbus-probe-list
```

```
Default: 01
```

```
Current: 10
```

```
Name: nvramrc
```

```
Default: <null>
```

```
Current: ." This is a sample message which indicates that nvramrc has been modified." cr
```

If any of the NVRAM configuration variables have been customized, the update displays both the default value and the current value.

---

**Note** – After the update, you may want to evaluate if the customized values displayed on the previous screen need to be modified.

---

The script automatically boots the machine and displays the following message:

```
Erasing the top half of the Flash PROM.
Programming OBP into the top half of the Flash PROM.
Verifying OBP in the top half of the Flash PROM.

Erasing the bottom half of the Flash PROM.
Programming OBP into the bottom half of Flash PROM.
Verifying OBP in the bottom half of the Flash PROM.

Erasing the top half of the Flash PROM.
Programming POST into the top half of Flash PROM.
Verifying POST in the top half of the Flash PROM.

The system's Flash PROM firmware has been updated.

Please wait while the system is rebooted . . .
The system's reboot messages are displayed.
.....
NOTICE: 64-bit OS installed, but the 32-bit OS is the default for
the processor on this system.

See boot(1M) for more information.
Booting the 32-bit OS/
```

**6. Become root and change the default kernel from 32-bit to 64-bit by editing the /platform/platform-name/boot.conf file.**

```
# cd /platform/sun4u/
# ls
boot.conf  cprboot    cprbooter  kadb        kernel      ufsboot
# vi boot.conf
```

Uncomment the line `ALLOW_64BIT_KERNEL_ON_UltraSPARC_1_CPU=true`.

**7. If you have a Sun Ultra 1 or Ultra 2 system, change the jumper back to the write-protect position.**

**a. Allow the system to boot so you can become superuser.**

**b. Halt the system by typing `init 0` at the superuser prompt.**

- c. Power off the system.
- d. Open the system unit (refer to the installation or service manual for your system).
- e. Attach a wrist strap properly (refer to the installation or service manual for your system).
- f. Reset the J2003 write-enable/protect jumper to the write-protect position. In the write-protect position pins 1 and 2 are jumpered (see FIGURE 5-1, FIGURE 5-2, FIGURE 5-5, and TABLE 5-4). You may need to remove a plug-in card from the system before resetting the jumper if the card is covering the jumper. Pin 1 is noted by an asterisk (\*).

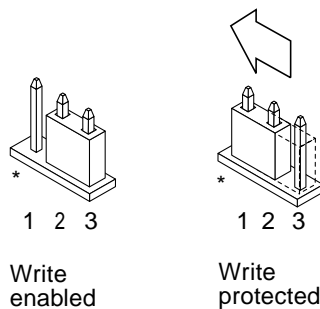


FIGURE 5-5 Moving the Write-Protect/Enable Jumper Back to the Write-Protect Position

- g. If you removed a plug-in card from the system before changing the jumper, replace the card now.
  - h. Remove your wrist strap and replace the system access cover.
  - i. Turn the power on to the system.
8. If you have a Sun Enterprise 450 system or a Sun Ultra 450 workstation, turn the keyswitch to the Standby position, wait a few seconds, and then power on again. This power-cycling flushes any old firmware code out of system memory.

---

## Recovering From a Power Failure During the Flash PROM Update

If the power was lost during the flash PROM update, complete the power interruption recovery procedure for your system.

# Sun Ultra 1 and Ultra 2 Systems, Sun Enterprise 450 System, Sun Ultra 450 Workstation

If power to your system was interrupted during updating of the flash PROM, complete the following steps:

1. **Turn the power switch to the Standby position to prevent power surge to the system when power is restored.**
2. **After power is restored to the system location, return the power switch to the On position.**

After power is restored, one of the following two recovery scenarios should happen on your system. Follow the instructions described for the appropriate scenario.

## Scenario 1—System Recovers After Power Restoration

If your system attempts to autoboot after power is restored, you *must* complete the flash PROM updating process.

## Scenario 2—System Does Not Recover After Power Restoration

If your system does not boot, run diagnostics, or return to the PROM monitor's `ok` prompt after power is restored, complete the following steps:

1. **If the update was being run via a serial port and the system also has a frame buffer and keyboard installed, or if the system has a keyboard and more than one frame buffer installed:**
  - a. **Connect a monitor to each frame buffer.**
  - b. **Confirm that output has been redirected to one of the frame buffers.**
    - The NVRAM configuration variables *might* have been modified because of the firmware update just before power was lost. If this happened, then the system output was possibly redirected to a device other than the one originally used to display it. This could only have happened if a keyboard was connected to the system.
    - If there is no keyboard connected to the system and the NVRAM configuration variables are set to their default values, then system input and output are directed to serial port A.

2. If output cannot be found on any of the installed frame buffers or serial port A, set the boot control jumper to boot from the half of the PROM that is not currently selected. See FIGURE 5-1 on page 60, FIGURE 5-2, FIGURE 5-6, and FIGURE 5-7. An asterisk (\*) on the main logic board notes the location of pin 1.

- If the jumper is set for high-half booting, move it to low-half booting (pins 2 and 3 jumpered). See FIGURE 5-6.
- If the jumper is set for low-half booting, move it to high-half booting (pins 1 and 2 jumpered). See FIGURE 5-6.

TABLE 5-5 Boot Control Jumper

System	Jumper	Pins 1 + 2 Jumpered	Pins 2 + 3 Jumpered	Default Jumper on Pins	Name
Ultra 1, 2	J2204	High-half booting	Low-half booting	2 + 3	Boot control
Sun Enterprise 450 or Sun Ultra 450 workstation	J5501	High-half booting	Low-half booting	2 + 3	Boot control

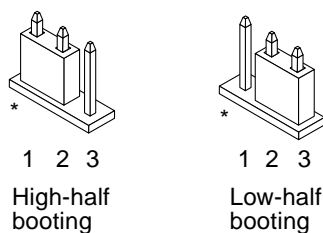


FIGURE 5-6 Setting the Boot Control Jumper to Low-Half Booting or High-Half Booting

3. Power on the system unit.

- If the system recovers, complete the programming process by rebooting.
- If the system does not recover, repeat Step 1 and Step 2 a second time.

4. If the system *still* does not recover, contact your Sun service provider or local Sun service Authorized Service Provider.

---

# Restoring NVRAM Configuration Variables

If for any reason, the flash PROM update process did not complete successfully, for example if you lost power, you may have to restore `diag-switch?` to its default value of false and restore any customized values to the other NVRAM configuration variables.

---

**Note** – Use the steps in this section only if for any reason your NVRAM configuration variables were not reset to their customized values or if `diag-switch?` was not set to its proper value.

---

## 1. Reboot the system by typing `reboot` at the prompt.

If `diag-switch?` was set to true and the system is power cycled, diagnostics will be run. Running diagnostics could take several minutes. Also, the system will attempt to boot from the network once the diagnostics have completed running.

---

**Note** – Other NVRAM variables may be reset to their default values, which could affect the system in other ways. For example, if you ran the flash PROM update through the serial port and the system still has its keyboard plugged in, you will no longer get any response from the serial port connection. The firmware will be waiting for input from the keyboard.

---

## 2. As the system boots, go to the `ok` prompt by one of the following methods.

- a. Press Stop-a from the keyboard.
- b. If you are running on a terminal and connected to serial port A of the system, press the Break key.
- c. If you are connected to serial port A via telnet connection send a Break sequence by pressing the Control and ] keys simultaneously. This returns you to the telnet command line. Type `send brk` at the telnet command line.
- d. If you are connected to serial port A via a tip connection, send a Break sequence by typing the characters `~#` in quick succession.

3. **Reset the configuration variables default value to the current value (see the values you captured with the `eeeprom` command in “To Capture the Configuration Variable Settings” on page 58 and the values you wrote down earlier in this procedure in Step 1). At the `ok` prompt, type the following for *each* configuration variable:**

```
ok setenv variablename currentvalue
```

For example:

```
ok setenv auto-boot? false
```

The `setenv` command resets each configuration variable you entered to the current value.

4. **If the OpenBoot `diag-switch?` variable was set to `true` (`false` is the default) and the system is power cycled, diagnostics will run. Also, when you boot the system, the system will attempt to boot from the network. Unless you had `diag-switch?` set to `true` before the flash PROM update, set `diag-switch?` to `false`, the default value:**

```
ok setenv diag-switch? false
```

5. **If the `use-nvramrc?` configuration variable was set to `true` before the flash PROM update, as part of the update the `use-nvramrc?` variable was set to `false` because the contents of the NVRAM configuration variable `nvramrc` may or may not be appropriate for use with the new firmware. If you want to change the `use-nvramrc?` variable back to `true`, evaluate the contents of `nvramrc` first with `printenv nvramrc` then change the `use-nvramrc?` configuration variable back to `true` with the `setenv use-nvramrc? true` command.**
6. **Make sure that other configuration variables are set properly.**
  - a. Use the `printenv` OpenBoot command to display the NVRAM configuration variables and their settings.
  - b. At the PROM monitor's `ok` prompt, you can use OpenBoot commands to restore the values of the configuration variables. Refer to the *OpenBoot 3.x Command Reference Manual*. You can also use the `eeeprom` utility as superuser in the Solaris operating environment. See the `eeeprom` man page description for more information.

7. If you have a Sun Enterprise 450 or an Ultra 450, turn the keyswitch to the Standby position, wait a few seconds, and then power on again. If you have an Ultra 1 or Ultra 2 system, type `reset-all`.

If you set the `auto-boot?` NVRAM configuration variable to `true`, and the `boot-device` variable contains the device or device alias where the Solaris 8 4/01 operating environment was installed, then the system will boot the Solaris 8 4/01 operating environment.

---

## Error Messages

Most of the error messages were documented within the flash PROM update procedure. This section contains error messages that were not part of the flash PROM update procedure.

### Retained Page/mmap Failure

If you see an error message similar to the following, just after the flash update program logs on `Flash Update 2.0: Program and system initialization in progress... eeprom:(attach) No retained page found in device tree` then the update will fail with the following message if the Flash PROM Update is attempted:

```
Do you wish to update the firmware in the system Flash PROM? yes/  
no : yes  
eeprom:(mmap) on retained page failed: no retained page found  
Flash Update: MMAP call failed.  
: No such device or address
```

If this error occurs, issue a `reboot` command at the superuser prompt and allow the system to return to the Flash PROM Update inquiry WITHOUT INTERRUPTION. Attempt the flash PROM Update once again by completing the steps in the section “To Update the Flash PROM” on page 63. If the reboot was uninterrupted and the flash PROM Update fails a second time for the same reason, contact your Authorized Service Provider.

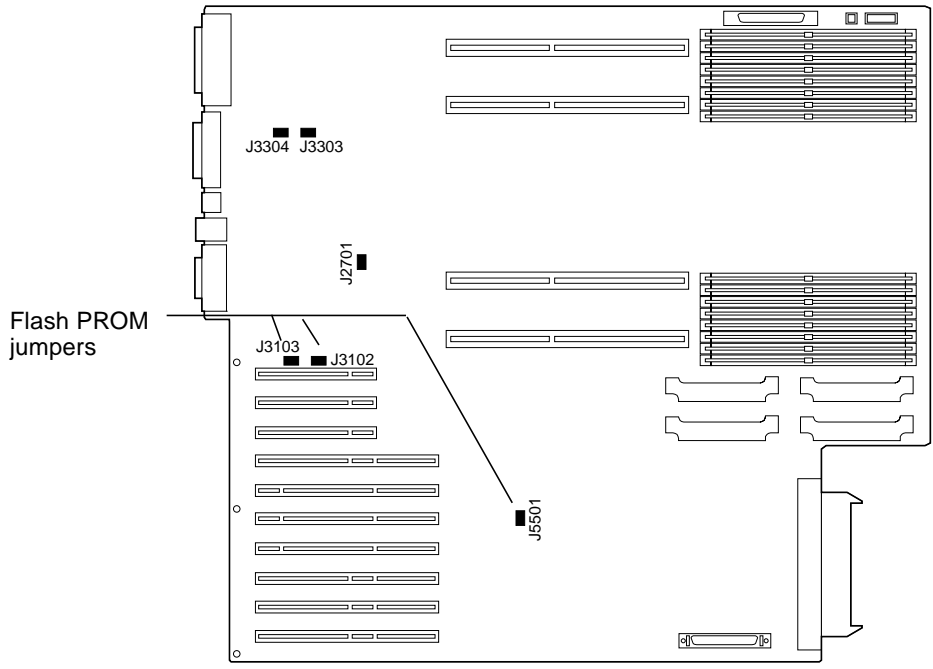


---

# Location of Flash PROM Jumpers in Sun Enterprise 450 System and the Ultra 450 Workstation

The flash PROM update procedure for the Sun Enterprise 450 and the Ultra 450 systems assumes that the write-protect/enable jumper was set in the default position (enabled). In order to update the flash PROM, you must move the write-protect/enable jumper to the write-enable position.

Three jumpers on the main logic board affect flash PROM operation. FIGURE 5-7 shows the jumper locations, and TABLE 5-6 describes their functions.

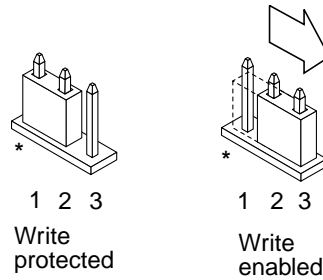


**FIGURE 5-7** Flash PROM Jumpers on the Sun Enterprise 450 System and the Sun Ultra 450 Workstation

**TABLE 5-6** Sun Enterprise 450 and Ultra 450 Flash PROM Jumper Settings

Jumper	Pins 1 + 2 Jumpered	Pins 2 + 3 Jumpered	Default on Pins	Signal Controlled
J3102	Flash PROM	Not to be used	1 + 2	FLASH PROM SEL
J3103	Write-protect	Write-enable	2 + 3	FLASH PROM PROG ENABLE
J5501	High-half booting	Low-half booting	2 + 3	XOR LOGIC SET

Make sure that the write-protect/write-enable jumper is set to the write-enable position, pins 2 and 3 jumpered (see FIGURE 5-8). Pin 1 is noted by an asterisk (\*).



**FIGURE 5-8** Setting the J3103 Write Protect/Enable Jumper on the Sun Enterprise 450 or Ultra 450

---

## Flash PROM Update Multimedia Collection

The video content of the AnswerBook2 collection is very large. You may want to view it directly from the CD rather than installing this software package on a system already running an AnswerBook2 server. You also can view the video clips directly without using AnswerBook software or a browser.

### ▼ Running the Video Clips from the CD

To run the video clips contained in this AnswerBook collection directly from the CD, perform the following steps:

1. **Insert the Flash PROM Update Multimedia AnswerBook CD into your CD-ROM drive.**
2. **Change directory to, or bring up file manager, and go to the top level of the CD-ROM volume. This should look similar to:**

```
% cd /cdrom/flash_answerbook
```

where *cdrom* is the mount-point for the CD-ROM device and *flash\_answerbook* is the name of the CD-ROM volume.

3. To run the viewing script, type:

```
% ./watch-videos
```

4. Select the first video clip you want to see.
5. Before you view another video clip, dismiss the viewer that displayed the previous video clip.

## ▼ Running an AnswerBook2 Server from the CD

To run the AnswerBook2 server directly from the CD, perform the following steps:

1. Insert the Flash PROM Update Multimedia AnswerBook CD into your CD-ROM drive.
2. Open a command window and become superuser using the `su` command and superuser password.
3. Change directory to the top level of the CD-ROM volume.

This should look similar to:

```
# cd /cdrom/flash_answerbook
```

where *cdrom* is the mount-point for the CD-ROM device and *flash\_answerbook* is the name of the CD-ROM volume.

Among other things, this directory contains the executable script `ab2cd`.

4. Run the following command:

```
# ./ab2cd
```

5. If you have existing AnswerBook2 documentation collections installed on your server machine and you want the CD-driven server software to recognize those collections, use the following command:

```
# ./ab2cd -s
```

This causes the CD-driver server software to scan for other collections installed on this system and add them to its database.

**6. You can now access the document server using the following URL:**

`http://server:8888/`

Where *server* is the name of the machine to which the CD is attached.

**7. To view video clips that are contained in an AnswerBook document, edit your browser's preferences to specify an MPEG Video application.**

For example, to make use of the ShowMe™ TV™ software provided on this CD in a Netscape Communicator browser, perform these steps:

**a. In the top bar menu of the browser, select Edit --> Preferences.**

**b. In the Preferences window, select the category Navigator and the subcategory Applications.**

**c. In the list of Applications, specify that MPEG Video is handled by the following: `showmetv -nowrap %s`.**

**d. Click OK to apply this change to the Preferences.**

**8. In the document, click the video clip icon to launch the viewer.**

**9. Before you view another video clip, dismiss the viewer that displayed the previous video clip.**

**10. To stop running the AnswerBook server from the CD, run the following command:**

```
# /cdrom/flash_answerbook/ab2cd stop
```

## Notes on Running AnswerBook2 from a CD

The following paragraphs provide important information about running the AnswerBook2 server from the CD.

### Default AnswerBook2 Port

The AnswerBook2 server run from the CD always runs on port 8888. If you already have an AnswerBook2 server running on your system using the default port (8888), the `ab2cd` script will display the following message:

```
A document server is already running on this system as server:8888.
```

Shut down the current server before running the `ab2cd` command. Use the following command to shut down the existing server:

```
# /usr/lib/ab2/bin/ab2admin -o stop
```

## Stopping the AnswerBook2 Server Process

Always use `ab2cd stop` to stop the server running from the CD. Do not use `/etc/init.d/ab2mgr stop` to stop the CD-based server.

The `ab2cd stop` command stops the AnswerBook2 server process and cleans up all files in the `/tmp/.ab2/` and `/tmp/ab2cd_config/` directories. The `/etc/init.d/ab2mgr stop` command stops all server processes, but does not clean up the files in the `/tmp/.ab2/` and `/tmp/ab2cd_config/` directories.

## Running Two AnswerBooks

To run two AnswerBook2 servers (one on your system, one from the CD), keep these rules in mind:

### *Startup*

- The `/etc/init.d/ab2mgr start` command always starts the server on your system.
- The `ab2cd` command always starts the server from the CD.

### *Shutdown*

- Always use the `ab2cd stop` command to stop the server running from the CD.
- To stop both servers, first use the `ab2cd stop` command to stop the server running from the CD, then use either `/etc/init.d/ab2mgr stop` or `/usr/lib/ab2/bin/ab2admin -o stop` to stop the server running on your system.

# Updating the Flash PROM on the Sun Enterprise 3x00, 4x00, 5x00, and 6x00 Systems

---

The steps in this chapter describe how to update the flash PROMs in your Sun Enterprise 3x00, 4x00, 5x00, or 6x00 system.

Some systems require higher level of OpenBoot™ firmware in the flash PROM to run the 64-bit mode of the Solaris™ 8 operating environment. The OpenBoot firmware is contained in several PROMs that are located on several different boards.

The flash PROM devices, which contain OpenBoot, are electrically erasable and writable devices. This means that the firmware can be updated without removing the flash PROM from the system board. This Solaris 8 4/01 kit includes the routines and instructions you need to update the flash PROM in your system.

---

## Determining If the Flash PROM Needs Updating

---

**Note** – If your system is an Ultra™ Enterprise™ 10000, you do not need to do this update because the Ultra Enterprise 10000 does not have a flash PROM.

---

Only sun4u systems that can run the 64-bit mode of the Solaris 8 4/01 operating environment might need the flash PROM update. Systems that can only run the 32-bit mode (such as those in the sun4c, sun4d, and sun4m platform groups) do not require updated firmware to run Solaris 8 4/01 software.

---

**Note** – If the Solaris 8 4/01 operating environment notified you that the flash PROM in your system needs updating, skip the steps in the procedure “To Determine If Your System Requires a Flash PROM Update” on page 80 and go directly to “Updating the Flash PROM” on page 81.

---

## ▼ To Determine If Your System Requires a Flash PROM Update

### 1. Determine the architecture type of your system.

```
% uname -m
```

**TABLE 6-1** Determining the System Architecture

If your system architecture type is . . .	Then . . .
• sun4u	Go to Step 2.
• sun4c, sun4d, sun4m	You do not need a flash PROM update. Do not proceed further.

### 2. Determine the system type of your system.

```
% uname -i
```

**TABLE 6-2** Determining the System Type

If your system type is one of the following systems. . .	Then . . .
SUNW, Ultra-1 SUNW, Ultra-2 SUNW, Ultra-4	Go to Chapter 5 “Updating the Flash PROM on the Ultra 1, Ultra 2, Ultra 450, and Sun Enterprise 450 Systems”
SUNW, Ultra-Enterprise	Go to Step 3.
Not in the above list	You do not need a flash PROM update. Do not proceed further.



3. Determine the version level of the firmware in your system. Type `prtconf -V` (upper case V).

```
% prtconf -V
```

TABLE 6-3

If your system type is . . .	And you see a number lower than . . .	Then . . .	Otherwise . . .
SUNW, Ultra-Enterprise	3.2.24	Proceed to “Updating the Flash PROM” on page 81.	You do not need a flash PROM update. Do not proceed further.
SUNW, Ultra-1	3.11.1	Proceed to Chapter 5.	You do not need a flash PROM update. Do not proceed further.
SUNW, Ultra-2	3.11.2	Proceed to Chapter 5.	You do not need a flash PROM update. Do not proceed further.
SUNW, Ultra-4	3.7.107	Proceed to Chapter 5.	You do not need a flash PROM update. Do not proceed further.

## Updating the Flash PROM

This section describes the following:

- Flash PROM update process
- Capturing NVRAM configuration variable settings
- Making the flash PROM write-enabled
- Steps to perform before updating the flash PROM
- Updating the flash PROM

### Flash PROM Update Process

---

**Note** – For step-by-step instructions, follow the procedures beginning with “Capturing Configuration Variable Settings” on page 82.

---

After installing the Solaris 8 4/01 operating environment, make sure that the external front panel keyswitch is set to the On or Diagnostics position.

Take note of screen messages, during the flash PROM update, that report configuration variables that may be reset to their default values. When the update is complete and after you either reset the system or power cycle the system, revise the configuration variables as needed to restore your preferences.

Refer to the recovery procedure covered later in this chapter if there is a power interruption during the update process.

When your system has been updated to the proper firmware revision, you can run Solaris 8 4/01 software in 64-bit mode.

## Capturing Configuration Variable Settings

While the Solaris operating environment is still running, capture the NVRAM configuration variable settings *before* you install the Solaris 8 4/01 operating environment or begin the flash PROM update process.

As part of the flash PROM update, your NVRAM configuration variables might change to the default values. To ensure that you can change the default values back to the values you customized, you need to save the current state of the NVRAM configuration variables using the `eeeprom` command.

### ▼ To Capture the Configuration Variable Settings

1. Using the `eeeprom` utility, capture the system's configuration variable settings in a file. Type `eeeprom > filename`. The *filename* is any file name you choose.

```
% eeeprom > filename
```

---

**Note** – If you have custom values installed in `oem-logo` or `keymap`, those values cannot be displayed or printed properly by the `eeeprom` utility because the contents contain binary information. If it is necessary to restore these values after a power loss, you should determine the original method by which these values were placed into NVRAM and use that method to restore the values.

---

2. Print out the values captured by the `eeeprom` command. You must have a printed copy of the configuration values before you install the Solaris 8 4/01 operating environment and begin to update the flash PROM. Type the following:

```
lp filename
```

## ▼ To Install the Solaris 8 4/01 Operating Environment

1. Install the Solaris 8 4/01 operating environment on your system.

Refer to the *Installation Library* which is in your Solaris 8 4/01 media kit. As the Solaris 8 4/01 operating environment is installed, you will be notified whether the flash PROM in your system needs updating. Installing this Solaris release will provide the software that can upgrade your system's flash PROM to the required level.

## Making the Flash PROM Write-Enabled

Before you update the OpenBoot firmware, which is contained in the flash PROM, you must set the front panel keyswitch to the proper position to allow the flash PROM to be write-enabled.

When the switch is set to the Locked position (FIGURE 6-1), the flash PROM is write-protected. When the switch is set to the On position or to the Diagnostics position, the flash PROM is write-enabled.

FIGURE 6-1 shows the keyswitch positions on a 16-slot Sun Enterprise 6000 system. The server systems described in this section have the same keyswitch positions.

## ▼ To Write Enable the Flash PROM

1. Turn the keyswitch to the On or Diagnostics position (FIGURE 6-1) before updating the flash PROM.

---

**Note** – Disabling write-protection on servers assumes that the system's write-protect/enable jumpers were set in the default position (enabled). If you previously removed the write-protect/enable jumper, perform the steps to make the flash PROM write enabled in "Location of Flash PROM Jumpers in Sun Enterprise Server Systems" on page 93.

---

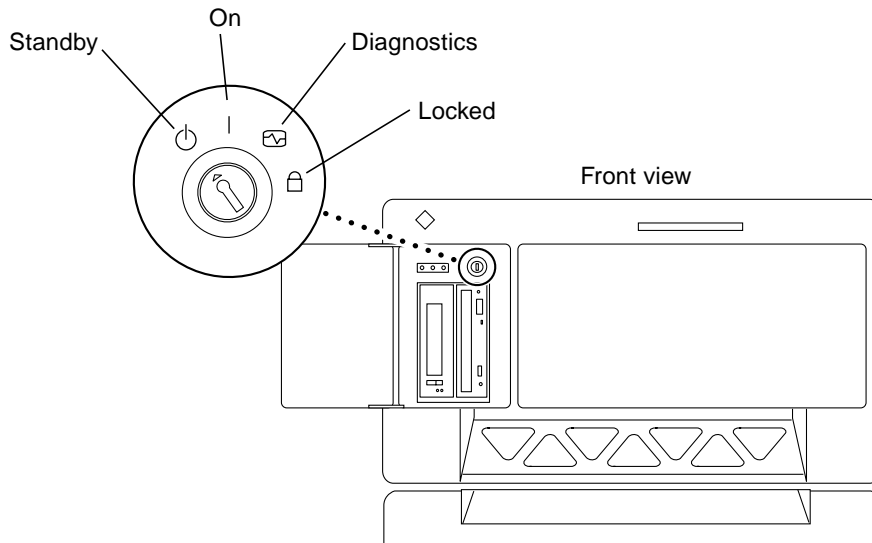


FIGURE 6-1 Sun Enterprise 6x00, 5x00, 4x00, 3x00 Keyswitch Locations

## Before Updating the Flash PROM

Before you begin updating the flash PROM, please note the following cautions.




---

**Caution** – Do not interrupt power during flash PROM updating. When you are using the update routine, do not remove or insert system boards.

---




---

**Caution** – The flash update may cause default NVRAM values to overwrite customized NVRAM variables. Be sure to record the custom and default values displayed so that you can restore them after you perform the flash PROM update.

---



---

**Note** – If power is interrupted during flash PROM updating, follow the power interruption recovery procedures covered later in this chapter.

---

## Running the Flash PROM Update Script Manually

The flash PROM update script is typically run at bootup. You can also run the flash PROM update script manually by doing the following:

1. **Bring the system down to single user mode. Type the following:**

```
% su
Type your superuser password
# init s
```

2. **Execute the flash PROM update script by typing the following:**

```
/bin/sh /usr/platform/sun4u/lib/prom/`/usr/bin/uname -i`
```

Follow the step-by-step instructions when running the script in the section “To Update the Flash PROM”. Begin with Step 2 (do not execute the `reboot` command).

### ▼ To Update the Flash PROM

1. **Reboot your system. Type `reboot` at the superuser prompt.**

```
# reboot
```

**2. If your flash PROM needs to be updated, the flash PROM update script displays the following message:**

```
This system has older firmware.  Although the current firmware is
fully capable of running the 32-bit packages, you will not be able
to run the 64-bit packages installed on this system until you
update the system flash PROM.
```

```
This system ships with flash PROM write-protect jumpers in the
"write enabled" position.  Unless the jumpers on this system have
been changed, there is no need to change them in order to run the
system flash PROM update.
```

```
The front panel keyswitch on this system must NOT be in the
"SECURE" position while the system flash PROM update is running.
Please check the keyswitch position before answering the next
question.
```

```
See the Hardware Platform Guide for more information.
```

```
Please answer the next question within 90 seconds, or press the
ENTER key to disable the timer.
```

```
Would you like to run the system flash PROM update now?
(By default the system flash PROM update will not be run now.)
yes or no? [y,n] y
Extracting files
Loading flashprom driver
```

**3. When the flash update process begins, it displays the current and available system board PROM revisions.**

```
Current System Board PROM Revisions:
```

```
-----
```

```
Board 0: CPU/Memory OBP 3.2.16 1998/06/08 16:58 POST 3.9.4 1998/06/09 16:25  
Board 2: CPU/Memory OBP 3.2.16 1998/06/08 16:58 POST 3.9.4 1998/06/09 16:25  
Board 4: CPU/Memory OBP 3.2.16 1998/06/08 16:58 POST 3.9.4 1998/06/09 16:25  
Board 6: CPU/Memory OBP 3.2.16 1998/06/08 16:58 POST 3.9.4 1998/06/09 16:25  
Board 1: I/O Type 2 FCODE 1.8.3 1997/11/14 12:41 iPOST 3.4.6 1998/04/16 14:22  
Board 3: I/O Type 5 FCODE 1.8.7 1997/12/08 15:39 iPOST 3.4.6 1998/04/16 14:22  
Board 7: I/O Type 5 FCODE 1.8.7 1997/12/08 15:39 iPOST 3.4.6 1998/04/16 14:22
```

```
Available 'Update' Revisions:
```

```
-----
```

```
CPU/Memory OBP 3.2.16 1998/06/08 16:58 POST 3.9.4 1998/06/09 16:25  
I/O Type 1 FCODE 1.8.3 1997/11/14 12:41 iPOST 3.4.6 1998/04/16 14:22  
I/O Type 2 FCODE 1.8.3 1997/11/14 12:41 iPOST 3.4.6 1998/04/16 14:22  
I/O Type 3 FCODE 1.8.7 1997/05/09 11:18 iPOST 3.0.2 1997/05/01 10:56  
I/O Type 4 FCODE 1.8.7 1997/12/08 15:39 iPOST 3.4.6 1998/04/16 14:22  
I/O Type 5 FCODE 1.8.7 1997/12/08 15:39 iPOST 3.4.6 1998/04/16 14:22
```

**4. If any of the NVRAM configuration variables have been customized, the update displays both the default value and the customized (current) value.**

```
Verifying Checksums: Okay

Do you wish to flash update your firmware? y/[n] : y
**IMPORTANT** As a consequence of the firmware upgrade that is
about to take place, it is very possible that the customized values
in the configuration variables will revert to their *default
values* upon the next system power-cycle or soft-reset. If this
happens, it could have a significant effect on the behavior of the
system after the power-cycle or soft-reset.
Following is a list of the system's NVRAM configuration variables
which have been customized (i.e. they are different than the
default values).
You may wish to write down the values of the indicated
configuration variables so that they may be restored (if necessary)
after the next power-cycle or soft-reset.
Name: auto-boot?
Default: true
Current: false

Name: boot-file
Default: <null>
Current: kadb -d
```

**5. Take note of the variables and values for current settings.**

Either write down the current values or mark up the eeprom output you captured in “To Capture the Configuration Variable Settings” on page 82 so that you know which NVRAM configuration variables will need to be changed from their default values after the flash PROM update.

**6. If the keyswitch is set to the locked position, you will see the following error message..**

```
FPROM Write Protected: Check Write Enable Jumper or Front Panel
Key Switch.
```

Make the flash PROM write-enabled by turning the keyswitch to the On or Diagnostics position then type `reboot` at the `#` prompt



7. The update then prompts you if you want to continue. Make sure that you have turned the keyswitch to the On or Diagnostics position then type y. The flash PROMs are updated.

```
Are you sure that you wish to continue? y/[n] : y

Updating Board 0: Type 'cpu' (PromID=1a4)
1 Erasing ..... Done.
1 Verifying Erase ..... Done.
1 Programming ..... Done.
1 Verifying Program ..... Done.

Updating Board 1: Type 'upa-sbus' (PromID=1a4)
1 Erasing ..... Done.
1 Verifying Erase ..... Done.
1 Programming ..... Done.
1 Verifying Program ..... Done.

Updating Board 4: Type 'dual-pci' (PromID=1a4)
1 Erasing ..... Done.
1 Verifying Erase ..... Done.
1 Programming ..... Done.
1 Verifying Program ..... Done.

Updating Board 6: Type 'dual-pci' (PromID=1a4)
1 Erasing ..... Done.
1 Verifying Erase ..... Done.
1 Programming ..... Done.
1 Verifying Program ..... Done.

Unloading flashprom driver

The new firmware will not take effect until the system is power-
cycled.
```

8. After the flash PROMs are updated, the system asks if you would like to halt the system. Type yes.

```
Do you wish to halt the system now? yes or no? yes

The system's shutdown messages are displayed.

Program terminated
ok
```

---

**Note** – If you answered no to the question on halting the system, the installation will continue but the updated firmware will not become effective until the next system reboot. The NVRAM configuration variables are changed to default values at the next system reboot. If you customized NVRAM configuration variables you must change the values back to their customized settings.

---

9. Turn the keyswitch to the Standby position.
10. Turn the power on to the system. As the system boots, diagnostics will be run at boot up because the OpenBoot `diag-switch?` was set to `true` in the flash PROM update procedure. Running diagnostics could take several minutes.

---

**Note** – Other NVRAM variables may be reset to their default values, which could affect the system in other ways. For example, if you ran the flash PROM update through the serial port and the system still has its keyboard plugged in, you will no longer get any response from the serial port connection. The firmware will be waiting for input from the keyboard. TABLE 6-4, which follows, describes the workarounds for NVRAM settings.

---

11. As the system boots, go to the `ok` prompt by one of the following methods.
  - a. Press Stop-a from the keyboard.
  - b. If you are running on a terminal and connected to serial port A of the system, press the Break key.
  - c. If you are connected to serial port A via telnet connection send a Break sequence by pressing the Control and ] keys simultaneously. This returns you to the telnet command line. Type `send brk` at the telnet command line.
  - d. If you are connected to serial port A via a tip connection, send a Break sequence by typing the characters `~#` in quick succession.

12. **Reset the configuration variables default value to the current value (see the values you captured with the `eeeprom` command in “To Capture the Configuration Variable Settings” on page 82 and the values you wrote down earlier in this procedure in Step 1). At the `ok` prompt, type the following for *each* configuration variable:**

```
ok setenv variablename currentvalue
```

For example:

```
ok setenv auto-boot? false
```

The `setenv` command resets each configuration variable you entered to the current value.

13. **When you updated the flash PROM, the OpenBoot `diag-switch?` variable was also set to `true`. With `diag-switch?` set to `true`, diagnostics will run when you reboot the system. If you don't want diagnostics to be run at boot up, set `diag-switch?` to `false` with the `setenv diag-switch? false` command.**
14. **Make sure that other configuration variables are set properly. TABLE 6-4 describes what might occur if you did not have the default NVRAM configuration variables set before the flash PROM update.**
  - a. Use the `printenv OpenBoot` command to display the NVRAM configuration variables and their settings.
  - b. Use the `setenv OpenBoot` command to restore the NVRAM configuration variables to the customized values except for the `nvrामrc` configuration variable.

- c. For the `nvrामrc` configuration variable refer to TABLE 6-4 for how to restore the configuration variable to the customized settings. For additional information on the NVRAM configuration variables, refer to the *OpenBoot 3.x Command Reference Manual*.

TABLE 6-4

Variable Name	Default Value	Description
<code>output-device</code>	<code>screen</code>	If <code>output-device</code> is not set to the default value before the flash PROM update, then it is possible that the output device may be other than what you anticipate.
<code>input-device</code>	<code>keyboard</code>	If <code>input-device</code> is not set to the default value before the flash PROM update, then it is possible that the input device may be other than what you anticipate.
<code>ttyb-mode</code>	<code>9600,8,n,1,-</code>	If you are running anything from the serial ports A or B with port settings other than what is default (baud rate, number of bits, parity, number of stop bits, handshake), then those communications lines may not function after the flash PROM update.
<code>ttya-mode</code>	<code>9600,8,n,1,-</code>	If you are running anything from the serial ports A or B with port settings other than what is default (baud rate, number of bits, parity, number of stop bits, handshake), then those communications lines may not function after the flash PROM update.
<code>boot-command</code>	<code>boot</code>	If there are any custom flags to <code>boot</code> , then the system may not boot as anticipated after the flash PROM update.
<code>auto-boot?</code>	<code>true</code>	The system may attempt to autoboot after the first reset or power cycle following the flash PROM update. With <code>auto-boot?</code> set to <code>false</code> , the system will not autoboot.
<code>diag-switch?</code>	<code>true</code>	After you reboot or power cycle the system after the flash PROM update, the <code>diag-switch?</code> may be set to <code>true</code> . With <code>diag-switch?</code> set to <code>true</code> , diagnostics will be run at boot up. Also, the system may attempt to boot from a different device than was booted prior to the flash PROM update.
<code>diag-device</code>	<code>disk</code>	If you had <code>diag-switch?</code> set to <code>true</code> before the update then this is the device that would probably have been booted. This device might not be the boot device after the flash PROM update.
<code>diag-file</code>	Empty string	If you were booting a customized kernel file before the update, and <code>diag-switch?</code> was set to <code>true</code> after the flash PROM update, the customized kernel file might not be booted after the flash PROM update.

TABLE 6-4 (Continued)

Variable Name	Default Value	Description
<code>boot-file</code>	Empty string	If you were booting a customized kernel file before the flash PROM update, and <code>diag-switch?</code> was <code>false</code> (default), the customized kernel file might not be booted after the flash PROM update.
<code>boot-device</code>	<code>disk net</code>	If you had a different sequence of boot-devices specified, after the flash PROM update an incorrect device might be booted.
<code>use-nvramrc?</code>	<code>false</code>	If you had customized commands in the <code>nvramrc</code> , and <code>use-nvramrc?</code> was set to <code>true</code> , then those customized commands might not be used after the flash PROM update.
<code>nvramrc</code>	Empty	If you had customized commands in the <code>nvramrc</code> , then those customized commands might be lost after the flash PROM update. Do not use <code>setenv</code> to change the <code>nvramrc</code> variable. Instead use <code>nvedit</code> and <code>nvstore</code> . If you know that the <code>nvramrc</code> variable contains a firmware patch which is no longer compatible with the newly programmed firmware, do not change the <code>nvramrc</code> variable to its previously customized value.
<code>oem-logo?</code>	<code>false</code>	If <code>oem-logo?</code> was <code>true</code> before the flash PROM update, the <code>oem-logo</code> might be lost after the update, and <code>oem-logo?</code> might be set to <code>false</code> .
<code>oem-banner?</code>	<code>false</code>	If <code>oem-banner?</code> was <code>true</code> before the flash PROM update, the <code>oem-banner</code> might be lost after the flash PROM update, and <code>oem-banner?</code> might be set to <code>false</code> .

**15. Turn the keyswitch to the Standby position, wait a few seconds, and then power on again.**

This power-cycling flushes any old firmware code out of system memory.

If you set the `auto-boot?` NVRAM configuration variable to `true`, and the `boot-device` variable contains the device or device alias where the Solaris 8 4/01 operating environment was installed, then the system will boot the Solaris 8 4/01 operating environment. This concludes the flash PROM update procedure.

## Location of Flash PROM Jumpers in Sun Enterprise Server Systems

If you previously removed the write-protect/enable jumper, you must reinstall it in order to successfully perform the flash PROM update procedure.

Sun Enterprise 3x00, 4x00, 5x00, and 6x000 systems have a jumper on the clock board, P0601, which controls if the flash PROM can or cannot be updated.

- With the jumper P0601 *installed*, all the flash PROM *can* be updated.
- With the jumper P0601 *removed*, all the flash PROM *cannot* be updated.

If you previously removed jumper P0601, you must reinstall it before you can complete the flash PROM update procedure.

## Installing the P0601 Jumper

To install the P0601 jumper, follow these steps:

1. **Halt the system then turn the keyswitch to the Standby position.**

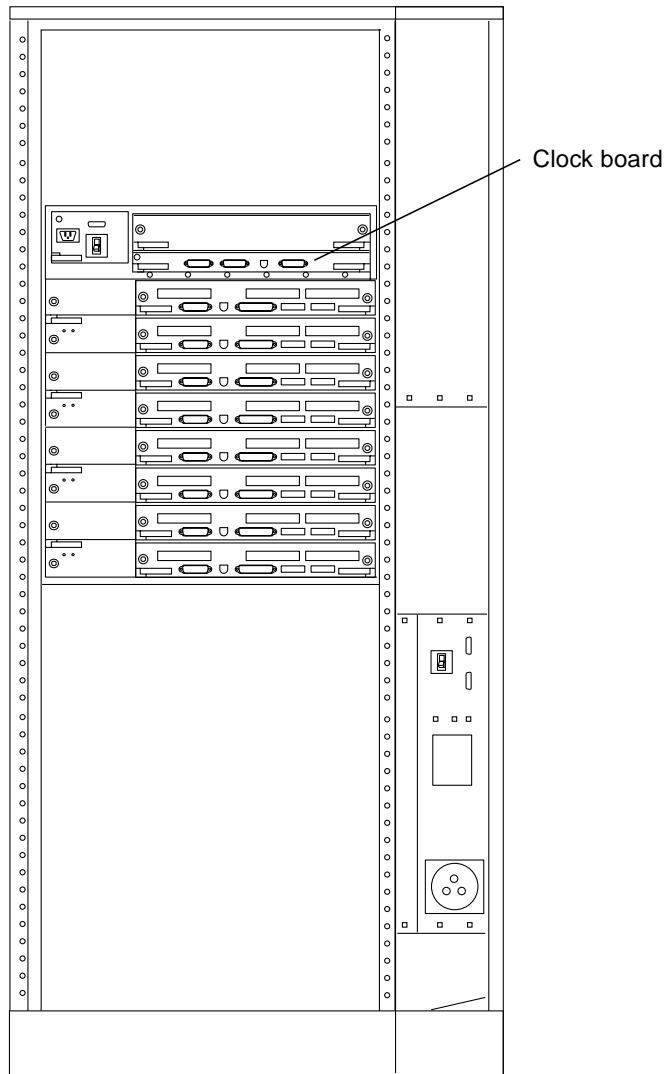


---

**Caution** – The clock board is not hot-pluggable. Do not remove the clock board until the system has been halted and powered off.

---

2. **Remove the clock board from the system (see FIGURE 6-2).**



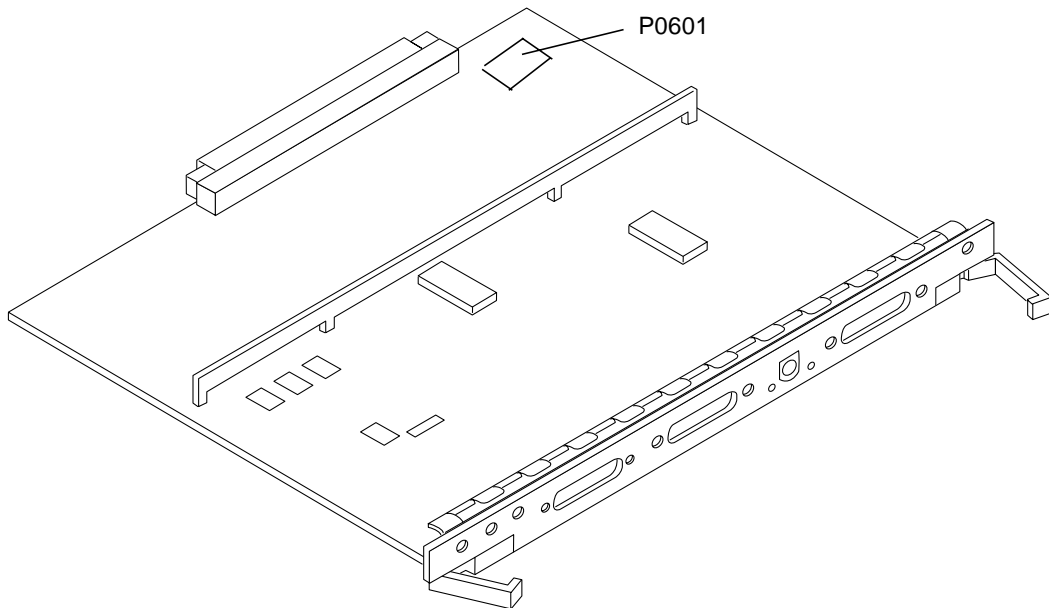
**FIGURE 6-2** Rear View of the Sun Enterprise 6000 System

---

**Note** – FIGURE 6-2 shows a 16-slot system. Systems also come in 4-, 5-, and 8-slot configurations.

---

**3. Locate the P0601 jumper location (FIGURE 6-3) on the clock board.**



**FIGURE 6-3** Clock Board and Jumper P0601 Jumper Location

- 4. Insert the P0601 jumper on the clock board.**
- 5. Replace the clock board in the system.**  
Refer to Chapter 6 in your reference manual for the detailed procedure.
- 6. Turn the keyswitch to the On or Diagnostics position.**

---

## Recovering From a Power Failure During the Flash PROM Update

If the power was lost during the flash PROM update, complete the power interruption recovery procedure for your system.

### Sun Enterprise 3x00, 4x00, 5x00, and 6x00 Systems

There are three scenarios for the Sun Enterprise 3x00, 4x00, 5x00, and 6x00 systems:



- Completing the update of the flash PROM
- Recovering a one-board system after power interruption
- Recovering a multi-board system after power interruption

## ▼ To Complete the Update of the Flash PROM

If power was interrupted during the flash PROM update procedure, it is possible that one or more system boards were not updated successfully. You must become superuser and complete the flash PROM update.

1. **At the # prompt, type the following:**

```
# /bin/sh /usr/platform/sun4u/lib/prom/`uname -i`
```

## ▼ To Recover a One-Board System After Power Interruption

1. **Call your Sun service provider or local Sun service Authorized Service Provider.**

## ▼ To Recover a Multi-Board System After Power Interruption

Only one board is updated at any given time in the flash PROM updating process. If there is a power interruption to the system while the flash PROMs are being updated, only one board will have its flash PROMs in an inconsistent state.

---

**Note** – Power interruption during updating of the flash PROMs aborts the updating at the point of the power interruption. Turn the keyswitch to the Standby position (FIGURE 6-1 on page 84) to prevent power surge to the system when power is restored.

---

The following recovery procedure requires another board of the same type with an uncorrupted PROM image (if you are updating an “I/O Type 1” board, you must use another “I/O Type 1” board). In the following code examples, the flash PROM on board 3 recovers by copying the flash PROM image from board 0.

1. **Connect a null modem cable to port A and to either a terminal or a Sun™ Workstation™.**
2. **Set the serial port at 9600 bps, 8-bit word, no parity, and 1 stop bit.**
3. **Remove the board that was being programmed when the power went out.**
4. **Turn the keyswitch to the On position (FIGURE 6-1 on page 84).**

The system responds with the message:

```
Hardware Power ON
```

1. **Wait 15 seconds and type `s` on the keyboard terminal or the tip window connected to the serial port.**

The system responds:

```
0,0>  
*** Toggle Stop POST Flag = 1 ***
```

This message shows that POST (power-on self-test) has recorded your request to stop after testing is completed.

When POST stops, it will display the following options menu:

```
0,0>Extended POST Menu  
0,0>Select one of the following functions  
0,0>  '0'      Return  
0,0>  '1'      Reset  
0,0>  '2'      Peek/Poke device  
0,0>  '3'      Environmental Status  
0,0>  '4'      Test Menus  
0,0>  '5'      State Dump  
0,0>  '6'      Frequency Margining  
0,0>  '7'      Display System Summary  
0,0>  '8'      Display Fatal Reset Info  
0,0>  '9'      Scan System Board Ring  
0,0>  'a'      Set Memory Test Megs  
0,0>  'b'      Print SIMM Info  
0,0>  'c'      Focus CPU  
0,0>  'd'      CPU State  
0,0>  'f'      fcopy  
0,0>  'g'      System Power Off  
0,0>  'h'      Bounce Patterns  
0,0>  'i'      Focus I/O Board  
0,0>
```

**1. Type f to select fcopy.**

```
Command ==> f
0,0>Flash PROM Copy Menu
0,0>Select one of the following functions
0,0>   '0'      Return
0,0>   '1'      Copy
0,0>   '2'      Verify
0,0>   '3'      Display Version
0,0>   '4'      Activate System Board
0,0>

Command ==>
```

**2. Without powering off the system, plug in the board with the corrupted flash PROM. Be sure its power LED is lit.**

**3. Type 4 to select Activate System Board.**

The system prompts you to enter the board number in hexadecimal notation from 0 through 9 and “a” through “f”. In the example below, board 3 is entered as the board to be activated.

```
Command ==> 4
0,0>Input board number in hex ('0' thru '9' and 'a' thru 'f')
?3
0,0>
0,0>Flash PROM Copy Menu
0,0>   '0'      Return
0,0>   '1'      Copy
0,0>   '2'      Verify
0,0>   '3'      Display Version
0,0>   '4'      Activate System Board
0,0>

Command ==>
```

- 4. Type 1 to select Copy. Respond to the prompts for source (where to copy from) and destination (where to copy to) board numbers in hexadecimal notation.**

In the example below, board 0 is entered as the source and board 3 is entered as the destination:

```
Command ==> 1
0,0>Input board number in hex ('0' thru '9' and 'a' thru 'f')
0,0>
from board? 0
to board? 3
0,0>    Mfg code 04, Dev code a4
0,0>Erasing prom at 000001cc.f8000000
0,0>Copy prom at 000001c0.f8000000 to prom at 000001cc.f8000000
0,0>.....
0
```

- 5. Type 3 to select Display Version.**

The system responds by showing all PROM versions in the system.

```
Command ==> 3
0,0>Slot 0 CPU/Memory  OBP      3.2.1 1996/3/11 09:57 POST   3.0.1
1996/3/11 18:38
0,0>Slot 1 IO Type 1   FCODE   1.6.0 1996/1/23 13:44 iPOST  1.1.4
1996/3/05 04:06
```

- 6. Turn the keyswitch to the Standby position (FIGURE 6-1). Wait 15 seconds.**
- 7. Complete the procedure “To Update the Flash PROM” on page 85 to reattempt the flash PROM update process.**

## Power Management on Sun Hardware

---

The United States Environmental Protection Agency has the Energy Star® guidelines for computer products to encourage the use of energy-efficient computer systems and to reduce air pollution associated with energy generation.

To meet these guidelines, Sun Microsystems, Inc. designs hardware to use power efficiently; also, it provides Power Management™ software with which to configure the power management settings. In order to reduce power consumption, your Sun workstation and devices are capable of entering a lower-power state when they have been inactive for a period of time.

This section supplements the *Using Power Management* manual in the Solaris 8 User Collection.

---

## Supported Platforms and System Distinctions

Power Management software supports the sun4m and sun4u platform groups. Software features and defaults may vary between the two platform groups. Refer to *Using Power Management* in the Solaris 8 User AnswerBook set for more information when you identify the platform group that applies to your system.

---

**Note** – Power Management does not support the sun4c and sun4d platform groups.

---

**TABLE 7-1** Platform Names and Groups Supported by Power Management

Sun System Name	Platform Name	Platform Group
SPARCstation 4	SUNW, SPARCstation-4	sun4m
SPARCstation 5	SUNW, SPARCstation-5	sun4m
SPARCstation 10	SUNW, SPARCstation-10	sun4m
SPARCstation 10SX	SUNW, SPARCstation-10, SX	sun4m
SPARCstation 20	SUNW, SPARCstation-20	sun4m
SPARCstation LX	SUNW, SPARCstation-LX	sun4m
SPARCstation LX+	SUNW, SPARCstation-LX+	sun4m
SPARCclassic	SUNW, SPARCclassic	sun4m
SPARCclassic X	SUNW, SPARCclassic-X	sun4m
Ultra 1 (all models)	SUNW, Ultra-1	sun4u
Ultra 5	SUNW, Ultra-5	sun4u
Ultra 10	SUNW, Ultra-10	sun4u
Ultra 30	SUNW, Ultra-30	sun4u
Ultra 60	SUNW, Ultra-60	sun4u
Ultra 450	SUNW, Ultra-4	sun4u
Ultra 2 Creator (all models)	SUNW, Ultra-2	sun4u
Sun Enterprise 1 Model 140	SUNW, Ultra-1	sun4u
Sun Enterprise 1 Model 170	SUNW, Ultra-1	sun4u
Sun Enterprise 1 Model 170E	SUNW, Ultra-1	sun4u
Sun Enterprise 2 Model 1300	SUNW, Ultra-2	sun4u
Sun Enterprise 2 Model 2300	SUNW, Ultra-2	sun4u

---

**Note** – The SPARCstation™ Voyager is a sun4m-architecture system, but it is not supported in this Solaris release.

---

# System Architecture Distinctions and Default Settings

The SPARC architecture of a workstation determines which Power Management features are available. To determine your system's architecture, see TABLE 7-1. The default behavior in Power Management functions varies on systems, as described in TABLE 7-2.

**TABLE 7-2** Power Management Features in Different SPARC Architectures

Power Management Features	sun4m	sun4u (Energy Star 2.0)	sun4u (Energy Star 3.0)	Servers
Display PM Available	Yes	Yes	Yes	Yes
Display PM by Default	Yes	Yes	Yes	Yes
Device PM Available	No	No	Yes	No
Device PM by Default	N/A	N/A	Yes	N/A
Suspend-Resume Available	Yes	Yes	Yes	No
Suspend-Resume by Default	No	Yes	No	N/A
AutoShutDown Available	No	Yes	Yes	No
AutoWakeup by Default	N/A	Yes	No	N/A

---

## SPARCstation 4 Issues

This section describes a workaround to a limitation of the SPARCstation 4 when used with Power Management.

The AC accessory outlet on the SPARCstation 4 system is an unswitched outlet. The AC power switch does not control power flowing through the accessory outlet. If you connect a monitor to the accessory outlet, you cannot turn it off using the system unit power switch. Similarly, if you use Power Management software, the software cannot turn off the monitor automatically. To conserve energy, consider using an Energy Star-compliant monitor. Sun offers a variety of Energy Star-compliant monitors in its standard SPARCstation 4 system configurations. This information does not apply to SPARCserver 4 configurations. The SPARCserver 4 includes a switched accessory outlet.





## Alternate Pathing 2.3.1 on the Sun Enterprise servers

---

This chapter contains initial installation and upgrade instructions for Alternate Pathing (AP) 2.3.1. With the introduction of AP 2.3.1, both the initial install instructions and the upgrade instructions now apply to the Sun Enterprise™ 3x00, 4x00, 5x00, 6x00 and 10000 servers.

---

### Preparing to Install or Upgrade

The AP packages require approximately 2.7 megabytes of disk space on the server. The following table lists the total size of the AP software by file system.

**TABLE 8-1** AP Software Approximate File System Sizes

File System	Size
/usr	317 Kbytes
/	1.3 Mbytes
/etc	13 Kbytes
/kernel	1528 Kbytes
/sbin	1481 Kbytes

AP requires that an entire disk partition with at least 300 Kbytes be dedicated to each database copy. For more detailed information on partitioning for the AP databases, see Chapter 2, “Alternate Pathing Database” in the *Alternate Pathing 2.3.1 User Guide*.

The installation instructions in this section assume that your system is running the Solaris 2.6, Solaris 7 or Solaris 8 operating environment. AP 2.3.1 will not run under software releases earlier than Solaris 2.6 environment.

## ▼ To Install or Upgrade From the Web

1. **Using your web browser, go to** <http://www.sun.com/servers/sw/>
2. **Click the Enterprise Alternate Pathing (AP) link.**
3. **Click the** [Click here to download link](#).  
The file that is then downloaded is named `ap_2_3_1_sparc.zip`.
4. **Log in as superuser.**
5. **Change directory to the location where you downloaded the software:**

```
# cd /download_directory
```

6. **Extract the downloaded file by typing:**

```
# unzip -v ap2_3_1_sparc.zip
```

The AP 2.3.1 packages are located in `/download_directory/ap_2_3_1_sparc/Product` and the install and upgrade scripts are located in `/download_directory/ap_2_3_1_sparc/Tools`.

7. **Proceed to “Performing an Initial Installation of AP” on page 109 or “Before Performing an Upgrade of AP” on page 122.**

## ▼ To Install or Upgrade From a CD-ROM

1. **Insert the “Software Supplement for the Solaris 8 Operating Environment” CD-ROM into the CD-ROM drive.**  
Allow time for the volume manager to mount the CD-ROM.

---

**Note** – If your CD-ROM is not local to your system (for example, on a Sun Enterprise 10000) and you are not familiar with remote installation using a CD-ROM, see “To Mount a CD-ROM over NFS™” on page 107 or refer to your *Solaris System Administration Guide*.

---

The AP 2.3.1 packages are located in:

```
/cdrom/cdrom0/Alternate_Pathing_2.3.1/Product
```

The install and upgrade scripts are located in:

```
/cdrom/cdrom0/Alternate_Pathing_2.3.1/Tools
```

- 2. Become superuser and cd to the Product installation directory:**

```
# cd /cdrom/cdrom0/Alternate_Pathing_2.3.1/Product
```

- 3. Proceed to “Performing an Initial Installation of AP” on page 109 or “Before Performing an Upgrade of AP” on page 122.**

## ▼ To Mount a CD-ROM over NFS™

- 1. Log in as superuser and verify that the volume manager is running on your machine:**

```
# ps -ef | grep vold
```

- 2. If you see an entry containing /usr/sbin/vold, volume manager is running on your system.**
  - If volume manager is running, skip to Step 3.
  - If volume manager is not running on your system, type:

```
# /etc/init.d/volmgt start
```

- 3. Check to see if NFS is running on your system:**

```
# ps -ef | grep nfsd
```

- If you see an entry containing `/usr/lib/nfs/nfsd` then `nfsd` is running on your system. Type:

```
# share -F nfs -o ro /cdrom/cdrom0/Alternate_Pathing_2.3.1
```

- If `nfsd` is not running, type:

```
# /etc/init.d/nfs.server start
# share -F nfs -o ro /cdrom/cdrom0/Alternate_Pathing_2.3.1
```

#### 4. Log in to target machine as superuser and `cd` to the source machine:

```
# cd /net/source_machine/cdrom/cdrom0/Alternate_Pathing_2.3.1
```

If you cannot change to that directory and you do not have automounter on your network, create a mount point on the target machine and mount the `Product` directory:

```
# mkdir /remote_products
# /usr/sbin/mount -F nfs -r source_machine:/cdrom/cdrom0/
Alternate_Pathing_2.3.1 /remote_products
# cd /remote_products
```

#### 5. At this point you may proceed with the install, “Performing an Initial Installation of AP” on page 109 or “Before Performing an Upgrade of AP” on page 122.

Once you have completed installation you can `umount` the CD-ROM using:

```
# umount source_machine/cdrom
```

---

# Performing an Initial Installation of AP

The initial installation instructions in this section are for environments where AP is not currently installed and configured. If any version of AP is currently installed and configured, you can use the instructions in “Before Performing an Upgrade of AP” on page 122 to install AP 2.3.1. That procedure uses scripts that save your current AP configuration, and then restores that configuration after you install the AP 2.3.1 packages.

The installation instructions in this section assume that your system is running the Solaris 2.6, Solaris 7 or Solaris 8 operating environment. AP 2.3.1 will not run under software releases earlier than the Solaris 2.6 environment.

---

**Note** – AP 2.3.1 software installation is based on your operating environment. If, at a later date, you upgrade your Solaris operating environment, you must re-install AP 2.3.1 following the AP 2.3.1 upgrade procedure. See “Before Performing an Upgrade of AP” on page 122. For information on performing a simultaneous upgrade, see “Simultaneously Upgrading AP and Solaris Software” on page 124.

---

## ssd Patch

AP 2.3.1 requires an `ssd(7D)` patch. AP 2.3.1 installation checks for the presence of this patch. If the patch is not present then, depending on your configuration, the following message maybe displayed:

```
Alternate Pathing Subsystem Drivers
(sparc) 2.3.1,REV=2000.05.09.11.28
Copyright 2000 Sun Microsystems, Inc. All rights reserved.
## Executing checkinstall script.
Determining patch requirements...
Verifying required patches are installed...
Required patches not installed: 109524-01
###
### Patch verification failed.
### Alternate Pathing 2.3.1 requires this package.
### You MUST apply the required patches before
### proceeding.
###
### PACKAGE INSTALLATION FAILED.
###
checkinstall script suspends

Installation of <SUNWapdv> was suspended (administration).
No changes were made to the system.
```

The required patches are as follows:

- Patch 105356-15 for Solaris 2.6,
- Patch 107458-09 for Solaris 7
- Patch 109524-01 for Solaris 8

You can obtain these patches from SunSolve at: <http://sunsolve.sun.com>.

---

**Note** – For information on this patch, see Section “Fixed Other Bugs” on page 35 (Sun BugID 4295457).

---

You can use Web Start to install the AP 2.3.1 software and optionally the AP 2.3.1 AnswerBook2 collection or you can manually install the AP and AnswerBook packages using `pkgadd`.

To manually install AP 2.3.1 proceed to “To Manually Install AP 2.3.1” on page 113. To manually install the AP 2.3.1 AnswerBook see “To Install the AP 2.3.1 AnswerBook2 Collection” on page 120.

If you have a third party volume manager installed on your system, you must deconfigure it, according to your vendor's instructions, before installing AP 2.3.1. Once you have finished deconfiguring or if you do not have a volume manager installed, proceed to "To Install AP 2.3.1 Using Web Start" on page 111 for the Web Start procedure or "To Manually Install AP 2.3.1" on page 113 for the manual procedure.

## ▼ To Install AP 2.3.1 Using Web Start

You can use Web Start to perform a fresh install from CD-ROM or from files you have downloaded from the Web.

1. **Log in as superuser.**
2. **Set the `DISPLAY` environment variable.**

For `sh(1)` or `ksh(1)`, type:

```
# DISPLAY=hostname:0
# export DISPLAY
```

Where *hostname* is the host name of the machine used to graphically display Web Start.

3. **Change directory to the location of the AP 2.3.1 package:**

- If you downloaded software from the Web:

```
# cd /download_directory/ap_2_3_1_sparc/Product
```

- If you are installing the upgrade from the CD-ROM:

```
# cd /cdrom/cdrom0/Alternate_Pathing_2.3.1/Product
```

4. **Begin Web Start by typing:**

```
# ./installer
```

5. **Select Custom Install, then select the Alternate Pathing 2.3.1 software and optionally the Alternate Pathing 2.3.1 AnswerBook2 product.**

With custom installation, only the products that you select are installed.

---

**Note** – You can install the packages in any order you wish but you must install them all. Package installation depends on the `ssd` patch being present. See “`ssd Patch`” on page 110 for more information

---

**6. Verify that you have sufficient disk space to cover the requirements displayed on the Ready to Install dialog.**

**7. Click the Install Now button.**

Wait until the installation is complete and the Installation Summary dialog is displayed.

---

**Note** – If your Sun Enterprise server is not configured to support a particular feature or device that is supported by Alternate Pathing, simply adding AP to your server will not enable it to use that feature or device.

---

**8. Configure AP.**

For an example of the steps you need to follow, see “To Configure AP” on page 10. Also see the *Alternate Pathing 2.3.1 User Guide*.

---

**Note** – If you are using IPv6, your `/etc/hostname` files will have the name `/etc/hostname6.xxx`. While the content of the IPv6 files is different than IPv4, as far as AP installation is concerned, the `/etc/hostname6.xxx` files can be treated in exactly the same manner as the `/etc/hostname.xxx` files. For more information on IPv6 refer to *System Administration Guide, Volume 3*.

---



## ▼ To Manually Install AP 2.3.1

1. Log in as superuser.
2. Change directory to the location of the AP 2.3.1 package:
  - If you downloaded software from the Web:

```
# cd /download_directory/ap_2_3_1_sparc/Product
```

- If you are installing the upgrade from the CD-ROM:

```
# cd /cdrom/cdrom0/Alternate_Pathing_2.3.1/Product
```

3. Install the AP 2.3.1 domain packages on the server:

```
# pkgadd -d . SUNWapdoc SUNWapdv SUNWapr SUNWapu
```

---

**Note** – You can install the packages in any order you wish but you must install them all. Package installation depends on the `ssd` patch being present. See “`ssd Patch`” on page 110 for more information

---

The software briefly displays copyright, trademark, and license information for each package, then displays messages about `pkgadd(1M)` actions taken to install the package, including a list of the files and directories being installed. Depending on your configuration, the following messages may be displayed:

```
This package contains scripts which will be executed  
with superuser permission during the process of installing this  
package.
```

```
Do you want to continue with the installation of this  
package [y,n,?]
```

Type **y** at each successive prompt to continue.

When this portion of the installation is complete, the AP 2.3.1 packages have been installed and the superuser prompt is displayed.

---

**Note** – If your Sun Enterprise server is not configured to support a particular feature or device that is supported by Alternate Pathing, simply adding AP to your server will not enable it to use that feature or device.

---

**4. Remove the Sun Computer Systems Supplement CD from the CD-ROM drive, if applicable:**

```
# cd /
# eject cdrom
```

**5. Configure AP.**

For an example of the steps you need to follow, see “To Configure AP” on page 10. Also see the *Alternate Pathing 2.3.1 User Guide*.

---

**Note** – If you are using IPv6, your `/etc/hostname` files will have the name `/etc/hostname6.xxx`. While the content of the IPv6 files is different than IPv4, as far as AP installation is concerned, the `/etc/hostname6.xxx` files can be treated in exactly the same manner as the `/etc/hostname.xxx` files. For more information on IPv6 refer to *System Administration Guide, Volume 3*.

---

▼ **To Configure AP**

**1. Create three to five AP databases:**

```
# apdb -c raw_disk_slice
```

---

**Note** – See the *Alternate Pathing 2.3.1 User Guide* for information on disk partitions for the AP database.

---

**2. Create the AP metadisks.**

You must know the configuration of the host hardware so that you know which two ports are connected to the same disk array. The following steps use `sf` ports. Your ports may vary, depending on the configuration of the host.

**a. Display all of the ports and their disk device nodes:**

```
# apinst
sf:0
  /dev/dsk/c1t0d0
  /dev/dsk/c1t1d0
  /dev/dsk/c1t2d0
  /dev/dsk/c1t3d0
  /dev/dsk/c1t4d0
  /dev/dsk/c1t5d0
sf:1
  /dev/dsk/c2t0d0
  /dev/dsk/c2t1d0
  /dev/dsk/c2t2d0
  /dev/dsk/c2t3d0
  /dev/dsk/c2t4d0
  /dev/dsk/c2t5d0
```

**b. Create an uncommitted disk pathgroup:**

```
# apdisk -c -p sf:0 -a sf:1
# apconfig -S -u
```

where:

-c causes the pathgroup to be created

-p designates the primary path

-a designates the alternate path

You can verify the results by using `apconfig(1M)` as shown above.

**c. Commit the database entries:**

```
# apdb -C
```

As shown, you can verify the results of that command by using `apconfig -S`.

- d. If you are placing the boot disk under AP control, use `apboot(1M)` to define the new AP boot device:

```
# apboot metadisk_name
```

The `apboot(1M)` command modifies the `/etc/vfstab` file and the `/etc/system` file. The `metadisk_name` must be in the form: `mcxtxdx`.

- e. **Modify any references that use a physical device node (that is, a path that begins with `/dev/dsk` or `/dev/rdisk`) to use the corresponding metadisk device node (that is, a path that begins with `/dev/ap/dsk` or `/dev/ap/rdisk`).**

If a partition is mounted under a physical path, unmount and remount it under the metadisk path using `umount` and `mount` respectively.

Examine `/etc/vfstab` for any physical devices that should be changed to AP metadevices. If necessary, edit `/etc/vfstab` to make the necessary modifications.



---

**Caution** – You must be a knowledgeable system administrator to edit `/etc/vfstab`. If you do not configure your file systems properly in `/etc/vfstab`, it is possible that you can lose data and/or leave the server unbootable.

---

### 3. Create AP metanetworks (for nonprimary networks).

---

**Note** – The following steps should be applied to all networks that you want to alternately path *except* the primary network.

---

#### a. Create the network pathgroup:

```
# apnet -c -a network_interface -a network_interface
# apconfig -N -u
...
```

As shown, you can verify the results of the `apnet(1M)` command by using `apconfig(1M)`.

#### b. Commit the network pathgroup entries in the database.

```
# apdb -C
```

You can verify the results of the `apdb(1M)` command by using the `apconfig(1M)` command with the `-N` option.

#### c. Remove all direct usage of both members of the network pathgroups.

If the physical interface is currently plumbed, and it is not the interface that you will be using as you run commands to configure the metanetwork, you can unplumb the physical interface by using the `ifconfig(1M)` command.

#### d. Create an `/etc/hostname.metherx` (for example, `hostname.mether0`) file for any metanetworks that you want to configure when the server is rebooted.

---

**Note** – If you are using IPv6, your `/etc/hostname` files will have the name `/etc/hostname6.xxx`. While the content of the IPv6 files is different than IPv4, as far as AP installation is concerned, the `/etc/hostname6.xxx` files can be treated in exactly the same manner as the `/etc/hostname.xxx` files. For more information on IPv6 refer to *System Administration Guide, Volume 3*.

---

#### 4. Create the AP metanetwork for the primary network.

- a. **View the contents of the `/etc/nodename` and `/etc/hostname.xxx` files (for example, `hostname.hme0`) to verify that the interface name is the same.**

---

**Note** – If you are using IPv6, your `/etc/hostname` files will have the name `/etc/hostname6.xxx`. While the content of the IPv6 files is different than IPv4, as far as AP installation is concerned, the `/etc/hostname6.xxx` files can be treated in exactly the same manner as the `/etc/hostname.xxx` files. For more information on IPv6 refer to *System Administration Guide, Volume 3*.

---

#### b. Create the primary network pathgroup:

```
# apnet -c -a network_interface1 -a network_interface2
```

where:

- c creates the new primary network pathgroup
- a designates the first alternate network path
- a designates the second alternate network path

#### c. Commit the network pathgroup entry in the database:

```
# apdb -C  
# apconfig -N
```

As shown, you can verify the results of the `apdb(1M)` command by using `apconfig(1M)`.

#### d. Rename the `/etc/hostname.xxx` file to `/etc/hostname.metherx` to configure the network when you reboot the server.

For example:

```
# mv hostname.hme0 hostname.mether0
```

5. **If you plan to use a volume manager, such as Solstice DiskSuite™ (SDS) or VERITAS Volume Manager™ (VxVM) configure the volume manager according to the vendor's instructions.**

---

**Note** – Make sure that your volume manager is supported under your version of the Solaris operating environment (either version 2.6, version 7, or version 8).

---

- **SDS Issues**

If you want to build your SDS volumes on top of AP, configure your volumes using AP metadisk paths rather than physical paths. SDS recognizes and properly installs on existing AP metadisks with no special action required.

- **VxVM Issues**

If you want to build your VxVM volumes on top of AP, configure your volumes using AP metadisk paths rather than physical paths. VxVM recognizes and properly installs on existing AP metadisks with no special action required.

VxVM can encapsulate both nonboot disks and boot disks that are configured as AP metadisks. VxVM can encapsulate AP databases without any impact on AP. Note, however, that the standard VxVM requirements for encapsulation apply:

- There must be an `s2` slice that represents the entire disk.
- There must be two free partitions. The partition requirement may necessitate giving up an AP database, which is often placed in slice `s4`.
- There must be a "small amount" of free disk space at the beginning or end of the disk.

Software installation of VxDMP and AP are mutually exclusive. You can only install one or the other. VxDMP does not work with DR.

6. **Reboot the server (if necessary).**

If you just rebooted the server after configuring a volume manager, this step is unnecessary.

---

## Installing the AP 2.3.1 AnswerBook2 Collection

This section explains how to manually install the AP 2.3.1 AnswerBook2 document collection using the standard installation utility, `pkgadd`.

## AP 2.3.1 AnswerBook2 Collection

Before you can install the AP 2.3.1 AnswerBook2 document collection, you must have the AnswerBook2 server software installed. For instructions on installing the AnswerBook2 server software, see “Installing and Administering an AnswerBook2 Server” in the AnswerBook2 Help Collection on [docs.sun.com](http://docs.sun.com). The server software can be obtained from the following sources:

- The Documentation CD for Solaris 7 and Solaris 8 environments
- The Web (<http://www.sun.com/software/ab2/index.html>)

### ▼ To Install the AP 2.3.1 AnswerBook2 Collection

1. **Log in as superuser on the machine where the AP 2.3.1 AnswerBook2 collection is to be installed.**
2. **If you have a previous version of the SUNWabap package installed, remove it using the `pkgrm` command:**

```
# pkgrm SUNWabap
```

3. **Change directory to the location of the AP 2.3.1 AnswerBook package:**

- If you downloaded software from the Web:

```
# cd /download_directory/ap_2_3_1_sparc/Product
```

- If you are installing the upgrade from the CD-ROM:

```
# cd /cdrom/cdrom0/Alternate_Pathing_2.3.1/Product
```

4. **Add the SUNWabap package by typing:**

```
# pkgadd -d . SUNWabap
```

5. **When you are requested to select an installation option, type 2 (heavy installation):**

```
Select an installation option: 2
```



- 6. When you are asked to specify the parent path for the AnswerBook2 collection, type the path to the directory in which you want to put the AP 2.3.1 AnswerBook2. It is suggested that you install the AP AnswerBook2 Collection in /opt.**

```
Specify the parent path of this AnswerBook2 Collection directory: /opt
```

- 7. Type y at the following prompt:**

```
This package contains scripts which will be executed with super-user  
permission during the process of installing this package.
```

```
Do you want to continue with the installation of <SUNWabap> [y,n,?] y
```

A message indicates that the SUNWabap package was successfully installed.

For instructions on launching the AnswerBook2 viewer and viewing document collections, see “Viewing Online Documentation Using the AnswerBook2 System” in the AnswerBook2 Help Collection on [docs.sun.com](http://docs.sun.com).

---

# Before Performing an Upgrade of AP

This section provides information and recommendations concerning an upgrade to AP 2.3.1 on the Sun Enterprise servers.

AP 2.0, 2.0.1, 2.1 and 2.2 are not supported under the Solaris 8 10/00 operating environment.

The upgrade process involves:

- Saving your current configuration
- Deconfiguring AP
- Removing the earlier version of AP
- Installing a set of core AP packages
- Restoring your AP configuration

Scripts are provided to simplify this process in */download\_directory/ap\_2\_3\_1\_sparc/Tools* from the web or on CD-ROM in */cdrom/cdrom0/Alternate\_Pathing\_2.3.1/Tools*.

---

**Note** – If you are upgrading to AP 2.3.1 on *all* Sun Enterprise 10000 domains, then you can safely remove the `SUNWapssp` package software from the SSP workstation using `pkgrm`. If, however, any domain will remain at an earlier version of AP, then you must *not* remove the AP software on the SSP workstation. In either case, leaving AP software on SSP workstations will have *no* effect on AP 2.3.1.

---

Installation of the packages requires approximately 2.7 megabytes of disk space. The following table lists the total size of the AP software by file system.

**TABLE 8-2** AP Software File System Sizes

File System	Size
<code>/usr</code>	317 Kbytes
<code>/</code>	1.3 Mbytes
<code>/etc</code>	13 Kbytes
<code>/kernel</code>	1528 Kbytes
<code>/sbin</code>	1481 Kbytes

---

**Note** – When partitioning the hard drive during the Solaris software installation, you must dedicate an entire disk partition with at least 300 Kbytes to each database copy. For more detailed information on partitioning for the AP databases, see Chapter 2, “Alternate Pathing Database” in the *Alternate Pathing 2.3.1 User Guide*.

---

## Backing Up Your Server

Always back up an existing server before you upgrade any software. The safest backup to perform is a level 0 dump (`ufsdump(1M)`) of the file systems connected to the server being upgraded. If you do not have an established backup procedure, see the *System Administration Guide*.

You do not need to back out installed patches before you perform the upgrade.

---

**Note** – If you wish to add or remove any hardware included in an AP path group, do so either *before* you begin the upgrade process or *after* you have completed it. In general, avoid changing your hardware in ways that result in controller renumbering.

---

## Uncommitted AP Database Entries

Before you run `ap_upgrade_begin`, commit any uncommitted entries in the AP database. Any metadevices that were created but not committed are not preserved during the upgrade. Similarly, any metadevices that were deleted but not committed will continue to exist after the upgrade.

## Checking Other Software Documentation

Check the documentation of other software you are running, such as disk volume managers, before you use the `upgrade` option in the `suninstall` utility. There may be additional instructions you need to follow to preserve existing configurations. Also, be sure to check the release notes for AP and any volume managers you are using.

# Simultaneously Upgrading AP and Solaris Software

The AP upgrade procedures in this section use two scripts, `ap_upgrade_begin` and `ap_upgrade_finish`. The first script saves your current AP configuration. The second script restores that exact configuration after you install the AP 2.3.1 packages. It is possible that you will upgrade the Solaris software at the same time you upgrade to AP 2.3.1, since AP 2.3.1 supports Solaris 2.6, Solaris 7, and Solaris 8. Because the AP configuration is restored exactly as it was before you upgraded the Solaris operating environment, you need to be aware of the issues described in the following sections.

## AP Database Partitions

The AP upgrade scripts attempt to recreate the AP databases in the same partitions that they occupied before the upgrade of the Solaris operating environment. Note, however, that Solaris 7 and Solaris 8 require more disk space than earlier versions of the Solaris operating environment. Because of this, you can choose to modify the boot disk partitioning scheme during `suninstall`. Do *not* modify the AP database partitions. If you are upgrading from Solaris 7 to Solaris 8 operating environment this will not be an issue. If, however, you are upgrading from an earlier version of Solaris and you place file systems in all partitions that were previously used for AP databases, `ap_upgrade_finish` is not able to recreate any databases and the upgrade process fails.



---

**Caution** – If you place a file system in *any* partition that was previously used for an AP database, and if for some reason that file system is not mounted at the time you run `ap_upgrade_finish`, that file system is overwritten by a copy of the AP database.

---

## Root Disk Partitions

The AP upgrade facility assumes that the partitioning of the root disk (the disk containing the / (root) partition) is not modified during the upgrade. Solaris 7 and Solaris 8 software require more disk space than earlier versions. One way to acquire the additional space is to repartition the original disk or to split the root disk into two disks using standard commands prior to the Solaris upgrade. If you need to repartition the root disk, do so *before* performing the AP 2.3.1 upgrade procedure.

If there is insufficient space when you run `suninstall`, you have the option to modify the disk partitioning layout to acquire more space. However, during `suninstall`, you must not relocate the `/` (root) or `/usr` partitions to another disk as this will cause the AP upgrade script to fail.

## ssd Patch

AP 2.3.1 requires an `ssd(7D)` patch. AP 2.3.1 installation checks for the presence of this patch.

The required patches are as follows:

- Patch 105356-15 for Solaris 2.6,
- Patch 107458-09 for Solaris 7
- Patch 109524-01 for Solaris 8

You can obtain these patches from SunSolve at: <http://sunsolve.sun.com>.

---

# Performing an Upgrade of AP

The upgrade installation instructions in this section are for environments where AP is currently installed and configured.

---

**Note** – If your Sun Enterprise server is not configured to support a particular feature or device that is supported by Alternate Pathing, simply adding AP to your server will not enable it to use that feature or device.

---

The installation instructions in this section assume that your system is running the Solaris 2.6, Solaris 7 or Solaris 8 operating environment. AP 2.3.1 will not run under software releases earlier than Solaris 2.6 environment.

---

**Note** – AP 2.3.1 software installation is based on your operating environment. If, at a later date, you upgrade your Solaris operating environment, you must re-install AP 2.3.1 following this AP 2.3.1 upgrade procedure. See “Before Performing an Upgrade of AP” on page 122. For information on simultaneous upgrade, see “Simultaneously Upgrading AP and Solaris Software” on page 124.

---

## ▼ To Upgrade to AP 2.3.1

1. If necessary, log in as superuser and commit any uncommitted entries in the AP database:

```
# apdb -C
```

2. Terminate any processes that directly or indirectly access AP metadevices.

If you have a third party volume manager installed on your system, deconfigure it now using the documentation provided by the specific vendor.

With regard to AP, no additional steps need to be taken to do this other than those recommended by the manufacturer to deconfigure the volume manager.



---

**Caution** – Once the volume manager has been deconfigured, if you are instructed to install the new OS, stop at that point and remove your previous version of AP. Do *not* install Solaris 8 software at this time.

---

You do not need to be concerned if your mounted `ufs` file systems or TCP/IP networks are using AP metadevices.

The `ap_upgrade_begin` script, which you will run later in this procedure, and the subsequent `reboot` will cause the `ufs` file systems and any swap devices configured in `/etc/vfstab` to use physical paths rather than AP metadevices.

Likewise, `ap_upgrade_begin` will also take care of renaming any TCP/IP network interfaces (`/etc/hostname.xxx`) that may be using AP metadevices.

---

**Note** – This is true for any `ufs` file system configured in `vfstab` or any network configured with `/etc/hostname.xxx` files.

---

3. Remove the current AP configuration.

- a. **Log in to the server as superuser and run the following script to deconfigure AP (and save the AP configuration so that it can be restored later):**

```
# /path/Alternate_Pathing_2.3.1/Tools/ap_upgrade_begin
...
ap_upgrade_begin complete. (State saved in /var/tmp/apstate.) Now
you can safely remove the old AP packages, upgrade Solaris if
necessary, and install new AP packages. Run the ap_upgrade_finish
script when you're done to restore the AP configuration. Please
read the upgrade directions in the Sun Enterprise Server Alternate
Pathing 2.3 Installation and Release Notes for specific details.
```

This script saves the current AP configuration information in the file `/var/tmp/apstate`. You may examine the `/var/tmp/apstate` file if you wish, but do not modify or remove it. Doing so can compromise the upgrade procedure.

- b. **Remove the packages** `SUNWapdoc`, `SUNWaprr`, `SUNWapu`, `SUNWabap` **and** `SUNWapdv` **(if applicable) by using the** `pkgrm(1M)` **command.**
- c. **If you are *not* upgrading your Solaris operating environment, reboot before proceeding to Step 6.**
4. **Upgrade the Solaris operating environment (if applicable) now.**

---

**Note** – You *must* upgrade the Solaris operating environment if you are running a version prior to Solaris 2.6.

---



---

**Caution** – Make sure you upgrade the correct slice. If you were previously using a volume manager to mirror the boot disk, and if you were also using AP to alternately path each boot disk mirror, then there are four physical paths that were previously potential paths to the boot disk (two alternate paths for each boot disk mirror). Now that both AP and the volume manager have been deconfigured, examine `/etc/vfstab` to determine the physical path that corresponds to the `root (/)` file system. When you run `suninstall`, specify that path as the disk to upgrade. Later, when you restore your volume manager, be sure to designate that disk as the primary mirror. See your volume manager documentation for information on determining which physical slice is used when booting.

---

---

**Note** – When partitioning the hard drive during the Solaris software installation, you must dedicate an entire disk partition that has at least 300 Kbytes to each database copy. For more detailed information on partitioning for the AP databases, see Chapter 2, “Alternate Pathing Database” in the *Alternate Pathing 2.3.1 User Guide*.

---

See “Upgrading a System” in *Solaris 8 (SPARC Platform Edition) Installation Library*. Note that you must choose the upgrade option to perform an upgrade of the Solaris operating environment.



**5. When the Solaris software upgrade process is completely finished, install the correct `ssd` patch.**

---

**Note** – If you have *not* upgraded the Solaris operating environment or you did *not* reboot as part of the upgrade or Step 3, do so now.

---

AP 2.3.1 installation checks for the presence of an `ssd` patch. If the patch is not present then, depending on your configuration, the following message maybe displayed:

```
Alternate Pathing Subsystem Drivers
(sparc) 2.3.1,REV=2000.05.09.11.28
Copyright 2000 Sun Microsystems, Inc. All rights reserved.
## Executing checkinstall script.
Determining patch requirements...
Verifying required patches are installed...
Required patches not installed: 109524-01
###
### Patch verification failed.
### Alternate Pathing 2.3.1 requires this package.
### You MUST apply the required patches before
### proceeding.
###
### PACKAGE INSTALLATION FAILED.
###
checkinstall script suspends

Installation of <SUNWapdv> was suspended (administration).
No changes were made to the system.
```

See Section “`ssd` Patch” on page 110 for the required patches if you have not already done so.

---

**Note** – For information on this patch, see Section “Fixed Other Bugs” on page 35 (Sun BugID 4295457).

---

**6. Upgrade to AP 2.3.1**

**a. Log in as superuser and type:**

- If you downloaded software from the web:

```
# cd /download_directory/ap_2_3_1_sparc/Tools
```

- If you are installing the upgrade from the CD-ROM:

```
# cd /cdrom/cdrom0/Alternate_Pathing_2.3.1/Tools
```

- b. Install the required AP 2.3.1 packages:**

```
# pkgadd -d . SUNWapdoc SUNWapdv SUNWapr SUNWapu
```

---

**Note** – You can install the packages in any order you wish but you must install them all. Package installation depends on the `ssd(7D)` patch being present. See “`ssd Patch`” on page 110 for more information.

---

- c. Run the following script to restore the original AP configuration:**

---

**Note** – Be sure to read “Simultaneously Upgrading AP and Solaris Software” on page 124 before performing the following command.

---

```
# /path/Alternate_Pathing_2.3.1.1/Tools/ap_upgrade_finish
...
ap_upgrade_finish complete. (State saved in /var/tmp/apstate.) Now
you can upgrade and configure any volume managers or other software
to use AP metadevices. Please read the upgrade directions in the
Sun Enterprise Server Alternate Pathing 2.3 Installation and
Release Notes for specific details.
```

- d. Reboot.**

- 7. If you have a third party volume manager, install and configure it according to manufacturer’s instructions now.**

---

**Note** – If your boot disk is mirrored, make sure you specify the upgraded disk as the primary mirror.

---

Upgrade is now complete.

---

# OpenBoot Emergency Procedures

---

The introduction of USB keyboards with the newest Sun desktop systems has made it necessary to change some of the OpenBoot™ emergency procedures. Specifically, the Stop-N, Stop-D, and Stop-F commands that are available on systems with standard (non-USB) keyboards are not supported on systems that have USB keyboards. The following sections describe the OpenBoot emergency procedures for systems with standard keyboards and for newer systems with USB keyboards.

---

## OpenBoot Emergency Procedures for Systems with Standard (non-USB) Keyboards

When issuing any of these commands, press the keys immediately after turning on the power to your system, and hold the keys down for a few seconds until the keyboard LEDs flash.

---

Command	Description
Stop	Bypass POST. This command does not depend on security mode. (Note: Some systems bypass POST as a default. In such cases, use Stop-D to start POST).
Stop-A	Abort.
Stop-D	Enter the diagnostic mode (set <code>diag-switch?</code> to true).
Stop-F	Enter Forth on TTYA instead of probing. Use <code>fexit</code> to continue with the initialization sequence. Useful if hardware is broken.
Stop-N	Reset NVRAM contents to default values.

---

---

# OpenBoot Emergency Procedures for Systems with USB Keyboards

The following paragraphs describe how to perform the functions of the Stop commands on systems that have USB keyboards.

## Stop-A

Stop-A (Abort) works the same as it does on systems with standard keyboards, except that it does not work during the first few seconds after the machine is reset.

## Stop-N Equivalent

- 1. After turning on the power to your system, wait until the front panel power button LED begins to blink and you hear an audible beep.**
- 2. Quickly press the front panel power button twice (similar to the way you would double-click a mouse).**

A screen similar to the following is displayed to indicate that you have successfully reset the NVRAM contents to the default values:

```
Sun Blade 1000 (2 X UltraSPARC-III) , Keyboard Present
```

```
OpenBoot 4.0, 256 MB memory installed, Serial #12134241.
```

```
Ethernet address 8:0:20:b9:27:61, Host ID: 80b92761.
```

```
Safe NVRAM mode, the following nvram configuration variables have  
been overridden:
```

```
'diag-switch?' is true
```

```
'use-nvramrc?' is false

'input-device', 'output-device' are defaulted

'ttya-mode', 'ttyb-mode' are defaulted
```

```
These changes are temporary and the original values will be
restored
```

```
after the next hardware or software reset.
```

```
ok
```

Note that some NVRAM configuration parameters are reset to their defaults. They include parameters that are more likely to cause problems, such as TTYA settings. These NVRAM settings are only reset to the defaults for this power cycle. If you do nothing other than reset the machine at this point, the values are not permanently changed. Only settings that you change manually at this point become permanent. All other customized NVRAM settings are retained.

Typing `set-defaults` discards any customized NVRAM values and permanently restores the default settings for all NVRAM configuration parameters.

---

**Note** – Once the power button LED stops blinking and stays lit, pressing the power button again will power off the system.

---

## Stop-F Functionality

The Stop-F functionality is not available in systems with USB keyboards.

## Stop-D Functionality

The Stop-D (diags) key sequence is not supported on systems with USB keyboards, however, the Stop-D functionality can be closely emulated by using the power button double-tap (see Stop-N Functionality), since this temporarily sets `diag-switch?` to `true`. If you want the diagnostic mode turned on permanently, type:

```
ok setenv diag-switch? true
```

# Sun Fire 6800/4810/4800/3800 Systems Solaris Operating Environment Commands

---

This chapter describes the Solaris operating environment specific information for this family of mid-range systems:

- Sun Fire 6800 system
- Sun Fire 4810 system
- Sun Fire 4800 system
- Sun Fire 3800 system

---

## Installing, Booting, and Halting the Solaris Operating Environment

When you turn power on to the system, the system controller application powers on. After system controller power on, you can type system controller commands.

### ▼ To Install and Boot the Solaris Operating Environment for the First Time

#### **1. Install the Solaris Operating Environment.**

Refer to your Solaris installation guide, which is available online with your version of the Solaris Operating Environment.

**2. Enter the system controller domain shell you want to power on.**

Refer to Chapter 2, “System Controller Navigation Procedures” in the *Sun Fire 6800/4810/4800/3810 Systems Platform Administration Manual*, which is shipped with your system.

**3. Power on and boot the domain.**

Refer to Chapter 2, “System Controller Navigation Procedures” in the *Sun Fire 6800/4810/4800/3810 Systems Platform Administration Manual*, which is shipped with your system.

## ▼ To Halt the Solaris Operating Environment

**1. Enter the system controller domain console for the domain you want to halt.**

Refer to the chapter “System Controller Navigation” or to the chapter “Maintenance” in the *Sun Fire 6800/4810/4800/3810 Systems Platform Administration Manual*, which is shipped with your system.

**2. From the domain console, as root, halt the Solaris Operating Environment for each domain, by typing `init 0`.**

```
root# init 0
ok
```



---

# Solaris Operating Environment Software

## IP Multipathing (IPMP) Software

The Solaris operating environment implementation of IPMP provides the following features (TABLE 10-1).

TABLE 10-1 IPMP Features

Feature	Description
Failure detection	Ability to detect when a network adaptor has failed and automatically switches over network access to an alternate network adaptor. This assumes that you have configured an alternate network adapter.
Repair detection	Ability to detect when a network adaptor that failed previously has been repaired and automatically switches back (failback) the network access from an alternate network adaptor. This assumes that you have enabled failbacks.
Outbound load spreading	Outbound network packets are spread across multiple network adaptors without affecting the ordering of packets in order to achieve higher throughput. Load spreading occurs only when the network traffic is flowing to multiple destinations using multiple connections.

The IP Network Multipathing (IPMP) software provides three important features:

- If your system is configured with an alternate network adapter, then it can failover from one network path to another.
- It can also failback to the original network adapter, after it is repaired.
- The IP Network Multipathing software also spreads out the outbound network load between the two network adapters to achieve higher throughput. Load spreading only occurs when the outbound network traffic is flowing to multiple destinations using multiple connections.

For more information on IP Network Multipathing (IPMP), refer to the *IP Network Multipathing Administration Guide*, which is available online with your Solaris operating environment release.

---

# Sun Management Center 3.0 Platform Update 1 Software

The Sun Management Center 3.0 Platform Update 1 software is the graphical user interface for managing these mid-range systems.

To optimize the effectiveness of the Sun Management Center 3.0 Platform Update 1 software, you must install it on a separate system. The Sun Management Center 3.0 Platform Update 1 software has the capability to logically group domains and the system controller into a single manageable object, to simplify operations.

The Sun Management Center 3.0 Platform Update 1 software, once configured, is also the recipient of SNMP traps and events.

To use the Sun Management Center 3.0 Platform Update 1 software, you must attach the System Controller board to a network. With a network connection, you can view both the command line interface and the graphical user interface. To attach the System Controller board Ethernet port, refer to the installation documentation that was shipped with your system.

For instructions on how to use the Sun Management Center 3.0 Platform Update 1 software, refer to the *Sun Management Center 3.0 Software Supplement for Sun Fire 6800/4810/4800/3800 Systems*, which is available online.

---

## Reliability, Availability and Serviceability (RAS)

Reliability, availability, and serviceability (RAS) are features of these mid-range systems. The descriptions of these features are:

- *Reliability* can be defined as the probability that a system stays operational for a specified time period when operating under normal environmental conditions. Reliability differs from availability in that reliability only involves system failure, whereas availability depends on both failure and recovery.
- *Availability* is the percentage of time that a system is available to perform its functions correctly, also known as average availability. Availability may be measured at the platform level or in the context of the availability of a service to an end-client. The platform availability is likely to impose an upper limit on the availability of any products built on top of that platform.

- *Serviceability* measures the ease and effectiveness of maintenance and system repair for the product. There is no single well-defined metric, as serviceability may include both Mean Time to Repair (MTTR) and diagnosability.

The following section describes nomenclature serviceability information, which is specific to these mid-range servers. For more information on these RAS features that involve the Solaris operating environment, refer to the Solaris online documentation that is available with your Solaris operating environment release or the “Overview” chapter of the *Sun Fire 6800/4810/4800/3810 Systems Platform Administration Manual*, which is available both hardcopy and online with your system.

## Nomenclature Serviceability Feature

The system controller, the Solaris operating environment, power-on self-test (POST), and the OpenBoot PROM error messages use field replaceable unit (FRU) name identifiers that match the physical labels in the system. The only exception is the OpenBoot PROM nomenclature used for I/O devices.

For more information on these RAS features that involve the Solaris operating environment, refer to the Solaris online documentation that is available with your Solaris operating environment release or the “Overview” chapter of the *Sun Fire 6800/4810/4800/3810 Systems Platform Administration Manual*, which is available both hardcopy and online with your system.

---

## syslog Loghost

For information on how to set up the `syslog` loghost using the system controller software, refer to the chapter “System Power On and Setup” of the *Sun Fire 6800/4810/4800/3810 Systems Platform Administration Manual*. This is part of the system controller `setupplatform` system controller command, which is run when you setup the platform.

For more details on the `setupplatform` command, refer to the `setupplatform` command in the *Sun Fire 6800/4810/4800/3800 System Controller Command Reference Manual* and to the chapter “System Power On and Setup” in the *Sun Fire 6800/4810/4800/3810 Systems Platform Administration Manual*. Both of these books are available both hard copy and online with your system.

---

# Displaying System Configuration Information

To display system configuration parameters, use the following Solaris operating environment commands:

- `prtconf` command
- `prtdiag` command
- `sysdef` command
- `format` command

## `prtconf` Command

The Solaris operating environment `prtconf` command prints the system configuration information. The output includes:

- Total amount of memory
- Configuration of the system peripherals formatted as a device tree

This command has many options. For the command syntax, options, and examples, see the `prtconf` man page.

## `prtdiag` Command

The Solaris operating environment `prtdiag (1M)` command displays the following information to the domain of your system:

- Configuration
- Diagnostics
- Temperature
- Sensor

For command syntax, options, and examples, see the `prtdiag(1M)` man page.

## `sysdef` Command

The Solaris operating environment `sysdef` utility outputs the current system definition in tabular form. It lists:

- All hardware devices
- Pseudo devices
- System devices
- Loadable modules
- Values of selected kernel tunable parameters

This command generates the output by analyzing the named bootable operating system file (*namelist*) and extracting configuration information from it. The default system *namelist* is `/dev/kmem`.

For command syntax, options, and examples, see the `sysdef` man page.

## format Command

The Solaris operating environment utility, `format`, which is used to format drives, can also be used to display both logical and physical device names. For command syntax, options, and examples see the `format` man page.



# Localized Packages on the Supplement CD

## Japanese Localized Packages

**TABLE A-1** Japanese Localized Packages

Software Product	Package Name	Description
SunForum	SUNWjadat	Japanese (ja-EUC) SunForum
	SUNWjpdatt	Japanese (ja-PCK) SunForum
Alternate Pathing	SUNWjaap	Japanese localization for Alternate Pathing
	SUNWjabap	Japanese AnswerBook for Alternate Pathing
	SUNWjeapd	Japanese manual pages for Alternate Pathing
	SUNWjpapd	Japanese (PCK) manual pages for Alternate Pathing
	SUNWjuapd	Japanese (UTF-8) manual pages for Alternate Pathing
Remote System Control	SUNWjersc	Japanese (EUC) Remote System Control
	SUNWjrscd	Japanese (EUC) Remote System Control User Guide
	SUNWjrscj	Japanese (EUC) Remote System Control GUI

**TABLE A-1** Japanese Localized Packages (*Continued*)

<b>Software Product</b>	<b>Package Name</b>	<b>Description</b>	
ShowMe TV	SUNWjasmt	ShowMe TV Japanese (ja-EUC) localization files	
	SUNWjpsmt	ShowMe TV Japanese (ja-PCK) localization files	
	SUNWjusmt	ShowMe TV Japanese (ja-UTF8) localization files	
PC launcher	SUNWjdpcv	Japanese (Common) PC launcher help	
	SUNWjepcp	Japanese (EUC) PC launcher message	
	SUNWjppcp	Japanese (PCK) PC launcher message	
	SUNWjupcp	Japanese (UTF-8) PC launcher message	
PC file viewer	SUNWjepcv	Japanese (EUC) PC File Format Viewer	
	SUNWjepcz	Japanese (EUC) PC File Formats support in CDE	
	SUNWjppcv	Japanese (PCK) PC File Format Viewer	
	SUNWjppcz	Japanese (PCK) PC File Formats support in CDE	
	SUNWjupcv	Japanese (UTF-8) PC File Format Viewer	
	SUNWjupcz	Japanese (UTF-8) PC File Formats support in CDE	
	Sun Gigabit Ethernet Adapter Driver	SUNWjegem	Japanese (EUC) Sun Gigabit Ethernet Adapter Driver Man Pages
		SUNWjpgem	Japanese (PCK) Sun Gigabit Ethernet Adapter Driver Man Pages
SUNWjugem		Japanese (UTF-8) Sun Gigabit Ethernet Adapter Driver Man Pages	
SunFDDI	SUNWjenfm	Japanese (EUC) SunFDDI SBus Man Pages	
	SUNWjepfm	Japanese (EUC) SunFDDI PCI Man Pages	
	SUNWjpnfm	Japanese (PCK) SunFDDI SBus Man Pages	
	SUNWjppfm	Japanese (PCK) SunFDDI PCI Man Pages	
	SUNWjunfm	Japanese (UTF-8) SunFDDI SBus Man Pages	



**TABLE A-1** Japanese Localized Packages (*Continued*)

Software Product	Package Name	Description
	SUNWjupfm	Japanese (UTF-8) SunFDDI PCI Man Pages
SunVTS	SUNWjpvtn	Japanese (PCK) SunVTS Man Pages
	SUNWjuvtn	Japanese (UTF-8) SunVTS Man Pages
	SUNWjvtsm	Japanese (EUC) SunVTS Man Pages
AnswerBook	SUNWahwja	Solaris 8 on Sun Hardware Collection - Japanese
Capacity on Demand	SUNWjcodb	Japanese AnswerBook for Capacity on Demand
Sun Enterprise 10000 SSP	SUNWjassp	Japanese AnswerBook for Sun Enterprise 10000 SSP
CDRW	SUNWjcdrw	Japanese (EUC) Manual Page and Message for CDRW
Netra ct	SUNWjecte	Japanese (EUC) manual pages and messages for Netra ct Platform Software

## German Localized Packages

**TABLE A-2** German Localized Packages

Software Product	Package Name	Description
SunForum	SUNWdedat	German SunForum
PC launcher	SUNWdepcp	PC launcher German messages
PC file viewer	SUNWdepcv	PC File Viewer German messages
	SUNWdepcz	PC File Viewer German help and icons
Remote System Control	SUNWdersc	German Remote System Control
	SUNWdrscd	German Remote System Control User Guide
	SUNWdrscj	German Remote System Control GUI
ShowMe TV	SUNWdesmt	ShowMe TV German localization files

**TABLE A-2** German Localized Packages

Software Product	Package Name	Description
AnswerBook	SUNWAhwde	Solaris 8 on Sun Hardware Collection - German
Netra ct	SUNWdecte	German (EUC) localization for Netra ct
CDRW	SUNWdcdrw	German (EUC) localization for CDRW utility

## Italian Localized Packages

**TABLE A-3** Italian Localized Packages

Software Product	Package Name	Description
SunForum	SUNWitdat	Italian SunForum
PC launcher	SUNWitpcp	PC launcher Italian messages
PC file viewer	SUNWitpcv	PC File Viewer Italian messages
	SUNWitpcz	PC File Viewer Italian help and icons
Remote System Control	SUNWitrsc	Italian Remote System Control
	SUNWirscd	Italian Remote System Control User Guide
	SUNWirscj	Italian Remote System Control GUI
ShowMe TV	SUNWitsmt	ShowMe TV Italian localization files
AnswerBook	SUNWAhwit	Solaris 8 on Sun Hardware Collection - Italian
Netra ct	SUNWitcte	Italian (EUC) localization for Netra ct
CDRW	SUNWicdrw	Italian localization for CDRW utility

---

# French Localized Packages

**TABLE A-4** French Localized Packages

Software Product	Package Name	Description
SunForum	SUNWfrdat	French SunForum
PC launcher	SUNWfrpcp	PC launcher French messages
PC file viewer	SUNWfrpcv	PC File Viewer French messages
	SUNWfrpcz	PC File Viewer French help and icons
Remote System Control	SUNWfrsc	French Remote System Control
	SUNWfrscd	French Remote System Control User Guide
	SUNWfrscj	French Remote System Control GUI
ShowMe TV	SUNWfrsmt	ShowMe TV French localization files
AnswerBook	SUNWAhwfr	Solaris 8 on Sun Hardware Collection - French
Netra ct	SUNWfrcte	French (EUC) localization for Netra ct
CDRW	SUNWfcdrw	French localization for CDRW utility
Alternate Pathing	SUNWfabap	French Alternate Pathing collection

---

# Spanish Localized Packages

**TABLE A-5** Spanish Localized Packages

Software Product	Package Name	Description
SunForum	SUNWesdat	Spanish SunForum
PC launcher	SUNWespcp	PC launcher Spanish messages
PC file viewer	SUNWespcv	PC File Viewer Spanish messages
	SUNWespcz	PC File Viewer Spanish help and icons
Remote System Control	SUNWesrsc	Spanish Remote System Control
	SUNWerscd	Spanish Remote System Control User Guide

**TABLE A-5** Spanish Localized Packages *(Continued)*

Software Product	Package Name	Description
	SUNWerscj	Spanish Remote System Control GUI
ShowMe TV	SUNWessmt	ShowMe TV Spanish localization files
AnswerBook	SUNWAhwes	Solaris 8 on Sun Hardware Collection - Spanish
Netra ct	SUNWescte	Spanish (EUC) localization for Netra ct
CDRW	SUNWecdrw	Spanish localization for CDRW utility

## Swedish Localized Packages

**TABLE A-6** Swedish Localized Packages

Software Product	Package Name	Description
SunForum	SUNWsvdat	Swedish SunForum
PC launcher	SUNWsvpcp	PC launcher Swedish messages
PC file viewer	SUNWsvpcv	PC File Viewer Swedish messages
	SUNWsvpcz	PC File Viewer Swedish help and icons
Remote System Control	SUNWsvrsc	Swedish Remote System Control
	SUNWsrscd	Swedish Remote System Control User Guide
	SUNWsrscj	Swedish Remote System Control GUI
ShowMe TV	SUNWsvsmt	ShowMe TV Swedish localization files
AnswerBook	SUNWAhwsv	Solaris 8 on Sun Hardware Collection - Swedish
Netra ct	SUNWsvcte	Swedish (EUC) localization for Netra ct
CDRW	SUNWscdrw	Swedish localization for CDRW utility

# Traditional Chinese Localized Packages

**TABLE A-7** Traditional Chinese Localized Packages

Software Product	Package Name	Description
SunForum	SUNW5dat	Traditional Chinese (zh_TW-BIG5) SunForum
	SUNWhdat	Traditional Chinese (zh_TW-EUC) SunForum
PC launcher	SUNW5pcp	PC launcher Traditional Chinese (zh_TW-BIG5) messages
	SUNWhcpcp	PC launcher Traditional Chinese (common) messages
	SUNWhdpcp	PC launcher Traditional Chinese (zh_TW-EUC) messages
PC file viewer	SUNW5pcv	PC File Viewer Traditional Chinese (zh_TW-BIG5) messages
	SUNW5pcz	PC File Viewer Traditional Chinese (zh_TW-BIG5) help and icons
	SUNWhcpv	PC File Viewer Traditional Chinese (common) messages
	SUNWhdpcv	PC File Viewer Traditional Chinese (zh_TW-EUC) messages
	SUNWhdpcz	PC File Viewer Traditional Chinese (zh_TW-EUC) help and icons
Remote System Control	SUNWhrsc	Traditional Chinese (EUC) Remote System Control
	SUNWhrscd	Traditional Chinese (EUC) Remote System Control User Guide
	SUNWhrscj	Traditional Chinese (EUC) Remote System Control GUI
ShowMe TV	SUNW5smt	ShowMe TV Traditional Chinese (zh_TW-Big5) localization files
	SUNWhsmt	Traditional Chinese (zh_TW-EUC) localization files for ShowMe TV
Netra ct	SUNWhcte	Traditional Chinese (EUC) localization for Netra ct
CDRW	SUNWhcdrw	Traditional Chinese (EUC) localization for CDRW utility

# Simplified Chinese Localized Packages

**TABLE A-8** Simplified Chinese Localized Packages

Software Products	Package Name	Description
SunForum	SUNWcdat	Simplified Chinese (zh-EUC) SunForum
PC launcher	SUNWccpcp	PC launcher SimplifiedChinese (common) messages
	SUNWcdpcp	PC launcher SimplifiedChinese (zh-EUC) messages
	SUNWgpcp	PC launcher SimplifiedChinese (zh-GBK) messages
PC file viewer	SUNWccpcv	PC file viewer Simplified Chinese (common) messages
	SUNWcdpcv	PC file viewer Simplified Chinese (zh-EUC) messages
	SUNWcdpcz	PC file viewer Simplified Chinese (zh-EUC) help and icons
	SUNWgpcv	PC file viewer Simplified Chinese (zh-GBK) messages
	SUNWgpcz	PC file viewer Simplified Chinese (zh-GBK) help and icons
Remote System Control	SUNWcrsc	Simplified Chinese (EUC) Remote System Control
	SUNWcrscd	Simplified Chinese (EUC) Remote System Control User Guide
	SUNWcrscj	Simplified Chinese (EUC) Remote System Control GUI
ShowMe TV	SUNWcsmt	ShowMe TV Simplified Chinese (zh-EUC) localization files
	SUNWgsmt	ShowMe TV Simplified Chinese (zh-GBK) localization files
Netra ct	SUNWccte	Simplified Chinese (EUC) localization for Netra ct
CDRW	SUNWccdrw	Simplified Chinese (EUC) localization for CDRW utility

---

# Korean Localized Packages

**TABLE A-9** Korean Localized Packages

Software Product	Package Name	Description
SunForum	SUNWkodat	Korean SunForum
PC launcher	SUNWkcpcp	PC launcher Korean (common) messages
	SUNWkdpcp	PC launcher Korean (ko) messages
	SUNWkupcp	PC launcher Korean (ko.UTF-8) messages
PC file viewer	SUNWkcpcv	PC file viewer Korean (common) messages
	SUNWkdpcv	PC file viewer Korean (ko) messages
	SUNWkdpcz	PC file viewer Korean (ko) help and icons
	SUNWkupcv	PC file viewer Korean (ko.UTF-8) messages
	SUNWkupcz	PC file viewer Korean (ko.UTF-8) help and icons
Remote System Control	SUNWkrsc	Korean (EUC) Remote System Control
	SUNWkrscd	Korean (EUC) Remote System Control User Guide
	SUNWkrscj	Korean (EUC) Remote System Control GUI
ShowMe TV	SUNWkosmt	ShowMe TV Korean (ko-EUC) localization files
	SUNWkusmt	ShowMe TV Korean (ko-UTF-8) localization files
Netra ct	SUNWkocte	Korean (EUC) localization for Netra ct
CDRW	SUNWkcdrw	Korean (EUC) localization for CDRW utility





# Index

---

## A

- AnswerBook, 47
  - hardware
  - manuals, 47
  - Updates CD
    - installation, xii
- AnswerBook2
  - installing the SSP document collection, 120
  - server software, 120
- AutoShutdown
  - availability, 103
- AutoWakeup
  - availability, 103

## C

- Chinese packages
  - Simplified Chinese, 150
  - Traditional Chinese, 149
- custom profiles
  - JumpStart, 10

## D

- database
  - database size, recommended, 105, 123, 128
- default Power Management settings, 103
- device Power Management availability, 103
- display Power Management availability, 103

## E

- Energy Star Computers program, 101

## F

- flash PROM
  - reprogramming, 73
- flash PROM jumper settings
  - Sun Enterprise 450 system, 73
  - Ultra 1 system, 60
  - Ultra 2 system, 61
- flash PROM P0601 jumper
  - Ultra Enterprise 3000-6000 systems, 94
- flash PROM upgrade
  - cautions, 63, 84
  - determining, 56, 79
  - overview, 57, 81
  - step-by-step procedure, 58, 82
- French packages, 147
- fresh install
  - from CD-ROM, 106

## G

- German packages, 145

## I

- install
  - from CD-ROM, 106

installation  
Solaris CD, xii  
Web Start process, 110  
Italian packages, 146

## J

Japanese packages, 143  
Java 3D, 44  
jumper  
write enabled setting, 59, 74, 83  
jumpers  
flash PROM, 59, 73  
JumpStart  
Creator graphics accelerator entry, 11  
custom profiles, 10  
S24 frame buffer entry, 11  
SPARCstation 10SX entry, 11  
SPARCstation 20 entry, 11  
SunSwift SBus adapter entry, 11  
SX frame buffer entry, 11

## K

keyswitch  
diagnostics mode, 62, 83  
power-on mode, 62, 83  
Korean packages, 151

## L

latest news  
where to find information, xii

## M

monitors, configuring, 48

## N

new products  
where to find information, xii  
news

latest  
where to find information, xii

## O

OpenGL, 25

## P

PC file viewer, 37  
PC launcher, 30  
peripherals  
where to find information, xii  
pkgadd, 20  
installing update software, 20  
power interruption recovery procedure, 67, 96  
products  
new  
where to find information, xii

## R

recovery procedure  
power interruption, 67, 96  
Remote System Control, 42  
reprogramming, flash PROM, 58, 82

## S

S24 frame buffer  
interactive installation  
required software cluster, 4  
manual installation  
required software packages, 8  
ShowMe TV, 39  
Solaris 2.5  
interactive installation, 4  
Solaris 7 operating environment  
installing, 59, 83  
Solaris Webstart 2.0, 18  
Spanish packages, 147  
SPARC architectures, 103  
SPARCstation 10SX

- interactive installation
    - required software cluster, 5
- SPARCstation 20
  - interactive installation
    - required software cluster, 5
  - platform notes, 49
- SPARCstation 4
  - interactive installation
    - required software cluster, 5
- SPARCstation 5
  - interactive installation
    - required software cluster, 5
- SPARCstorage Array
  - interactive installation
    - required software cluster, 5
  - manual installation
    - required software packages, 9
- SSP
  - installation, 110
- Sun Enterprise 450 system
  - flash PROM jumper settings, 73
- sun4u UltraSPARC III (Energy Star, v3), 103
- SunATM, 43
- SunFDDI PCI Driver, 43
- SunFDDI SBus Driver, 43
- SunForum, 42
- SunHSI PCI Driver, 43
- SunHSI SBus Driver, 43
- SunSwift SBus adapter
  - manual installation
    - required software packages, 8
- SunVTS, 23
- Swedish packages, 148
- SX frame buffer
  - interactive installation
    - required software cluster, 4
  - manual installation
    - required software packages, 8
- system
  - architecture
    - determining, 2
- system architecture distinctions, 103
  - sun4m, 103
  - sun4u (pre Energy Star 3.0), 103
  - sun4u (pre Energy Star, v3), 103

## U

- U.S. Environmental Protection Agency, 101
- Ultra 1 Creator Model 170E
  - interactive installation
    - required software cluster, 6
  - manual installation
    - required software packages, 9
- Ultra 1 Creator3D Model 170E
  - interactive installation
    - required software cluster, 6
  - manual installation
    - required software packages, 9
- Ultra 1 Model 140
  - interactive installation
    - required software package, 5
- Ultra 1 Model 170
  - interactive installation
    - required software package, 5
- Ultra Enterprise 10000
  - manual installation
    - required software package, 9
- Updates CD
  - contents, 48, 51
  - installation, xii
  - installing
    - pkgadd, 20
- upgrade
  - from CD-ROM, 106
- upgrade, flash PROM
  - performing, 58, 82

## V

- validation test suite, 23

## W

- Web Start, 110
- write enable jumper
  - setting, 59, 73
- write enabling the system, 59, 83
  - servers, 62

