



# Sun StorEdge™ N8600 Filer Release Notes

---

Sun Microsystems, Inc.  
901 San Antonio Road  
Palo Alto, CA 94303  
U.S.A. 650-960-1300

Part No. 806-6892-10  
February 2001, [Revision A](#)

[Send comments about this document to: docfeedback@sun.com](mailto:docfeedback@sun.com)

Copyright 2001 Sun Microsystems, Inc., 901 San Antonio Road • Palo Alto, CA 94303-4900 USA. All rights reserved.

This product or document is protected by copyright and distributed under licenses restricting its use, copying, distribution, and decompilation. No part of this product or document may be reproduced in any form by any means without prior written authorization of Sun and its licensors, if any. Third-party software, including font technology, is copyrighted and licensed from Sun suppliers.

Parts of the product may be derived from Berkeley BSD systems, licensed from the University of California. Microsoft Windows NT is a registered trademarks in the U.S. and other countries. UNIX is a registered trademarks in the U.S. and other countries, exclusively licensed through X/Open Company, Ltd. For Netscape Communicator™, the following notice applies: Copyright 1995 Netscape Communications Corporation. All rights reserved.

Sun, Sun Microsystems, the Sun logo, AnswerBook2, docs.sun.com, and Solaris are trademarks, registered trademarks, or service marks of Sun Microsystems, Inc. in the U.S. and other countries. All SPARC trademarks are used under license and are trademarks or registered trademarks of SPARC International, Inc. in the U.S. and other countries. Products bearing SPARC trademarks are based upon an architecture developed by Sun Microsystems, Inc.

The OPEN LOOK and Sun™ Graphical User Interface was developed by Sun Microsystems, Inc. for its users and licensees. Sun acknowledges the pioneering efforts of Xerox in researching and developing the concept of visual or graphical user interfaces for the computer industry. Sun holds a non-exclusive license from Xerox to the Xerox Graphical User Interface, which license also covers Sun's licensees who implement OPEN LOOK GUIs and otherwise comply with Sun's written license agreements.

Federal Acquisitions: Commercial Software—Government Users Subject to Standard License Terms and Conditions.

**DOCUMENTATION IS PROVIDED "AS IS" AND ALL EXPRESS OR IMPLIED CONDITIONS, REPRESENTATIONS AND WARRANTIES, INCLUDING ANY IMPLIED WARRANTY OF MERCHANTABILITY, FITNESS FOR A PARTICULAR PURPOSE OR NON-INFRINGEMENT, ARE DISCLAIMED, EXCEPT TO THE EXTENT THAT SUCH DISCLAIMERS ARE HELD TO BE LEGALLY INVALID.**

Copyright 2001 Sun Microsystems, Inc., 901 San Antonio Road • Palo Alto, CA 94303-4900 Etats-Unis. Tous droits réservés.

Ce produit ou document est protégé par un copyright et distribué avec des licences qui en restreignent l'utilisation, la copie, la distribution, et la décompilation. Aucune partie de ce produit ou document ne peut être reproduite sous aucune forme, par quelque moyen que ce soit, sans l'autorisation préalable et écrite de Sun et de ses bailleurs de licence, s'il y en a. Le logiciel détenu par des tiers, et qui comprend la technologie relative aux polices de caractères, est protégé par un copyright et licencié par des fournisseurs de Sun.

Des parties de ce produit pourront être dérivées des systèmes Berkeley BSD licenciés par l'Université de Californie. Microsoft Windows NT est une marque déposée aux Etats-Unis et dans d'autres pays. UNIX est une marque déposée aux Etats-Unis et dans d'autres pays et licenciée exclusivement par X/Open Company, Ltd. La notice suivante est applicable à Netscape Communicator™: Copyright 1995 Netscape Communications Corporation. Tous droits réservés.

Sun, Sun Microsystems, the Sun logo, AnswerBook2, docs.sun.com, et Solaris sont des marques de fabrique ou des marques déposées, ou marques de service, de Sun Microsystems, Inc. aux Etats-Unis et dans d'autres pays. Toutes les marques SPARC sont utilisées sous licence et sont des marques de fabrique ou des marques déposées de SPARC International, Inc. aux Etats-Unis et dans d'autres pays. Les produits portant les marques SPARC sont basés sur une architecture développée par Sun Microsystems, Inc.

L'interface d'utilisation graphique OPEN LOOK et Sun™ a été développée par Sun Microsystems, Inc. pour ses utilisateurs et licenciés. Sun reconnaît les efforts de pionniers de Xerox pour la recherche et le développement du concept des interfaces d'utilisation visuelle ou graphique pour l'industrie de l'informatique. Sun détient une licence non exclusive de Xerox sur l'interface d'utilisation graphique Xerox, cette licence couvrant également les licenciés de Sun qui mettent en place l'interface d'utilisation graphique OPEN LOOK et qui en outre se conforment aux licences écrites de Sun.

**CETTE PUBLICATION EST FOURNIE "EN L'ETAT" ET AUCUNE GARANTIE, EXPRESSE OU IMPLICITE, N'EST ACCORDEE, Y COMPRIS DES GARANTIES CONCERNANT LA VALEUR MARCHANDE, L'APTITUDE DE LA PUBLICATION A REPONDRE A UNE UTILISATION PARTICULIERE, OU LE FAIT QU'ELLE NE SOIT PAS CONTREFAISANTE DE PRODUIT DE TIERS. CE DENI DE GARANTIE NE S'APPLIQUERAIT PAS, DANS LA MESURE OU IL SERAIT TENU JURIDIQUEMENT NUL ET NON AVENU.**



# Sun StorEdge N8600 Release Notes

---

This document contains important information about the Sun StorEdge N8600 Filer that was not available at the time the product documentation was published.

Review this document so that you are aware of issues or requirements that can impact the installation and operation of the Sun StorEdge N8600 Filer. This document supplements the information contained in the *Sun StorEdge N8600 Filer Installation, Configuration, and Service Guide* and the *Sun StorEdge N8400 and N8600 Filer Administrator's Guide*. This document is organized as follows:

- “Reference Documentation” on page 4
- “Accessing Sun Documentation Online” on page 4
- “Starting Up the System” on page 5
- “Sun StorEdge T3 Disk Tray Repair Note” on page 5
- “System Installation Notes” on page 7
  - “Configuring LAN Connectivity for the Sun StorEdge T3 Disk Trays” on page 7
  - “Configuring the Disk Trays for Monitoring” on page 13
- “Errata” on page 15
  - “Sun StorEdge Component Manager” on page 15
  - “netstat Command” on page 15

---

# Reference Documentation

Document Title	Part Number
<i>Sun StorEdge N8600 Filer Installation, Configuration, and Service Guide</i>	806-6889
<i>Sun StorEdge N8400 and N8600 Filer Administrator's Guide</i>	806-6905

---

---

## Accessing Sun Documentation Online

The [www.sun.com](http://www.sun.com)<sup>sm</sup> web site enables you to access Sun technical documentation on the Web.

- 1. Access Sun StorEdge N8600 Filer product documentation on your browser.**

<http://www.sun.com>

- 2. Select Products & Solutions.**
- 3. Under Hardware, select Documentation.**
- 4. Under Product Documentation, select Network Storage Solutions.**
- 5. Under Product Documentation, select Network-Attached Storage (NAS).**

---

# Starting Up the System

---

**Note** – The order in which the machines are powered on is very important.

---

**1. Power on the Sun StorEdge T3 Disk Trays and wait for them to fully boot.**

Wait eight minutes. If possible, verify that the flashing LEDs on the rear panel of the disk trays go steady to indicate they are ready.

**2. Power on the Sun Enterprise 4500 Server.**

When the server has booted, the system is ready. You will then be prompted to answer the configuration questions. Refer to the *Sun StorEdge N8600 Filer Installation, Configuration, and Service Guide*.

---

## Sun StorEdge T3 Disk Tray Repair Note

Upon removing a disk drive from a powered-on disk tray, you will have 30 minutes to install a new drive, or the disk tray will automatically power-off.

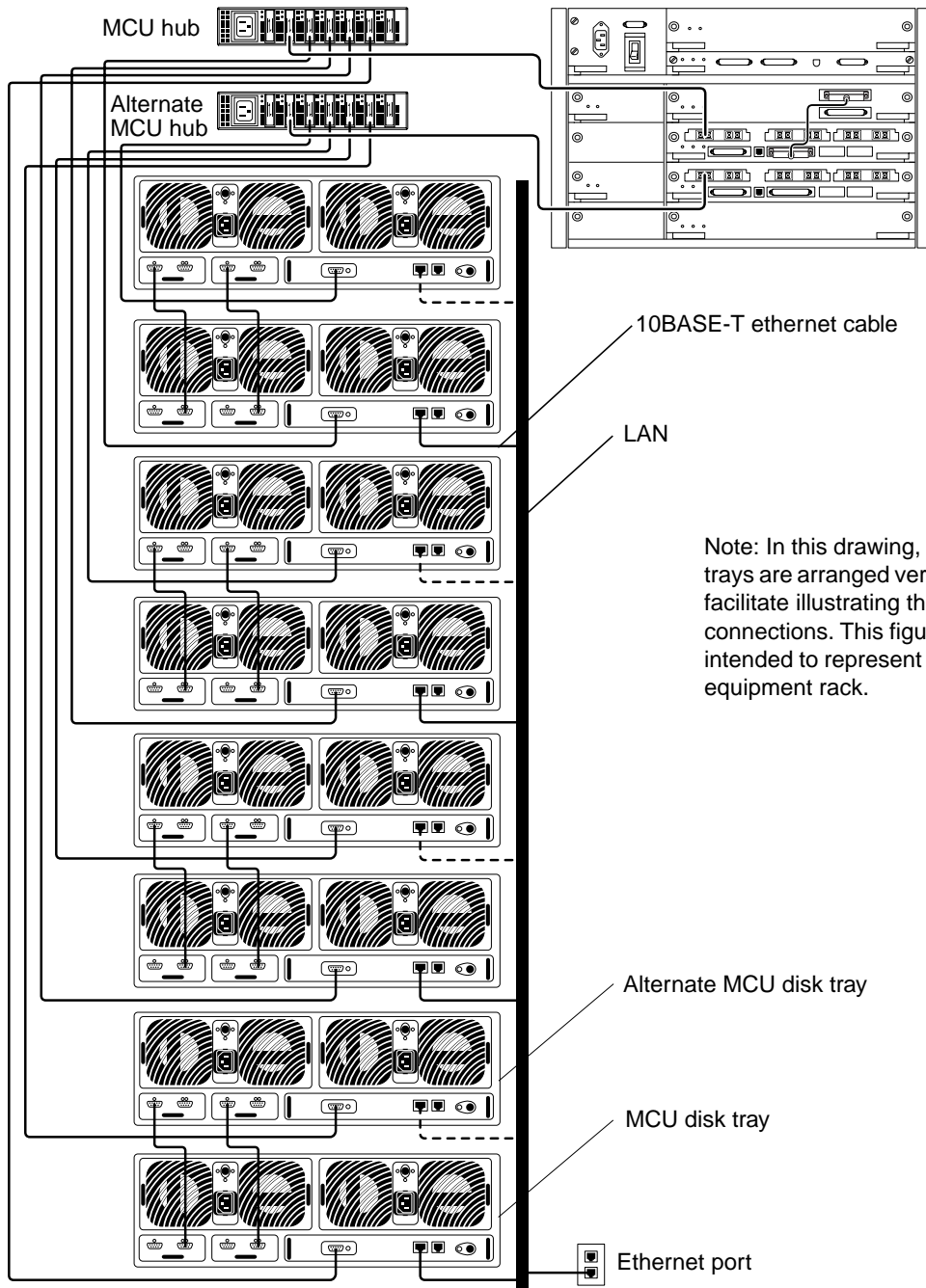

FIGURE 1 Minimum Configuration for the Sun StorEdge N8600 Filer

---

# System Installation Notes

## Configuring LAN Connectivity for the Sun StorEdge T3 Disk Trays

The Sun StorEdge T3 Disk Trays (hereafter referred to as “disk tray”) can be connected to a local area network (LAN) as shown in FIGURE 1. To set up the connectivity for a LAN, perform the following steps.

1. **Connect a terminal (monitor and keyboard) to the Console Port (see FIGURE 2) on the back of a Master Controller Unit (MCU) disk tray.**

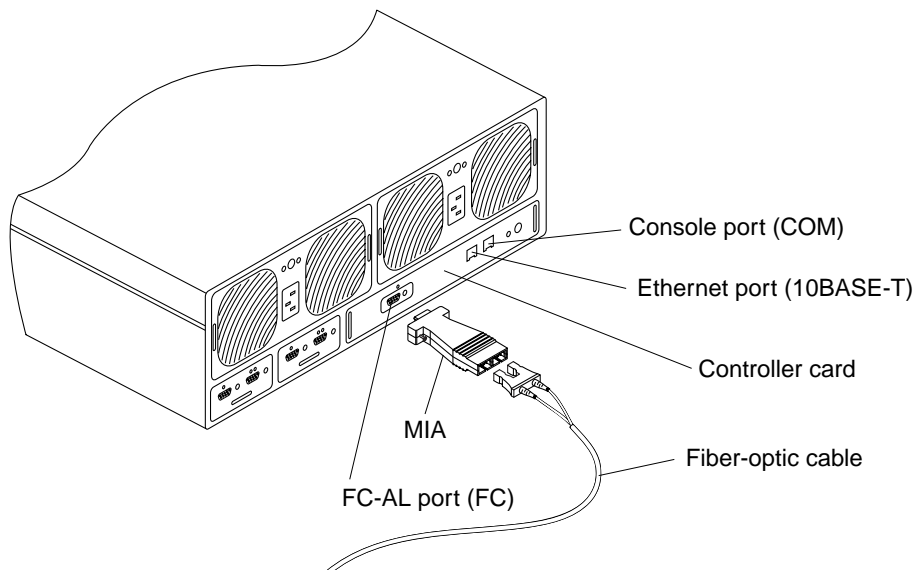
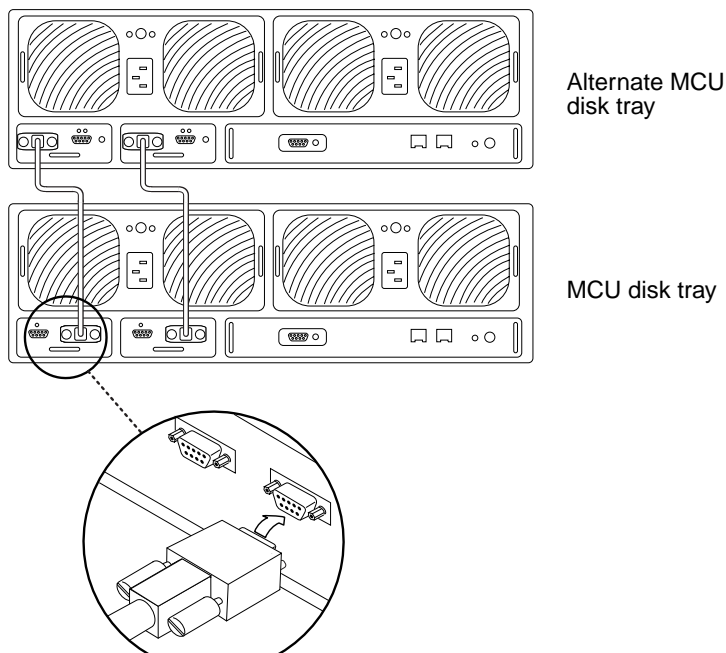

**FIGURE 2** Disk Tray Back Panel Details

---

**Note** – Disk trays are configured in partner groups consisting of a Master Controller Unit (MCU) disk tray and a Alternate MCU disk tray. The MCU is the bottom unit of the partner group as shown in FIGURE 3.

---



**FIGURE 3** Disk Tray Partner Group with MCU Disk Tray Located at the Bottom

If you use this connection, you can proceed to Step 2 on page 12. As an alternative you can connect to the MCU disk tray using either of the following methods:

## Tip Server

Connect to the disk tray Console Port with your tip server. From a separate workstation, open a telnet session to the tip server and select the corresponding port number that represents the disk tray. Proceed to Step 2 on page 12.

## Laptop Computer

Connect a standard telephone line with an RJ-3 connector to the disk tray Console Port. Attach the other end to the appropriate adapter and connect that to the serial port of your laptop PC. Set up a hyperterm connection by performing the following steps.

- a. **Choose: Start → Run.**

The Run dialog box is displayed.



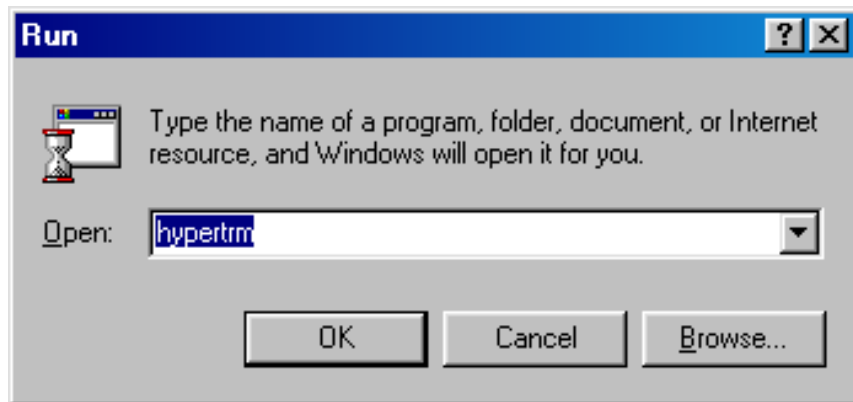

b. Type `hypertm`, and click **OK**.

The Connection Description dialog box is displayed.

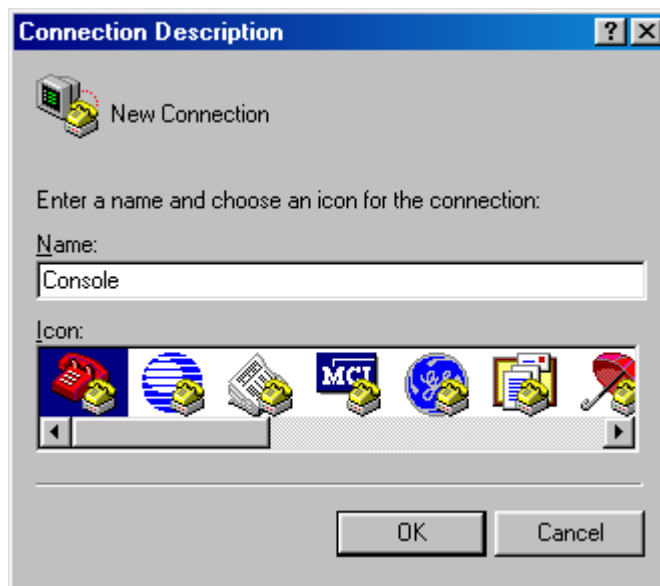

- c. Enter a connection name, choose a connection icon, and click OK.  
The Connect To dialog box is displayed.



- d. Choose the Com port that will be used to connect to the filer, and then click on OK.

The COM1 (or COM2) Properties dialog box is displayed.

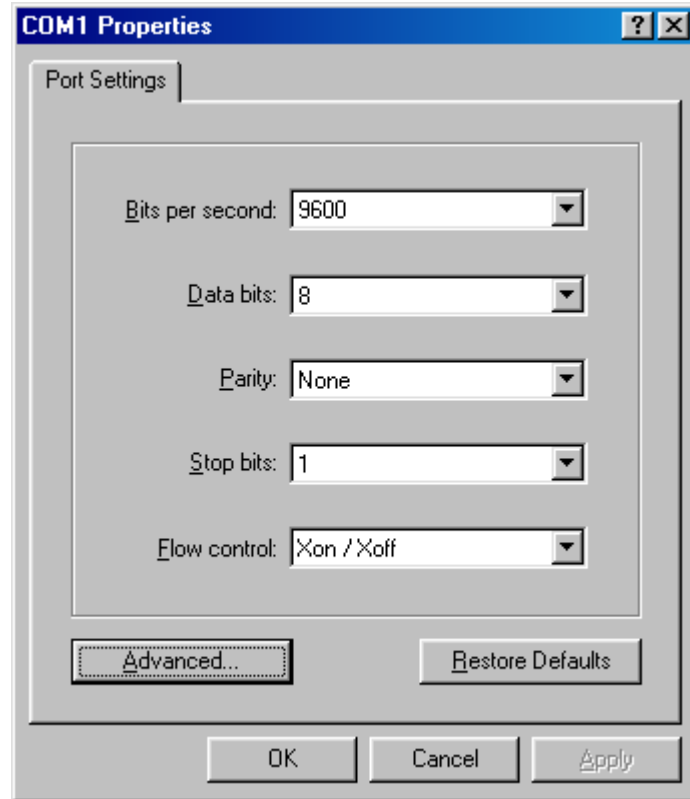

FIGURE 4 Microsoft Windows™ COM1 Properties Dialog Box

- e. Choose the exact parameters shown in FIGURE 4, and then click OK.

A new window is displayed.

- f. Press Enter to bring up the disk tray command-line interface (CLI), or the login dialogue box to access the disk tray CLI.

If the login dialogue box appears, enter the username and password.

**2. Set up the IP Address using the `set ip` command.**

This enables the basic ethernet connectivity to the disk trays. For example:

```
# t300name:/:<n> set ip 129.150.47.86
```

---

**Note** – <n> = the system-generated command count for each individual session.

---

**3. Set up the gateway address using the `set gateway` command.**

This enables you to access a disk tray outside of the subnet. For example:

```
# t300name:/:<n> set gateway 129.150.47.1
```

**4. Set the netmask using the `set netmask` command.**

The netmask specifies to network mask used to implement IP subnetting. For example:

```
# t300name:/:<n> set netmask 255.255.255.0
```

This establishes connectivity for the disk trays.

**5. Reboot the disk tray by typing the following:**

```
# t300name:/:<n> sync
# t300name:/:<n> reset
Reset the system, are you sure? [N]: Y
```

**6. Repeat steps 1 through 5 for every disk tray partner group (by connecting to the MCU disk tray).**

This completes the LAN configuration.

# Configuring the Disk Trays for Monitoring

1. Set up the LAN as described in “Configuring LAN Connectivity for the Sun StorEdge T3 Disk Trays” on page 7.
2. If necessary, access the disk tray’s command-line interface (CLI).
3. Establish the disk tray host name using the `set hostname` command.

```
# t300name:/:<n> set hostname hostname
```

---

**Note** – `<n>` = the system-generated command count for each individual session.

---

4. Disable the disk tray local/syslog and switch to SNMP by using the `set logto` command.

```
# t300name:/:<n> set logto *
```

5. To enable an ftp connection to the disk tray, set the root password using the `passwd` command.

```
# t300name:/:<n> passwd
# t300name:/:<n> [old] password
# t300name:/:<n> [new] password
# t300name:/:<n> [new] password
```

6. Use a text editor on the server to create a `syslog.conf` file in the `/tmp` directory that contains the following entry:

```
*.info    @hostname
```

where `hostname` specifies the name of the server.

---

**Note** – This allows Info, Notice, Warning, and Error messages to be passed from the disk tray to the server.

---

7. Use a text editor on the server to create a `hosts` file in the `/tmp` directory as follows:

```
# t300name:/:<n> IPaddress hostname
```

where IPaddress and hostname specify the IP address and the name of the server.

8. Start an ftp session from the server to the disk tray IP Address.
9. Place the `syslog.conf` and `hosts` files (created in Step 6 and Step 7 directly above) in the `/etc` directory of the disk tray.

See the example below.

```
# ftp 192.xxx.xxx.xxx
Name (192.xxx.xxx.xxx:root):
331 Password required for root
Password:
230 User root logged in
ftp> cd /etc
250 CWD command successful
ftp> lcd /tmp
local directory now /tmp
ftp> put syslog.conf
200 PORT command successful
150 ASCII data connection for syslog.conf (129.138.210.77,34511)
226 Transfer complete
local: syslog.conf remote: syslog.conf
20 bytes sent in 0.00021 seconds (94.81 Kbytes/s)
ftp> put hosts
200 PORT command successful
150 ASCII data connection for hosts (129.138.210.77,34513)
226 Transfer complete
local: hosts remote: hosts
23 bytes sent in 0.00045 seconds (49.47 Kbytes/s)
ftp> quit
```

10. Reboot the disk tray by typing the following:

```
# t300:/etc:<n> sync
# t300:/etc:<n> reset
Reset the system, are you sure? [N]: Y
```

11. Repeat steps 3 through 10 for every disk tray partner group (by connecting to the MCU disk tray).

## 12. Reboot the server or restart the SNMP daemon.

To restart the SNMP daemon, type the following:

```
# /etc/rc2.d/K07snmpdx stop
# /etc/rc2.d/K07snmpdx start
```

This completes setting up the disk trays for monitoring.

---

# Errata

## Sun StorEdge Component Manager

Sun StorEdge Component Manager is no longer shipped with this product. Please disregard all references to Component Manager in all manuals.

Delete the entire section titled “Graphical User Interface (GUI)” under the heading “Configuration and Monitoring Options” in *Sun StorEdge N8600 Filer Installation, Configuration, and Service Guide*.

## netstat Command

In chapter 4 of the *Sun StorEdge N8400 and N8600 Filer Administrator’s Guide*, under the `netstat` command

The `-r` option should read:

Shows the routing tables. Normally, only interface, host, network, and default routes are shown. But when this option is combined with the `-a` option, all routes will be printed, including the cache.

