



Sun StorEdge™ PCI Dual Fibre Channel Host Adapter Installation Guide

Sun Microsystems, Inc.
901 San Antonio Road
Palo Alto, CA 94303
U.S.A. 650-960-1300

Part No. 806-4199-10
May 2000, [Revision A](#)

[Send comments about this document to: docfeedback@sun.com](mailto:docfeedback@sun.com)

Copyright 2000 Sun Microsystems, Inc., 901 San Antonio Road • Palo Alto, CA 94303-4900 USA. All rights reserved.

This product or document is protected by copyright and distributed under licenses restricting its use, copying, distribution, and decompilation. No part of this product or document may be reproduced in any form by any means without prior written authorization of Sun and its licensors, if any. Third-party software, including font technology, is copyrighted and licensed from Sun suppliers.

Parts of the product may be derived from Berkeley BSD systems, licensed from the University of California. UNIX is a registered trademark in the U.S. and other countries, exclusively licensed through X/Open Company, Ltd. For Netscape Communicator™, the following notice applies: Copyright 1995 Netscape Communications Corporation. All rights reserved.

Sun, Sun Microsystems, the Sun logo, AnswerBook2, docs.sun.com, Sun Enterprise, SunVTS, StorEdge, and Solaris are trademarks, registered trademarks, or service marks of Sun Microsystems, Inc. in the U.S. and other countries. All SPARC trademarks are used under license and are trademarks or registered trademarks of SPARC International, Inc. in the U.S. and other countries. Products bearing SPARC trademarks are based upon an architecture developed by Sun Microsystems, Inc.

The OPEN LOOK and Sun™ Graphical User Interface was developed by Sun Microsystems, Inc. for its users and licensees. Sun acknowledges the pioneering efforts of Xerox in researching and developing the concept of visual or graphical user interfaces for the computer industry. Sun holds a non-exclusive license from Xerox to the Xerox Graphical User Interface, which license also covers Sun's licensees who implement OPEN LOOK GUIs and otherwise comply with Sun's written license agreements.

RESTRICTED RIGHTS: Use, duplication, or disclosure by the U.S. Government is subject to restrictions of FAR 52.227-14(g)(2)(6/87) and FAR 52.227-19(6/87), or DFAR 252.227-7015(b)(6/95) and DFAR 227.7202-3(a).

DOCUMENTATION IS PROVIDED "AS IS" AND ALL EXPRESS OR IMPLIED CONDITIONS, REPRESENTATIONS AND WARRANTIES, INCLUDING ANY IMPLIED WARRANTY OF MERCHANTABILITY, FITNESS FOR A PARTICULAR PURPOSE OR NON-INFRINGEMENT, ARE DISCLAIMED, EXCEPT TO THE EXTENT THAT SUCH DISCLAIMERS ARE HELD TO BE LEGALLY INVALID.

Copyright 2000 Sun Microsystems, Inc., 901 San Antonio Road • Palo Alto, CA 94303-4900 Etats-Unis. Tous droits réservés.

Ce produit ou document est protégé par un copyright et distribué avec des licences qui en restreignent l'utilisation, la copie, la distribution, et la décompilation. Aucune partie de ce produit ou document ne peut être reproduite sous aucune forme, par quelque moyen que ce soit, sans l'autorisation préalable et écrite de Sun et de ses bailleurs de licence, s'il y en a. Le logiciel détenu par des tiers, et qui comprend la technologie relative aux polices de caractères, est protégé par un copyright et licencié par des fournisseurs de Sun.

Des parties de ce produit pourront être dérivées des systèmes Berkeley BSD licenciés par l'Université de Californie. UNIX est une marque déposée aux Etats-Unis et dans d'autres pays et licenciée exclusivement par X/Open Company, Ltd. La notice suivante est applicable à Netscape Communicator™: Copyright 1995 Netscape Communications Corporation. Tous droits réservés.

Sun, Sun Microsystems, the Sun logo, AnswerBook2, docs.sun.com, Sun Enterprise, SunVTS, StorEdge, et Solaris sont des marques de fabrique ou des marques déposées, ou marques de service, de Sun Microsystems, Inc. aux Etats-Unis et dans d'autres pays. Toutes les marques SPARC sont utilisées sous licence et sont des marques de fabrique ou des marques déposées de SPARC International, Inc. aux Etats-Unis et dans d'autres pays. Les produits portant les marques SPARC sont basés sur une architecture développée par Sun Microsystems, Inc.

L'interface d'utilisation graphique OPEN LOOK et Sun™ a été développée par Sun Microsystems, Inc. pour ses utilisateurs et licenciés. Sun reconnaît les efforts de pionniers de Xerox pour la recherche et le développement du concept des interfaces d'utilisation visuelle ou graphique pour l'industrie de l'informatique. Sun détient une licence non exclusive de Xerox sur l'interface d'utilisation graphique Xerox, cette licence couvrant également les licenciés de Sun qui mettent en place l'interface d'utilisation graphique OPEN LOOK et qui en outre se conforment aux licences écrites de Sun.

CETTE PUBLICATION EST FOURNIE "EN L'ETAT" ET AUCUNE GARANTIE, EXPRESSE OU IMPLICITE, N'EST ACCORDEE, Y COMPRIS DES GARANTIES CONCERNANT LA VALEUR MARCHANDE, L'APTITUDE DE LA PUBLICATION A REpondre A UNE UTILISATION PARTICULIERE, OU LE FAIT QU'ELLE NE SOIT PAS CONTREFAISANTE DE PRODUIT DE TIERS. CE DENI DE GARANTIE NE S'APPLIQUERAIT PAS, DANS LA MESURE OU IL SERAIT TENU JURIDIQUEMENT NUL ET NON AVENU.



Regulatory Compliance Statements

Your Sun product is marked to indicate its compliance class:

- Federal Communications Commission (FCC) — USA
- Industry Canada Equipment Standard for Digital Equipment (ICES-003) - Canada
- Voluntary Control Council for Interference (VCCI) — Japan
- Bureau of Standards Metrology and Inspection (BSMI) — Taiwan

Please read the appropriate section that corresponds to the marking on your Sun product before attempting to install the product.

FCC Class A Notice

This device complies with Part 15 of the FCC Rules. Operation is subject to the following two conditions:

1. This device may not cause harmful interference.
2. This device must accept any interference received, including interference that may cause undesired operation.

Note: This equipment has been tested and found to comply with the limits for a Class A digital device, pursuant to Part 15 of the FCC Rules. These limits are designed to provide reasonable protection against harmful interference when the equipment is operated in a commercial environment. This equipment generates, uses, and can radiate radio frequency energy, and if it is not installed and used in accordance with the instruction manual, it may cause harmful interference to radio communications. Operation of this equipment in a residential area is likely to cause harmful interference, in which case the user will be required to correct the interference at his own expense.

Shielded Cables: Connections between the workstation and peripherals must be made using shielded cables to comply with FCC radio frequency emission limits. Networking connections can be made using unshielded twisted-pair (UTP) cables.

Modifications: Any modifications made to this device that are not approved by Sun Microsystems, Inc. may void the authority granted to the user by the FCC to operate this equipment.

FCC Class B Notice

This device complies with Part 15 of the FCC Rules. Operation is subject to the following two conditions:

1. This device may not cause harmful interference.
2. This device must accept any interference received, including interference that may cause undesired operation.

Note: This equipment has been tested and found to comply with the limits for a Class B digital device, pursuant to Part 15 of the FCC Rules. These limits are designed to provide reasonable protection against harmful interference in a residential installation. This equipment generates, uses and can radiate radio frequency energy and, if not installed and used in accordance with the instructions, may cause harmful interference to radio communications. However, there is no guarantee that interference will not occur in a particular installation. If this equipment does cause harmful interference to radio or television reception, which can be determined by turning the equipment off and on, the user is encouraged to try to correct the interference by one or more of the following measures:

- Reorient or relocate the receiving antenna.
- Increase the separation between the equipment and receiver.
- Connect the equipment into an outlet on a circuit different from that to which the receiver is connected.
- Consult the dealer or an experienced radio/television technician for help.

Shielded Cables: Connections between the workstation and peripherals must be made using shielded cables in order to maintain compliance with FCC radio frequency emission limits. Networking connections can be made using unshielded twisted pair (UTP) cables.

Modifications: Any modifications made to this device that are not approved by Sun Microsystems, Inc. may void the authority granted to the user by the FCC to operate this equipment.

ICES-003 Class A Notice - Avis NMB-003, Classe A

This Class A digital apparatus complies with Canadian ICES-003.

Cet appareil numérique de la classe A est conforme à la norme NMB-003 du Canada.

ICES-003 Class B Notice - Avis NMB-003, Classe B

This Class B digital apparatus complies with Canadian ICES-003.

Cet appareil numérique de la classe B est conforme à la norme NMB-003 du Canada.

VCCI 基準について

クラス A VCCI 基準について

クラス A VCCI の表示があるワークステーションおよびオプション製品は、クラス A 情報技術装置です。これらの製品には、下記の項目が該当します。

この装置は、情報処理装置等電波障害自主規制協議会 (VCCI) の基準に基づくクラス A 情報技術装置です。この装置を家庭環境で使用すると電波妨害を引き起こすことがあります。この場合には使用者が適切な対策を講ずるよう要求されることがあります。

クラス B VCCI 基準について

クラス B VCCI の表示  があるワークステーションおよびオプション製品は、クラス B 情報技術装置です。これらの製品には、下記の項目が該当します。

この装置は、情報処理装置等電波障害自主規制協議会 (VCCI) の基準に基づくクラス B 情報技術装置です。この装置は、家庭環境で使用することを目的としていますが、この装置がラジオやテレビジョン受信機に近接して使用されると、受信障害を引き起こすことがあります。取扱説明書に従って正しい取り扱いをしてください。

This page is intentionally left blank.

This page is intentionally left blank.

Safety Agency Compliance Statements

Read this section before beginning any procedure. The following text provides safety precautions to follow when installing a Sun Microsystems product.

Safety Precautions

For your protection, observe the following safety precautions when setting up your equipment:

- Follow all cautions and instructions marked on the equipment.
- Ensure that the voltage and frequency of your power source match the voltage and frequency inscribed on the equipment's electrical rating label.
- Never push objects of any kind through openings in the equipment. Dangerous voltages may be present. Conductive foreign objects could produce a short circuit that could cause fire, electric shock, or damage to your equipment.

Symbols

The following symbols may appear in this book:



Caution – There is risk of personal injury and equipment damage. Follow the instructions.



Caution – Hot surface. Avoid contact. Surfaces are hot and may cause personal injury if touched.



Caution – Hazardous voltages are present. To reduce the risk of electric shock and danger to personal health, follow the instructions.

On – Applies AC power to the system.

Depending on the type of power switch your device has, one of the following symbols may be used:



Off - Removes AC power from the system.



Standby – The On/Standby switch is in the standby position.

Modifications to Equipment

Do not make mechanical or electrical modifications to the equipment. Sun Microsystems is not responsible for regulatory compliance of a modified Sun product.

Placement of a Sun Product



Caution – Do not block or cover the openings of your Sun product. Never place a Sun product near a radiator or heat register. Failure to follow these guidelines can cause overheating and affect the reliability of your Sun product.



Caution – The workplace-dependent noise level defined in DIN 45 635 Part 1000 must be 70Db(A) or less.

SELV Compliance

Safety status of I/O connections comply to SELV requirements.

Power Cord Connection



Caution – Sun products are designed to work with single-phase power systems having a grounded neutral conductor. To reduce the risk of electric shock, do not plug Sun products into any other type of power system. Contact your facilities manager or a qualified electrician if you are not sure what type of power is supplied to your building.



Caution – Not all power cords have the same current ratings. Household extension cords do not have overload protection and are not meant for use with computer systems. Do not use household extension cords with your Sun product.



Caution – Your Sun product is shipped with a grounding type (three-wire) power cord. To reduce the risk of electric shock, always plug the cord into a grounded power outlet.

The following caution applies only to devices with a Standby power switch:



Caution – The power switch of this product functions as a standby type device only. The power cord serves as the primary disconnect device for the system. Be sure to plug the power cord into a grounded power outlet that is nearby the system and is readily accessible. Do not connect the power cord when the power supply has been removed from the system chassis.

System Unit Cover

You must remove the cover of your Sun computer system unit to add cards, memory, or internal storage devices. Be sure to replace the top cover before powering on your computer system.



Caution – Do not operate Sun products without the top cover in place. Failure to take this precaution may result in personal injury and system damage.

Laser Compliance Notice

Sun products that use laser technology comply with Class 1 laser requirements.

Class 1 Laser Product
Luokan 1 Laserlaite
Klasse 1 Laser Apparat
Laser Klasse 1

Einhaltung sicherheitsbehördlicher Vorschriften

Auf dieser Seite werden Sicherheitsrichtlinien beschrieben, die bei der Installation von Sun-Produkten zu beachten sind.

Sicherheitsvorkehrungen

Treffen Sie zu Ihrem eigenen Schutz die folgenden Sicherheitsvorkehrungen, wenn Sie Ihr Gerät installieren:

- Beachten Sie alle auf den Geräten angebrachten Warnhinweise und Anweisungen.
- Vergewissern Sie sich, daß Spannung und Frequenz Ihrer Stromquelle mit der Spannung und Frequenz übereinstimmen, die auf dem Etikett mit den elektrischen Nennwerten des Geräts angegeben sind.
- Stecken Sie auf keinen Fall irgendwelche Gegenstände in Öffnungen in den Geräten. Leitfähige Gegenstände könnten aufgrund der möglicherweise vorliegenden gefährlichen Spannungen einen Kurzschluß verursachen, der einen Brand, Stromschlag oder Geräteschaden herbeiführen kann.

Symbole

Die Symbole in diesem Handbuch haben folgende Bedeutung:



Achtung – Gefahr von Verletzung und Geräteschaden. Befolgen Sie die Anweisungen.



Achtung – Hohe Temperatur. Nicht berühren, da Verletzungsgefahr durch heiße Oberfläche besteht.



Achtung – Gefährliche Spannungen. Anweisungen befolgen, um Stromschläge und Verletzungen zu vermeiden.



Ein – Setzt das System unter Wechselstrom.

Je nach Netzschaltertyp an Ihrem Gerät kann eines der folgenden Symbole benutzt werden:



Aus – Unterbricht die Wechselstromzufuhr zum Gerät.



Wartezustand (Stand-by-Position) - Der Ein-/Wartezustand-Schalter steht auf Wartezustand. Änderungen an Sun-Geräten.

Nehmen Sie keine mechanischen oder elektrischen Änderungen an den Geräten vor. Sun Microsystems, übernimmt bei einem Sun-Produkt, das geändert wurde, keine Verantwortung für die Einhaltung behördlicher Vorschriften

Aufstellung von Sun-Geräten



Achtung – Um den zuverlässigen Betrieb Ihres Sun-Geräts zu gewährleisten und es vor Überhitzung zu schützen, dürfen die Öffnungen im Gerät nicht blockiert oder verdeckt werden. Sun-Produkte sollten niemals in der Nähe von Heizkörpern oder Heizluftklappen aufgestellt werden.



Achtung – Der arbeitsplatzbezogene Schalldruckpegel nach DIN 45 635 Teil 1000 beträgt 70Db(A) oder weniger.

Einhaltung der SELV-Richtlinien

Die Sicherung der I/O-Verbindungen entspricht den Anforderungen der SELV-Spezifikation.

Anschluß des Netzkabels



Achtung – Sun-Produkte sind für den Betrieb an Einphasen-Stromnetzen mit geerdetem Nulleiter vorgesehen. Um die Stromschlaggefahr zu reduzieren, schließen Sie Sun-Produkte nicht an andere Stromquellen an. Ihr Betriebsleiter oder ein qualifizierter Elektriker kann Ihnen die Daten zur Stromversorgung in Ihrem Gebäude geben.



Achtung – Nicht alle Netzkabel haben die gleichen Nennwerte. Herkömmliche, im Haushalt verwendete Verlängerungskabel besitzen keinen Überlastungsschutz und sind daher für Computersysteme nicht geeignet.



Achtung – Ihr Sun-Gerät wird mit einem dreiadrigen Netzkabel für geerdete Netzsteckdosen geliefert. Um die Gefahr eines Stromschlags zu reduzieren, schließen Sie das Kabel nur an eine fachgerecht verlegte, geerdete Steckdose an.

Die folgende Warnung gilt nur für Geräte mit Wartezustand-Netzschalter:



Achtung – Der Ein/Aus-Schalter dieses Geräts schaltet nur auf Wartezustand (Stand-By-Modus). Um die Stromzufuhr zum Gerät vollständig zu unterbrechen, müssen Sie das Netzkabel von der Steckdose abziehen. Schließen Sie den Stecker des Netzkabels an eine in der Nähe befindliche, frei zugängliche, geerdete Netzsteckdose an. Schließen Sie das Netzkabel nicht an, wenn das Netzteil aus der Systemeinheit entfernt wurde.

Gehäuseabdeckung

Sie müssen die obere Abdeckung Ihres Sun-Systems entfernen, um interne Komponenten wie Karten,

Speicherchips oder Massenspeicher hinzuzufügen. Bringen Sie die obere Gehäuseabdeckung wieder an, bevor Sie Ihr System einschalten.



Achtung – Bei Betrieb des Systems ohne obere Abdeckung besteht die Gefahr von Stromschlag und Systemschäden.

Einhaltung der Richtlinien für Laser

Sun-Produkte, die mit Laser-Technologie arbeiten, entsprechen den Anforderungen der Laser Klasse 1.

Class 1 Laser Product
Luokan 1 Laserlaite
Klasse 1 Laser Apparat
Laser Klasse 1

Conformité aux normes de sécurité

Ce texte traite des mesures de sécurité qu'il convient de prendre pour l'installation d'un produit Sun Microsystems.

Mesures de sécurité

Pour votre protection, veuillez prendre les précautions suivantes pendant l'installation du matériel :

- Suivre tous les avertissements et toutes les instructions inscrites sur le matériel.
- Vérifier que la tension et la fréquence de la source d'alimentation électrique correspondent à la tension et à la fréquence indiquées sur l'étiquette de classification de l'appareil.
- Ne jamais introduire d'objets quels qu'ils soient dans une des ouvertures de l'appareil. Vous pourriez vous trouver en présence de hautes tensions dangereuses. Tout objet conducteur introduit de la sorte pourrait

produire un court-circuit qui entraînerait des flammes, des risques d'électrocution ou des dégâts matériels.

Symboles

Vous trouverez ci-dessous la signification des différents symboles utilisés :



Attention: – risques de blessures corporelles et de dégâts matériels. Veuillez suivre les instructions.



Attention: – surface à température élevée. Évitez le contact. La température des surfaces est élevée et leur contact peut provoquer des blessures corporelles.



Attention: – présence de tensions dangereuses. Pour éviter les risques d'électrocution et de danger pour la santé physique, veuillez suivre les instructions.



MARCHE – Votre système est sous tension (courant alternatif).

Un des symboles suivants sera peut-être utilisé en fonction du type d'interrupteur de votre système:



ARRET - Votre système est hors tension (courant alternatif).



VEILLEUSE – L'interrupteur Marche/Veilleuse est en position « Veilleuse ».

Modification du matériel

Ne pas apporter de modification mécanique ou électrique au matériel. Sun Microsystems n'est pas responsable de la conformité réglementaire d'un produit Sun qui a été modifié.

Positionnement d'un produit Sun



Attention: – pour assurer le bon fonctionnement de votre produit Sun et pour l'empêcher de surchauffer, il convient de ne pas obstruer ni recouvrir les ouvertures prévues dans l'appareil. Un produit Sun ne doit jamais être placé à proximité d'un radiateur ou d'une source de chaleur.



Attention: – Le niveau de pression acoustique au poste de travail s'élève selon la norme DIN 45 635 section 1000, à 70 dB (A) ou moins.

Conformité SELV

Sécurité : les raccordements E/S sont conformes aux normes SELV.

Connexion du cordon d'alimentation.



Attention: – les produits Sun sont conçus pour fonctionner avec des alimentations monophasées munies d'un conducteur neutre mis à la terre. Pour écarter les risques d'électrocution, ne pas brancher de produit Sun dans un autre type d'alimentation secteur. En cas de doute quant au type d'alimentation électrique du local, veuillez vous adresser au directeur de l'exploitation ou à un électricien qualifié.



Attention: – tous les cordons d'alimentation n'ont pas forcément la même puissance nominale en matière de courant. Les rallonges d'usage domestique n'offrent pas de protection contre les surcharges et ne sont pas prévues pour les systèmes d'ordinateurs. Ne pas utiliser de rallonge d'usage domestique avec votre produit Sun.



Attention: – votre produit Sun a été livré équipé d'un cordon d'alimentation à trois fils (avec prise de terre). Pour écarter tout risque d'électrocution, branchez toujours ce cordon dans une prise mise à la terre.

L'avertissement suivant s'applique uniquement aux systèmes équipés d'un interrupteur VEILLEUSE:



Attention: – le commutateur d'alimentation de ce produit fonctionne comme un dispositif de mise en veille uniquement. C'est la prise d'alimentation qui sert à mettre le produit hors tension. Veillez donc à installer le produit à proximité d'une prise murale facilement accessible. Ne connectez pas la prise d'alimentation lorsque le châssis du système n'est plus alimenté.

Couvercle

Pour ajouter des cartes, de la mémoire, ou des unités de stockage internes, vous devrez démonter le couvercle de l'unité système Sun. Ne pas oublier de remettre ce couvercle en place avant de mettre le système sous tension.



Attention: – il est dangereux de faire fonctionner un produit Sun sans le couvercle en place. Si l'on néglige cette précaution, on encourt des risques de blessures corporelles et de dégâts matériels.

Conformité aux certifications Laser

Les produits Sun qui font appel aux technologies lasers sont conformes aux normes de la classe 1 en la matière.

Class 1 Laser Product
Luokan 1 Laserlaitte
Klasse 1 Laser Apparat
Laser Klasse 1

Normativas de seguridad

El siguiente texto incluye las medidas de seguridad que se deben seguir cuando se instale algún producto de Sun Microsystems.

Precauciones de seguridad

Para su protección observe las siguientes medidas de seguridad cuando manipule su equipo:

- Siga todas las avisos e instrucciones marcados en el equipo.
- Asegúrese de que el voltaje y la frecuencia de la red eléctrica concuerdan con las descritas en las etiquetas de especificaciones eléctricas del equipo.
- No introduzca nunca objetos de ningún tipo a través de los orificios del equipo. Pueden haber voltajes peligrosos. Los objetos extraños conductores de la electricidad pueden producir cortocircuitos que provoquen un incendio, descargas eléctricas o daños en el equipo.

Símbolos

En este libro aparecen los siguientes símbolos:



Precaución – Existe el riesgo de lesiones personales y daños al equipo. Siga las instrucciones.



Precaución – Superficie caliente. Evite el contacto. Las superficies están calientes y pueden causar daños personales si se tocan.



Precaución – Voltaje peligroso presente. Para reducir el riesgo de descarga y daños para la salud siga las instrucciones.



Encendido – Aplica la alimentación de CA al sistema.

Según el tipo de interruptor de encendido que su equipo tenga, es posible que se utilice uno de los siguientes símbolos:



Apagado - Elimina la alimentación de CA del sistema.



En espera – El interruptor de Encendido/En espera se ha colocado en la posición de En espera.

Modificaciones en el equipo

No realice modificaciones de tipo mecánico o eléctrico en el equipo. Sun Microsystems no se hace responsable del cumplimiento de las normativas de seguridad en los equipos Sun modificados.

Ubicación de un producto Sun



Precaución – Para asegurar la fiabilidad de funcionamiento de su producto Sun y para protegerlo de sobrecalentamientos no deben obstruirse o taparse las rejillas del equipo. Los productos Sun nunca deben situarse cerca de radiadores o de fuentes de calor.



Precaución – De acuerdo con la norma DIN 45 635, Parte 1000, se admite un nivel de presión acústica para puestos de trabajo máximo de 70Db(A).

Cumplimiento de la normativa SELV

El estado de la seguridad de las conexiones de entrada/salida cumple los requisitos de la normativa SELV.

Conexión del cable de alimentación eléctrica



Precaución – Los productos Sun están diseñados para trabajar en una red eléctrica monofásica con toma de tierra. Para reducir el riesgo de descarga eléctrica, no conecte los productos Sun a otro tipo de sistema de alimentación eléctrica. Póngase en contacto con el responsable de mantenimiento o con un electricista cualificado si no está seguro del sistema de alimentación eléctrica del que se dispone en su edificio.



Precaución – No todos los cables de alimentación eléctrica tienen la misma capacidad. Los cables de tipo doméstico no están provistos de protecciones contra sobrecargas y por tanto no son apropiados para su uso con computadores. No utilice alargadores de tipo doméstico para conectar sus productos Sun.



Precaución – Con el producto Sun se proporciona un cable de alimentación con toma de tierra. Para reducir el riesgo de descargas eléctricas conéctelo siempre a un enchufe con toma de tierra.

La siguiente advertencia se aplica solamente a equipos con un interruptor de encendido que tenga una posición "En espera":



Precaución – El interruptor de encendido de este producto funciona exclusivamente como un dispositivo de puesta en espera. El enchufe de la fuente de alimentación está diseñado para ser el elemento primario de desconexión del equipo. El equipo debe instalarse cerca del enchufe de forma que este último pueda ser fácil y rápidamente accesible. No conecte el cable de alimentación cuando se ha retirado la fuente de alimentación del chasis del sistema.

internos. Asegúrese de cerrar la tapa superior antes de volver a encender el equipo.



Precaución – Es peligroso hacer funcionar los productos Sun sin la tapa superior colocada. El hecho de no tener en cuenta esta precaución puede ocasionar daños personales o perjudicar el funcionamiento del equipo.

Aviso de cumplimiento con requisitos de láser

Los productos Sun que utilizan la tecnología de láser cumplen con los requisitos de láser de Clase 1.

Class 1 Laser Product
Luokan 1 Laserlaite
Klasse 1 Laser Apparat
Laser Klasse 1

GOST-R Certification Mark

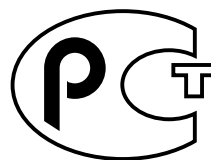

Tapa de la unidad del sistema

Debe quitar la tapa del sistema cuando sea necesario añadir tarjetas, memoria o dispositivos de almacenamiento

This page is intentionally left blank.

Declaration of Conformity

Compliance ID: Crystal-PCI

Product Name: Sun StorEdge PCI Dual Fibre Channel Host Adapter

This product has been tested and complies with the following rules and requirements.

EMC

USA—FCC Class B

This device complies with Part 15 of the FCC Rules. Operation is subject to the following two conditions:

1. This device may not cause harmful interference.
2. This device must accept any interference received, including interference that may cause undesired operation.

European Union—EC

This equipment complies with the following requirements of the EMC Directive 89/336/EEC:

EN55022/CISPR22 (1985)		Class B
EN50082-1	IEC801-2 (1991)	4 kV (Direct), 8 kV (Air)
	IEC801-3 (1984)	3 V/m
	IEC801-4 (1988)	1.0 kV Power Lines, 0.5 kV Signal Lines
EN61000-3-2/IEC1000-3-2 (1994)		Pass

Safety

This equipment complies with the following requirements of the Low Voltage Directive 73/23/EEC:

EC Type Examination Certificates:

EN60950/IEC950 (1993)

EN60950 w/Nordic Deviations

Supplementary Information

This product was tested and complies with all the requirements for the CE Mark (when connected to a Sun workstation or server).

/S/

Dennis P. Symanski
Manager, Product Compliance

Sun Microsystems, Inc.
901 San Antonio Road, M/S UMPK15-102
Palo Alto, CA 94303, USA

Tel: 650-786-3255
Fax: 650-786-3723

DATE

/S/

John Shades
Quality Assurance Manager

Sun Microsystems Scotland, Limited
Springfield, Linlithgow
West Lothian, EH49 7LR
Scotland, United Kingdom

Tel: 0506-670000
Fax: 0506 760011

DATE

This page is intentionally left blank.

Contents

Preface xxi

1. Installation 1-1

- 1.1 Software Requirements 1-1
 - 1.1.1 Device Drivers 1-1
 - 1.1.2 SunVTS qlctest 1-2
- 1.2 Tools and Equipment Needed 1-3
- 1.3 Preparing for Installation 1-3
 - 1.3.1 Sun Enterprise Systems 1-3
 - 1.3.2 Preparing for a Sun StorEdge A5x00 Installation 1-4
- 1.4 Installing the Host Adapter 1-7
- 1.5 Testing the Installation 1-12
 - 1.5.1 SunVTS 1-12
 - 1.5.2 Testing Procedure 1-12

A. Specifications A-1

- A.1 PCI Card A-1
- A.2 Fibre Channel Interface Specifications A-1
- A.3 Performance Specifications A-2
- A.4 Power Requirements A-3
- A.5 Physical Dimensions A-3

- A.6 Regulatory Compliance A-4
- A.7 PCI Edge Connector Pin Definitions:
32-Bit Cards A-5
- A.8 PCI Edge Connector Pin Definitions:
64-Bit Cards A-7

Preface

The *Sun StorEdge PCI Dual Fibre Channel Host Adapter Installation Guide* describes how to install Sun StorEdge™ PCI Dual Fibre Channel Host Adapters. These instructions are designed for an experienced system administrator or trained service provider.

Using UNIX Commands

This document may not contain information on basic UNIX® commands and procedures such as shutting down the system, booting the system, and configuring devices.

See one or more of the following for this information:

- *Solaris Handbook for Sun Peripherals*
- AnswerBook™ online documentation for the Solaris™ software environment
- Other software documentation that you received with your system

Typographic Conventions

Typeface	Meaning	Examples
AaBbCc123	The names of commands, files, and directories; on-screen computer output	Edit your <code>.login</code> file. Use <code>ls -a</code> to list all files. % You have mail.
AaBbCc123	What you type, when contrasted with on-screen computer output	% su Password:
<i>AaBbCc123</i>	Book titles, new words or terms, words to be emphasized	Read Chapter 6 in the <i>User's Guide</i> . These are called <i>class</i> options. You <i>must</i> be superuser to do this.
	Command-line variable; replace with a real name or value	To delete a file, type <code>rm filename</code> .

Shell Prompts

Shell	Prompt
C shell	<i>machine_name%</i>
C shell superuser	<i>machine_name#</i>
Bourne shell and Korn shell	\$
Bourne shell and Korn shell superuser	#

Related Documentation

Application	Title	Part Number
Diagnostic Testing	<i>SunVTS™ 3.4 User's Guide</i>	806-2884
	<i>SunVTS 3.4 Test Reference</i>	806-2885
	<i>SunVTS 4.0 User's Guide</i>	806-2057
	<i>SunVTS 4.0 Test Reference Manual</i>	806-2058
Sun Enterprise™ Systems	<i>PCI I/O Board Installation and Component Replacement</i>	805-1372
Sun StorEdge Disk Arrays	<i>Sun StorEdge A5000 Hardware Configuration Guide</i>	805-0264

Accessing Sun Documentation Online

The `docs.sun.comsm` web site enables you to access Sun technical documentation on the Web. You can browse the `docs.sun.com` archive or search for a specific book title or subject at:

<http://docs.sun.com>

Ordering Sun Documentation

Fatbrain.com, an Internet professional bookstore, stocks select product documentation from Sun Microsystems, Inc.

For a list of documents and how to order them, visit the Sun Documentation Center on Fatbrain.com at:

<http://www1.fatbrain.com/documentation/sun>

Sun Welcomes Your Comments

Sun is interested in improving its documentation and welcomes your comments and suggestions. You can email your comments to Sun at:

`docfeedback@sun.com`

Please include the part number of your document in the subject line of your email.

Installation

This chapter describes how to install the Sun StorEdge™ PCI Dual Fibre Channel Host Adapter in a system.

1.1 Software Requirements

1.1.1 Device Drivers

The minimum Solaris™ operating environment releases to support the device drivers for the Sun StorEdge PCI Dual Fibre Channel Host Adapter are:

- Solaris 7 11/99
- Solaris 8 6/00

TABLE 1-1 Required Packages For Installation

32-bit	64-bit	Description
SUNWfctl or	SUNWfctlx	Fibre Channel transport drivers
SUNWfcpx or	SUNWfcpx	FCP (SCSI over Fibre Channel)
SUNWqlc or	SUNWqlcx	Driver for the Sun StorEdge PCI Dual Fibre Channel Host Adapter boards
SUNWcip or	SUNWcipx	IP over Fibre Channel drivers

All of the above drivers are bundled with Solaris 8. See TABLE 1-2 for driver availability with Solaris 7.

TABLE 1-2 Solaris 7 Availability

Package	Solaris 7 Release	Availability
SUNWfctl	Solaris 7 11/99	Bundled
SUNWfcp	Solaris 7 11/99	Bundled
SUNWqlc	Solaris 7	Unbundled
SUNWfcip	Solaris 7	Unbundled

- Once installed, Sun StorEdge PCI Dual Fibre Channel Host Adapter boards will have device paths similar to
`/devices/pci@b,2000/pci@2/SUNW,qlc5.`
- Under these nodes, there will be one instance of the `fp` driver that has a device node similar to:
`/devices/pci@b,2000/pci@2/SUNW,qlc@5/fp@0,0`
- `fp` driver also has a `devctl` node for administrative use with a name similar to
`/devices/pci@b,2000/pci@2/SUNW,qlc@5/fp@0,0:devctl`
- For devices found, the nodes are created depending on the WWN of the device. For a WWN of 2100002037182670, the device path is similar to
`/devices/pci@b,2000/pci@2/SUNW,qlc@5/fp@0,0/ssd@2100003027182670,0:a`
- Go to the <http://docs.sun.com> Web site, click Storage, and read the *Sun StorEdge PCI Dual Fibre Channel Host Adapter Product Notes* to obtain software patch IDs.
- The Fibre Channel transport device driver patches are at <http://sunsolve.Sun.COM>

1.1.2 SunVTS qlctest

- SunVTS must already be installed before you can do a `pkgadd` of the `qlctest`.
- *Release Notes* are included in the `SUNWvtsqc` package.

TABLE 1-3 qlctest Dependencies

SunVTS Release	qlctest Package
3.4	SUNWvtsqc
4.0	SUNWvtsqc

1.2 Tools and Equipment Needed

You may need to order fiber optic cables. You can order them in the following lengths:

- 2-meter, part number X973A
- 15-meter, part number X978A

You will also need:

- A No. 2 Phillips screwdriver
- An antistatic wrist strap
- A padded antistatic mat

1.3 Preparing for Installation

1.3.1 Sun Enterprise Systems

The Sun StorEdge PCI Dual Fibre Channel Host Adapter does not support JTAG. When you install the PCI host adapter in a Sun Enterprise™ system, be sure that the corresponding PCI riser card has the JTAG jumper removed (FIGURE 1-1).

Note – If the JTAG jumper is installed, the PCI I/O board will not be recognized or initialized during POST (power-on self-test) nor will it subsequently be recognized by the operating system.

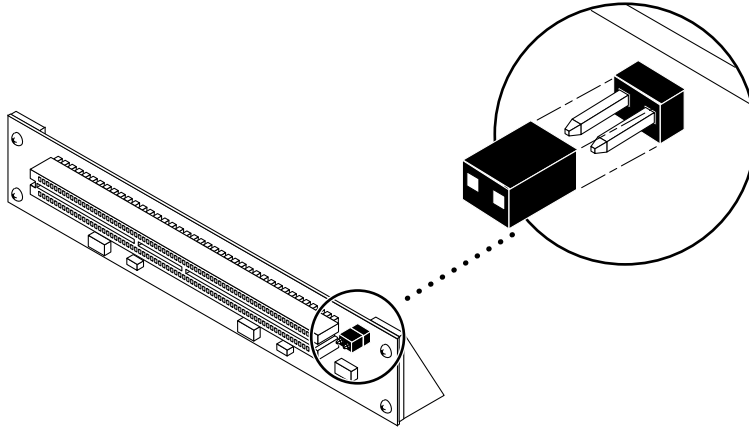

FIGURE 1-1 JTAG Jumper

1.3.2 Preparing for a Sun StorEdge A5x00 Installation

1. Use the array's front panel module (FPM) to ensure that the firmware level of the interface boards is at least 1.05.

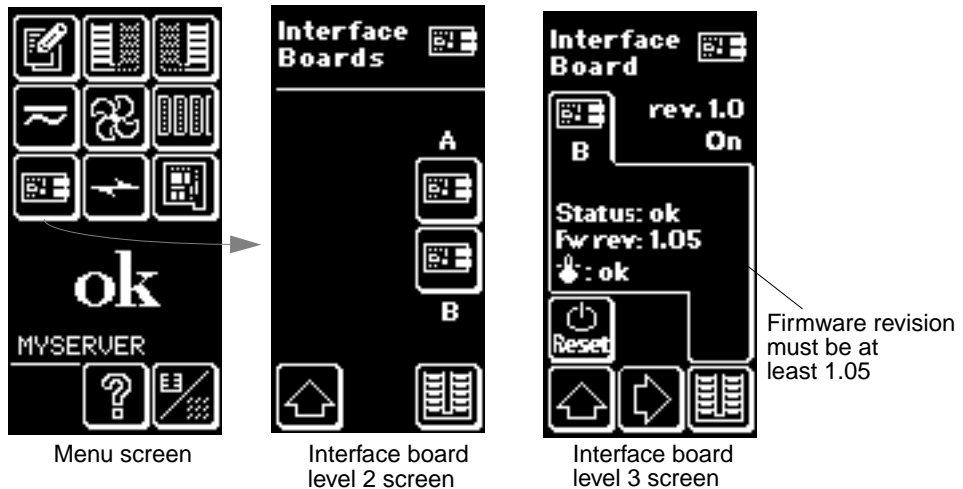

FIGURE 1-2 Checking the Sun StorEdge A5x00 Array Interface Board Firmware Level

If the firmware level is less than 1.05, you must upgrade the firmware using an S-Bus-based host system before you can connect the array to the Sun StorEdge PCI Dual Fibre Channel Host Adapter. The instructions for obtaining the upgrade patch are in Step 3.

2. Determine which version of the Solaris™ operating environment you are using.

Look at the `/etc/release` file and make sure the operating environment installed is at least Solaris 7. If you do not have an `/etc/release` file, you probably need to upgrade your operating environment to at least Solaris 7.

3. Get the required software:

- qlc driver
- SunVTS™ qlctest

a. Go to the <http://docs.sun.com> Web site.

b. Click *Storage* and read the *Sun StorEdge A5000 Installation Supplement and the Sun StorEdge PCI Dual Fibre Channel Host Adapter Product Notes*.

The *Product Notes* will give you the software patch IDs.

c. Download the software patches from:

<http://sunsolve.sun.com>

Contact your support service provider if you cannot access these Web sites.

Note – Be sure to read and follow the directions in the README file for each patch.

4. Log in as `root` on your system.

5. Verify that the `SUNWses`, `SUNWssad`, and `SUNWvts` packages have been installed on your system.

Use the `/usr/bin/pkginfo` command and `grep` for each of the above patches. For example:

```
# /usr/bin/pkginfo | grep SUNWvts
system SUNWvts Online Validation Test Suite
```

If you are missing any of these patches, you can get them from the *Updates for Solaris Operating Environment*.

6. Exit the operating environment.

To inform any mounted users that the system will be going down, use the `shutdown` command. Otherwise, use the `init 0` command. See the Man Pages for these commands or the Solaris AnswerBook online documentation.

7. Power off the system.

Refer to the service documentation that came with your system.



Caution – Do not disconnect the power cord at this time. This connection provides the ground path necessary to remove and install printed circuit boards and components without damage.

8. Choose a slot into which to install the host adapter.

Follow the procedures in the documentation supplied with your system.

For systems that have more than one system board, you must also select and remove a system board that has an available PCI slot. Refer to your system documentation for specific instructions.

9. Attach the antistatic wrist strap to your wrist and to a metal component on the system chassis.

The wrist strap between you and the chassis provides the ground path necessary to safely remove and install the printed circuit boards and components without damaging them.

10. For systems with a standby-type power switch, disconnect the power cord.

Standby-type power switches have a  icon.

11. Open the system.

Refer to your system documentation for specific instructions.



Caution – If you need to remove a system board for installation, place the board on a padded antistatic mat to prevent damage.

1.4 Installing the Host Adapter

1. Pull the two dust covers out of the 1x9 optical transceiver (OT) connectors (FIGURE 1-3).

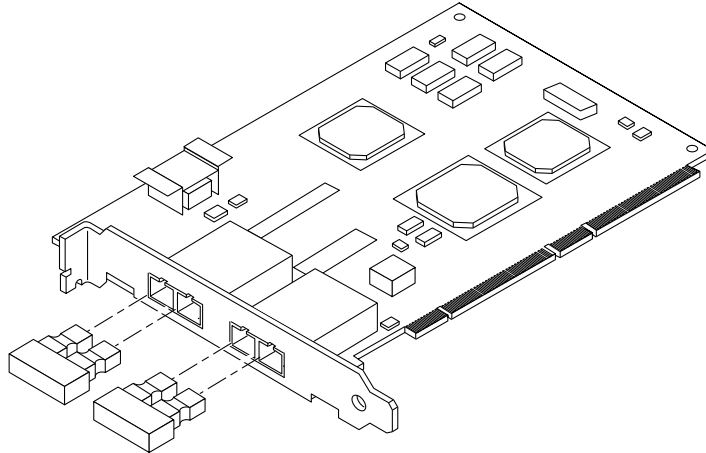

FIGURE 1-3 Sun StorEdge PCI Dual Fibre Channel Host Adapter Dust Covers

2. **Install the host adapter in the PCI slot you have chosen.**
Installation details vary for each system. Refer to your system documentation for specific instructions.
3. **Reassemble the system.**
Refer to your system documentation for specific instructions.
4. **Disconnect the wrist strap.**
5. **Push the fiber optic cable connector into the OT connector until you hear a click (FIGURE 1-4).**



Caution – Fiber optic cables have keyed connectors; they can only be inserted into OT connectors as shown in FIGURE 1-4.

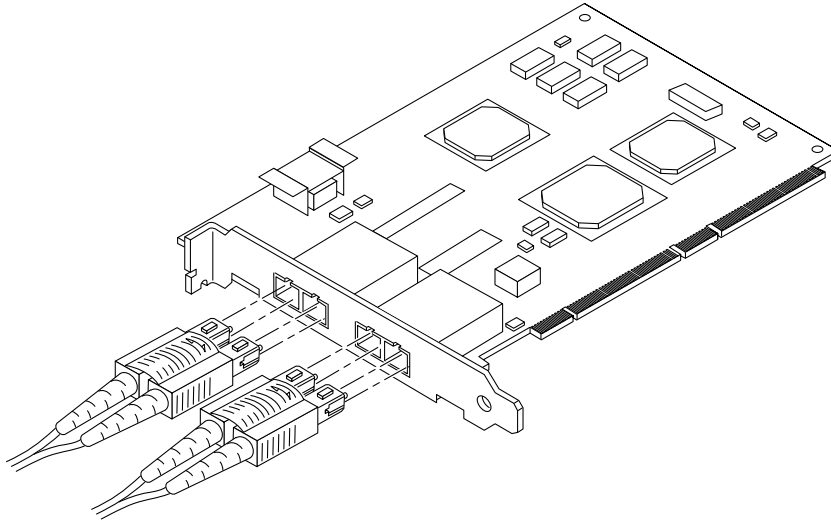

FIGURE 1-4 Connecting a Fiber Optic Cable to an OT Connector

6. Connect the other end of the fiber optic cable to a device such as a disk array or hub.



Caution – In multiple-initiator configurations:

- When a Sun StorEdge PCI Dual Fibre Channel Host Adapter is directly connected to a Sun StorEdge A5x00, each port on the host adapter must be connected to a separate loop on the A5x00.
 - When a Fibre Channel Arbitrated Loop (FCAL) hub is placed between a Sun StorEdge PCI Dual Fibre Channel Host Adapter and a Sun StorEdge A5x00, more than one host adapter on the same loop may be used.
-

Refer to the documentation that came with the device for specific instructions.

7. Power on your peripherals and then your system.

Note – If your system starts to reboot, interrupt the reboot process by pressing the Stop-A keys.

The system should now be at the `ok` prompt. If a `>` prompt is showing, type `n` to switch to the `ok` prompt.

8. Make sure that the system recognizes the host adapter.

Use *either* Method A *or* Method B.

- a. **For Method A, see FIGURE 1-5 and FIGURE 1-6.**
FIGURE 1-6 is a continuation of FIGURE 1-5.
- b. **For Method B, see FIGURE 1-7.**

```

ok show-devs
/counter-timer@f,1c00
/pci@f,2000
/pci@f,4000
/counter-timer@e,1c00
/fhc@e,f8800000
/pci@e,2000
/pci@e,4000
/counter-timer@b,3c00
/fhc@a,f8800000
/sbus@a,0
/counter-timer@3,3c00
/sbus@3,0
/fhc@2,f8800000
/disk-board@6,0
/SUNW,UltraSPARC-II@5,0
/SUNW,UltraSPARC-ii@4,0
/fhc@4,f8800000
/SUNW,UltraSPARC-II@1,0
/SUNW,UltraSPARC-11@0,0
/fhc@0,f8800000
/central@1f,0
/virtual-memory
/memory@0,0
/aliases
/options
/openprom
/chosen
/packages
/pci@f,4000/SUNW,isptwo@3
/pci@f,4000/SUNW,isptwo@3/st
/pci@f,4000/SUNW,isptwo@3/sd
/fhc@e,f8800000/sbus-speed@0,500000
/fhc@e,f8800000/eeeprom@0,300000
/fhc@e,f8800000/flashprom@0,0
/fhc@e,f8800000/environment@0,400000
/fhc@e,f8800000/ac@0,1000000
/pci@e,2000/pci@2
/pci@e,2000/pci@2/SUNW,qlc@5
/pci@e,2000/pci@2/SUNW,qlc@4
/pci@e,2000/pci@2/SUNW,qlc@5/fp@0,0
/pci@e,2000/pci@2/SUNW,qlc@5/fp@0,0/disk
/pci@e,2000/pci@2/SUNW,qlc@4/fp@0,0
/pci@e,2000/pci@2/SUNW,qlc@4/fp@0,0/disk

```

FIGURE 1-5 System Recognition of the Host Adapter, Method A, Part 1

```

ok apply show-children /pci@e,2000/pci@2/SUNW,qlc@5
LiD HA --- Port WWN --- ----- Disk description ----
_3d 3d 5080020000025a5a SUN ----- SENA ----- 1.09PZX
_30 30 21000020370e6891 SEAGATE - ST19171FCSUN9.0G177E9823U86993
_33 33 21000020370e964f SEAGATE - ST19171FCSUN9.0G177E9823V06714
_36 36 21000020370e92c9 SEAGATE - ST19171FCSUN9.0G177E9823V11851
_2d 2d 5080020000025a59 SUN ----- SENA ----- 1.09PZX
_23 23 21000020370e930d SEAGATE - ST19171FCSUN9.0G177E9823V12050
_26 26 21000020370e9b08 SEAGATE - ST19171FCSUN9.0G177E9823V15713

```

FIGURE 1-6 System Recognition of the Host Adapter, Method A, Part 2

In FIGURE 1-6, /pci@1f,0/pci@1/pci@1/SUNW,qlc@4 is one port on the Sun StorEdge PCI Dual Fibre Channel Host Adapter and the disks are in a Sun StorEdge A5000 array (SENA).

```

ok select /pci@e,2000/pci@2/SUNW,qlc@5
ok show-children
LiD HA --- Port WWN --- ----- Disk description ----
_3d 3d 5080020000025a5a SUN ----- SENA ----- 1.09PZX
_30 30 21000020370e6891 SEAGATE - ST19171FCSUN9.0G177E9823U86993
_33 33 21000020370e964f SEAGATE - ST19171FCSUN9.0G177E9823V06714
_36 36 21000020370e92c9 SEAGATE - ST19171FCSUN9.0G177E9823V11851
_2d 2d 5080020000025a59 SUN ----- SENA ----- 1.09PZX
_23 23 21000020370e930d SEAGATE - ST19171FCSUN9.0G177E9823V12050
_26 26 21000020370e9b08 SEAGATE - ST19171FCSUN9.0G177E9823V15713

```

FIGURE 1-7 System Recognition of the Host Adapter, Method B

Note – The probe-scsi-all command does not function identically on all platforms, and does not in all cases probe for fiber channel devices. The probe-fcal-all command exists only on Sun Enterprise™ systems.

9. Reboot your system using the boot -r command.

1.5 Testing the Installation

1.5.1 SunVTS

Refer to the SunVTS documents in TABLE 1-4.

TABLE 1-4 Sun VTS Documents

Application	Title	Part Number
Diagnostic Testing	<i>SunVTS 3.4 User's Guide</i>	806-2884
	<i>SunVTS 3.4 Test Reference</i>	806-2885
	<i>Sun VTS 4.0 User's Guide</i>	806-2057
	<i>Sun VTS 4.0 Test Reference Manual</i>	806-2058

SunVTS is a diagnostic program that exercises your system to verify the functionality, reliability, and configuration of your host adapter. You will need to install both the 32- and 64-bit versions of SunVTS. In addition, you will need the SunVTS qlc test package—SUNWvtsqc—installed.

Once you have the SUNWvtsqc package installed, you may run the qlctest under SunVTS.

1.5.2 Testing Procedure

1. To invoke SunVTS locally on a system running CDE, type the following as root:

```
# cd /opt/SUNWvts/bin
# ./sunvts
```

2. From the SunVTS menus select the following:
 - a. Select devices None and select intervention.
 - b. Select mode Functional test.
 - c. Select HostAdapters qlcx where x is the qlc # of the qlc port you want to run this test against.

d. If you want to run the external loopback test, place a loopback plug into the qlc port that you want to test.

If you do not have an external loopback plug, you can make one by taking apart a fiber cable and plug the same cable into the transmitter and receiver of the qlc port.

e. Right click on the qlc test and select Test Parameter Options.

f. Enable the External Loopback Test.

Note – If you do not use a loopback plug, you can connect the qlc port to storage devices. In such a case, you will be testing both the qlc and the entire fiber loop.

g. Select Start to start the test.

Note – If you select only the external loopback test, the different version diagnostic tests will not be run and the delay time between tests will be set to zero. This is a good way to test your fiber loop if you leave the qlc port attached to storage devices.

This page is intentionally left blank.

Specifications

A.1 PCI Card

The Sun StorEdge PCI Dual Fibre Channel Host Adapter is a Fibre Channel PCI card with two onboard optical transceivers. This host adapter is PCI Version 2.1 compliant.

A.2 Fibre Channel Interface Specifications

TABLE A-1 Fibre Channel Specifications

Specification	Value
ANSI Standards	Fibre Channel FC-PH X3.230-1995
	SCSI Fibre Channel Protocol X3.269-1996
Optical transceiver	100 MBytes/sec (1 Gbits/sec) full duplex
	Shortwave laser, Module Definition 5
Fiber cable type	50 micrometer multimode
Maximum cable length	500 meters

A.3 Performance Specifications

The following specifications must be verified.

TABLE A-2 Performance Specifications

Feature	Specification
PCI clock	66 MHz maximum
PCI data burst transfer rate	528 MBytes/sec burst rate
FC-AL transfer rate payload	100 MBytes/sec
PCI data/address lines	AD63-0
PCI modes	Master/slave
Capacitance per PCI signal line	≤10 pF, except for CLK between 5 to 12 pF and IDSEL ≤8 pF
FC-AL Interface	1 Gbit optical (1.026 bits/sec)

A.4 Power Requirements

TABLE A-3 Power Requirements

Specification	Rating
Voltage and current	5V 5%,3A
Ripple	100 mV

A.5 Physical Dimensions

TABLE A-4 Physical Dimensions

Height	Width	Depth	Weight
15 mm	106.68 mm	174.63 mm	170.1 g
0.6 in.	4.2 in.	6.875 in.	6.0 oz.

A.6 Regulatory Compliance

TABLE A-5 Requirements Met or Exceeded by the Host Adapter

Category	Rating
Safety	UL 1950
	CSA 950
	TUV EN 60950
	Class 1 laser requirements per CFR 21, Part 1040 and IEC 825
RFI/EMI	FCC Class B
	DOC Class B
	VCCI Class B
	EMC Directive (89/336/EEC), EN55022
Immunity	EMC Directive (89/336/EEC), EN55082-1

A.7 PCI Edge Connector Pin Definitions: 32-Bit Cards

TABLE A-6 PCI Edge Connector Pin Definitions, 32-Bit Cards (Top)

Pin	Description	Pin	Description	Pin	Description
1	-12V	22	GND	43	+3.3V
2	TCK	23	AD27	44	C_BE1
3	GND	24	AD25	45	AD14
4	TDO	25	+3.3V	46	GND
5	+5V	26	C_BE3	47	AD12
6	+5V	27	AD23	48	AD10
7	INTB	28	GND	49	GND
8	INTD	29	AD21	50	KEYWAY
9	GND (PRSNT1)	30	AD19	51	KEYWAY
10	RESERVED	31	+3.3V	52	AD08
11	GND (PRSNT2)	32	AD17	53	AD07
12	KEYWAY	33	C_BE2	54	+3.3V
13	KEYWAY	34	GND	55	AD05
14	RESERVED	35	IRDY	56	AD03
15	GND	36	+3.3V	57	GND
16	CLK	37	DEVSEL	58	AD01
17	GND	38	GND	59	+5V
18	REQ	39	LOCK	60	ACK64
19	+3V/+5V	40	PERR	61	+5V
20	AD31	41	+3.3V	62	+5V
21	AD29	42	SERR		

TABLE A-7 PCI Edge Connector Pin Definitions, 32-Bit Cards(Bottom)

Pin	Description	Pin	Description	Pin	Description
1	TRST	22	AD28	43	PAR
2	+12V	23	AD26	44	AD15
3	TMS	24	GND	45	+3.3V
4	TDI	25	AD24	46	AD13
5	+5V	26	IDSEL	47	AD11
6	INTA	27	+3.3V	48	GND
7	INTC	28	AD22	49	AD09
8	+5V	29	AD20	50	KEYWAY
9	RESERVED	30	GND	51	KEYWAY
10	+5V	31	AD18	52	C_BE0
11	RESERVED	32	AD16	53	+3.3V
12	KEYWAY	33	+3.3V	54	AD06
13	KEYWAY	34	FRAME	55	AD04
14	RESERVED	35	IGND	56	GND
15	RST	36	TRDY	57	GND
16	+5V	37	GND	58	AD02
17	GNt	38	STOP	59	+5V
18	GND	39	+3.3V	60	REQ64
19	RESERVED	40	SDONE	61	+5V
20	AD30	41	SBO	62	+5V
21	+3.3V	42	GND		

A.8 PCI Edge Connector Pin Definitions: 64-Bit Cards

TABLE A-8 PCI Expansion Board Pinout—Universal Board

Pin	Side B	Side A	Pin	Side B	Side A
1	-12V	TRST#	26	C/BE[3]#	IDSEL
2	TCK	+12V	27	AD[23]	+3.3V
3	Ground	TMS	28	Ground	AD[22]
4	TDO	TDI	29	AD[21]	AD[20]
5	+5V	+5V	30	AD[19]	Ground
6	+5V	INTA#	31	+3.3V	AD[18]
7	INTB#	INTC#	32	AD[17]	AD[16]
8	INTD#	+5V	33	C/BE[2]#	+3.3V
9	PRSENT1#	Reserved	34	Ground	FRAME#
10	Reserved	+Vi/O	35	IRDY#	Ground
11	PRSENT2#	Reserved	36	+3.3V	TRDY#
12	Keyway	Keyway	37	DEVSEL#	Ground
13	Keyway	Keyway	38	Ground	STOP#
14	Reserved	3.3Vaux	39	LOCK#	+3.3V
15	Ground	RST#	40	PERR#	SDONE
16	CLK	+Vi/O	41	+3.3V	SBO#
17	Ground	GNT#	42	SERR#	Ground
18	REQ#	Ground	43	+3.3V	PAR
19	+Vi/O	PME#	44	C/BE[1]#	AD[15]
20	AD[31]	AD[30]	45	ad[14]	+3.3V
21	AD[29]	+3.3V	46	Ground	AD[13]
22	Ground	AD[28]	47	AD[12]	AD[11]
23	AD[27]	AD[26]	48	AD[10]	Ground
24	AD[25]	Ground	49	M66EN	AD[09]
25	+3.3V	AD[24]	50	Keyway	Keyway

TABLE A-9 PCI Expansion Board Pinout—Universal Board

Pin	Side B	Side A	Pin	Side B	Side A
51	Keyway	Keyway	76	Ground	AD[52]
52	AD[08]	C/BE[0]#	77	AD[51]	AD[50]
53	AD[07]	+3.3V	78	AD[49]	Ground
54	+3.3V	AD[06]#	79	+VI/O	AD[48]
55	AD[05]	AD[04]#	80	AD[47]	AD[46]
56	AD[03]	Ground	81	AD[45]	Ground
57	Ground	AD[02]	82	Ground	AD[44]
58	AD[01]	AD[00]	83	AD[43]	AD[42]
59	+VI/O	+VI/O	84	AD[41]	+VI/O
60	ACK64#	REQ64#	85	Ground	AD[40]
61	+5V	+5V	86	AD[39]	AD[38]
62	+5V	+5V	87	AD[37]	Ground
	Keyway	Keyway	88	+VI/O	AD[36]
	Keyway	Keyway	89	AD[35]	AD[34]
63	Reserved	Ground	90	AD[33]	Ground
64	Ground	C/BE[7]#	91	Ground	AD[32]
65	C/BE[6]#	C/BE[5]#	92	Reserved	Reserved
66	C/BE[4]#	+VI/O	93	Reserved	Ground
67	Ground	PAR64	94	Ground	Reserved
68	AD[63]	AD[62]			
69	AD[61]	Ground			
70	+VI/O	AD[60]			
71	AD[59]	AD[58]			
72	AD[57]	Ground			
73	Ground	AD[56]			
74	AD[55]	AD[54]			
75	AD[53]	+VI/O			