



---

# NFS Server Performance and Tuning Guide for Sun Hardware

---

Sun Microsystems, Inc.  
901 San Antonio Road  
Palo Alto, CA 94303-4900  
U.S.A

Part No.: 805-4448  
September 1998, Revision A

Send comments about this document to:  
[docfeedback@sun.com](mailto:docfeedback@sun.com)

1998 Sun Microsystems, Inc., 901 San Antonio Road, Palo Alto, California 94303-4900 U.S.A.

This product or document is protected by copyright and distributed under licenses restricting its use, copying, distribution, and decompilation. No part of this product or document may be reproduced in any form by any means without prior written authorization of Sun and its licensors, if any. Third-party software, including font technology, is copyrighted and licensed from Sun suppliers.

Parts of the product may be derived from Berkeley BSD systems, licensed from the University of California. UNIX is a registered trademark in the U.S. and other countries, exclusively licensed through X/Open Company, Ltd.

Sun, Sun Microsystems, the Sun logo, SunSoft, SunDocs, SunExpress, NFS, SPARCcenter, SPARCserver, Netra, Sun Enterprise, SunDocs, Sun StorEdge, SmartServe, Solstice SyMON, UltraSPARC, Gigaplane, SuperSPARC, MultiPack, Volume Manager, DiskSuite, UniPack, and Solaris are trademarks, registered trademarks, or service marks of Sun Microsystems, Inc. in the U.S. and other countries. All SPARC trademarks are used under license and are trademarks or registered trademarks of SPARC International, Inc. in the U.S. and other countries. Products bearing SPARC trademarks are based upon an architecture developed by Sun Microsystems, Inc.

The OPEN LOOK and Sun™ Graphical User Interface was developed by Sun Microsystems, Inc. for its users and licensees. Sun acknowledges the pioneering efforts of Xerox in researching and developing the concept of visual or graphical user interfaces for the computer industry. Sun holds a non-exclusive license from Xerox to the Xerox Graphical User Interface, which license also covers Sun's licensees who implement OPEN LOOK GUIs and otherwise comply with Sun's written license agreements.

RESTRICTED RIGHTS: Use, duplication, or disclosure by the U.S. Government is subject to restrictions of FAR 52.227-14(g)(2)(6/87) and FAR 52.227-19(6/87), or DFAR 252.227-7015(b)(6/95) and DFAR 227.7202-3(a).

DOCUMENTATION IS PROVIDED "AS IS" AND ALL EXPRESS OR IMPLIED CONDITIONS, REPRESENTATIONS AND WARRANTIES, INCLUDING ANY IMPLIED WARRANTY OF MERCHANTABILITY, FITNESS FOR A PARTICULAR PURPOSE OR NON-INFRINGEMENT, ARE DISCLAIMED, EXCEPT TO THE EXTENT THAT SUCH DISCLAIMERS ARE HELD TO BE LEGALLY INVALID.

Copyright 1998 Sun Microsystems, Inc., 901 San Antonio Road, Palo Alto, Californie 94303 Etats-Unis. Tous droits réservés.

Ce produit ou document est protégé par un copyright et distribué avec des licences qui en restreignent l'utilisation, la copie, la distribution, et la décompilation. Aucune partie de ce produit ou document ne peut être reproduite sous aucune forme, par quelque moyen que ce soit, sans l'autorisation préalable et écrite de Sun et de ses bailleurs de licence, s'il y en a. Le logiciel détenu par des tiers, et qui comprend la technologie relative aux polices de caractères, est protégé par un copyright et licencié par des fournisseurs de Sun.

Des parties de ce produit pourront être dérivées des systèmes Berkeley BSD licenciés par l'Université de Californie. UNIX est une marque déposée aux Etats-Unis et dans d'autres pays et licenciée exclusivement par X/Open Company, Ltd.

Sun, Sun Microsystems, le logo Sun, SunSoft, SunDocs, SunExpress, NFS, SPARCcenter, SPARCserver, Netra, Sun Enterprise, SunDocs, Sun StorEdge, SmartServe, Solstice SyMON, UltraSPARC, Gigaplane, SuperSPARC, MultiPack, Volume Manager, DiskSuite, UniPack, et Solaris sont des marques de fabrique ou des marques déposées, ou marques de service, de Sun Microsystems, Inc. aux Etats-Unis et dans d'autres pays. Toutes les marques SPARC sont utilisées sous licence et sont des marques de fabrique ou des marques déposées de SPARC International, Inc. aux Etats-Unis et dans d'autres pays. Les produits portant les marques SPARC sont basés sur une architecture développée par Sun Microsystems, Inc.

L'interface d'utilisation graphique OPEN LOOK et Sun™ a été développée par Sun Microsystems, Inc. pour ses utilisateurs et licenciés. Sun reconnaît les efforts de pionniers de Xerox pour la recherche et le développement du concept des interfaces d'utilisation visuelle ou graphique pour l'industrie de l'informatique. Sun détient une licence non exclusive de Xerox sur l'interface d'utilisation graphique Xerox, cette licence couvrant également les licenciés de Sun qui mettent en place l'interface d'utilisation graphique OPEN LOOK et qui en outre se conforment aux licences écrites de Sun.

CETTE PUBLICATION EST FOURNIE "EN L'ETAT" ET AUCUNE GARANTIE, EXPRESSE OU IMPLICITE, N'EST ACCORDEE, Y COMPRIS DES GARANTIES CONCERNANT LA VALEUR MARCHANDE, L'APTITUDE DE LA PUBLICATION A REPENDRE A UNE UTILISATION PARTICULIERE, OU LE FAIT QU'ELLE NE SOIT PAS CONTREFAISANTE DE PRODUIT DE TIERS. CE DENI DE GARANTIE NE S'APPLIQUERAIT PAS, DANS LA MESURE OU IL SERAIT TENU JURIDIQUEMENT NUL ET NON AVENU.



Please  
Recycle



Adobe PostScript

# Contents

---

<b>Preface</b>	<b>xiii</b>
<b>1. NFS Overview</b>	<b>1</b>
NFS Characteristics	1
NFS Version 2 and Version 3	2
NFS Version 3 Features and Operations	2
Changes in Version 3 from Version 2	4
64-Bit File Size	4
Asynchronous Writes	5
Read Directory With Attributes	5
Weak Cache Consistency	5
Tuning Cycle	6
Third Party Tools	7
<b>2. Hardware Overview</b>	<b>9</b>
NFS File Servers	9
Dedicated NFS Servers	13
Netra NFS Server System	13
Enterprise Servers	15
Sun Enterprise 4000, 5000, and 6000 Systems	15

Sun Enterprise 3500, 4500, 5500, and 6500 Systems	17
SPARCcenter 2000 and SPARCcenter 2000E Systems	19
Workgroup Servers	20
Sun Enterprise 150 Server System	21
Sun Enterprise 250 System	22
Sun Enterprise 450 System	24
Sun Enterprise 1 and 2 Systems	25
SPARCserver 20 System	26
SPARCserver 20 System Features	27
Disk Expansion Units	28
SPARCstorage Array Subsystem	28
Sun StorEdge A1000 RAID Disk Array	30
Sun StorEdge A3000 Subsystem	31
Sun StorEdge A5000 Subsystem	33
Sun StorEdge A7000 Intelligent Storage Server	34
Sun StorEdge MultiPack	34
Sun StorEdge UniPack	35
<b>3. Analyzing NFS Performance</b>	<b>37</b>
Tuning the NFS Server	37
Optimizing Performance	37
Resolving Performance Problems	38
Checking Network, Server, and Client Performance	38
▼ To Check the Network	39
Checking the NFS Server	42
▼ To Check the NFS Server	42
Checking Each Client	56
▼ To Check Each Client	56

<b>4. Configuring the Server and the Client to Maximize NFS Performance</b>	<b>61</b>
Tuning to Improve NFS Performance	61
▼ To Monitor and Tune Server Performance	62
Balancing NFS Server Workload	62
Networking Requirements	62
Data-Intensive Applications	63
Configuring the Network When the Primary Application of Your Server Is Data-Intensive	63
Attribute-Intensive Applications	64
Systems with More Than One Class of Users	64
Disk Drives	65
Determining if Disks Are the Bottleneck	65
Limiting Disk Bottlenecks	65
Replicating File Systems	66
Adding the Cache File System	67
Configuration Rules for Disk Drives	69
Using Solstice DiskSuite or Online: DiskSuite to Spread Disk Access Load	70
Using Log-Based File Systems With Solstice DiskSuite or Online: DiskSuite 3.0	71
Using the Optimum Zones of the Disk	71
Central Processor Units	72
Determining CPU Usage	72
Memory	73
Determining if an NFS Server Is Memory Bound	74
▼ To Determine if the Server Is Memory Bound	74
Calculating Memory	75
General Memory Rules	75
Specific Memory Rules	75

Swap Space	76
▼ To Set Up Swap Space	76
Prestoserve NFS Accelerator	76
NVRAM-NVSIMM	77
NVRAM SBus	77
Tuning Parameters	78
Setting the Number of NFS Threads in <code>/etc/init.d/nfs.server</code>	78
Identifying Buffer Sizes and Tuning Variables	79
Using <code>/etc/system</code> to Modify Kernel Variables	79
Adjusting Cache Size: <code>maxusers</code>	80
Parameters Derived From <code>maxusers</code>	80
Adjusting the Buffer Cache ( <code>bufhwm</code> )	80
Directory Name Lookup Cache (DNLC)	82
▼ To Reset <code>ncsize</code>	82
Increasing the Inode Cache	83
Increasing the Inode Cache in the Solaris 2.4 or the 2.5 Operating Environments	83
Increasing Read Throughput	84
▼ To Increase the Number of Read-Aheads With Version 2	85
▼ To Increase the Number of Read-Aheads With Version 3	85
<b>5. Troubleshooting</b>	<b>87</b>
Troubleshooting Tools	87
General Troubleshooting Tuning Tips	87
Client Bottlenecks	89
Server Bottlenecks	90
Network Bottlenecks	91
<b>A. Using NFS Performance-Monitoring and Benchmarking Tools</b>	<b>93</b>

NFS Monitoring Tools	94
Network Monitoring Tools	95
SPEC System File Server 2.0	98





# Figures

---

- FIGURE 1-1 Overview of the Tuning Cycle 6
- FIGURE 2-1 Environments Supported by the Netra NFS Server 14
- FIGURE 2-2 Sun Enterprise 6000 and 5000 Server Cabinet System and Sun Enterprise 4000 Stand-alone System 16
- FIGURE 2-3 Front View of the Sun Enterprise 6500, 5500, and 4500 Servers 19
- FIGURE 2-4 Sun Enterprise 150 Front View 22
- FIGURE 2-5 Sun Enterprise 250 Front View 23
- FIGURE 2-6 Front View of the Sun Enterprise 450 Server 25
- FIGURE 2-7 Sun Enterprise 1 Front View 26
- FIGURE 2-8 SPARCserver 20 System Front View 27
- FIGURE 2-9 Front View of the SPARCstorage Array Subsystem 29
- FIGURE 2-10 SPARCstorage Array Subsystem Installation Options 29
- FIGURE 2-11 Sun StorEdge A1000 Front View of a Twelve Drive System 31
- FIGURE 2-12 Front View of the Sun StorEdge A3000 Subsystem 32
- FIGURE 2-13 Front View of the Sun StorEdge A5000 Subsystem 33
- FIGURE 2-14 Front View of the Sun StorEdge MultiPack 35
- FIGURE 2-15 Sun StorEdge UniPack 35
- FIGURE 3-1 Flow Diagram for Checking the Network Performance 39
- FIGURE 3-2 Flow Diagram of Possible Responses to the `ping -sRv` Command 42



# Tables

---

TABLE 1-1	NFS Operations in Version 2 and Version 3	3
TABLE 1-2	New NFS Operations in Version 3	3
TABLE 2-1	NFS Server Comparison Table	10
TABLE 3-1	<code>netstat -i 15</code> Command Arguments	39
TABLE 3-2	Arguments to the <code>ping -sRv</code> Command	41
TABLE 3-3	Output of the <code>iostat -x 15</code> Command (Extended Disk Statistics)	47
TABLE 3-4	Options to the <code>iostat -xc 15   d2fs.server</code> Command	48
TABLE 3-5	Output for the <code>iostat -xc 15</code> Command	49
TABLE 3-6	Output of the <code>sar -d 15 1000   d2fs.server</code> Command	51
TABLE 3-7	Description of the Output of the <code>nfsstat -s</code> Command	53
TABLE 3-8	Description of the <code>nfsstat -s</code> Command Output	54
TABLE 3-9	Output of the <code>nfsstat -c</code> Command	57
TABLE 3-10	Description of the <code>nfsstat -c</code> Command Output	57
TABLE 3-11	Description of the Output of the <code>nfsstat -m</code> Command	58
TABLE 3-12	Results of the <code>nfsstat -m</code> Command	59
TABLE 4-1	Statistical Information Supplied by the <code>cachefsstat</code> Command	68
TABLE 4-2	Output of the <code>mpstat</code> Command	72
TABLE 4-3	Guidelines for Configuring CPUs in NFS Servers	73
TABLE 4-4	Swap Space Requirements	76

TABLE 4-5	Default Settings for Inode and Name Cache Parameters	80
TABLE 4-6	Descriptions of the Arguments to the <code>sar</code> Command	81
TABLE 5-1	General Troubleshooting Tuning Problems and Actions to Perform	87
TABLE 5-2	Client Bottlenecks	89
TABLE 5-3	Server Bottlenecks	90
TABLE 5-4	Network-Related Bottlenecks	91
TABLE A-1	NFS Operations and Performance-Monitoring Tools	94
TABLE A-2	Network Monitoring Tools	95
TABLE A-3	Arguments to the <code>snoop</code> Command	97
TABLE A-4	Description of Arguments to the <code>snoop -i pkts -v 101</code> Command	97
TABLE A-5	Arguments to the <code>snoop -i pkts rpc nfs</code> and <code>sunroof</code> and <code>boutique</code> Command	98
TABLE A-6	Description of Arguments to the <code>snoop -i pkts -o.nfs rpc nfs sunroof boutique</code> Command	98
TABLE A-7	NFS Operations Mix by Call	100
TABLE A-8	SPEC SFS 2.0 Results With Version 2	101
TABLE A-9	SPEC SFS 2.0 Results With Version 3	101

# Preface

---

The *SMCC NFS Server Performance and Tuning Guide* is about the NFS™ distributed computing file system. It describes:

- NFS and network performance analysis and tuning
- NFS and network monitoring tools

This book is written with these assumptions about your server:

- It runs the Solaris™ 2.4, 2.5, 2.5.1, 2.6, or 7 operating environment.
- It is set up in a networked configuration.
- It is a SPARCserver™ system, SPARCcenter™ 2000(E), Netra™ NFS 150 Server, or a Sun™ Enterprise™ 3x00, 4x00, 5x00, or 6x00 system.

This book is for system administrators and network specialists who configure, analyze performance, or tune servers that provide the NFS service to network clients. It discusses NFS version 2 and version 3 tuning for the Solaris 2.4, 2.5, 2.5.1, 2.6, and 7 operating environments.

---

# Typographic Conventions

TABLE P-1 Typographic Conventions

Typeface or Symbol	Meaning	Examples
AaBbCc123	The names of commands, files, and directories; on-screen computer output.	Edit your <code>.login</code> file. Use <code>ls -a</code> to list all files. % You have mail.
AaBbCc123	What you type, when contrasted with on-screen computer output.	% <b>su</b> Password:
<i>AaBbCc123</i>	Book titles, new words or terms, words to be emphasized. Command-line variable; replace with a real name or value.	Read Chapter 6 in the <i>User's Guide</i> . These are called <i>class</i> options. You <i>must</i> be <code>root</code> to do this. To delete a file, type <code>rm filename</code> .

---

# Shell Prompts

TABLE P-2 Shell Prompts

Shell	Prompt
C shell	<i>machine_name%</i>
C shell superuser	<i>machine_name#</i>
Bourne shell and Korn shell	\$
Bourne shell and Korn shell superuser	#

---

## Sun Documentation on the Web

The `docs.sun.com` web site enables you to access Sun technical documentation on the Web. You can browse the `docs.sun.com` archive or search for a specific book title or subject at:

`http://docs.sun.com`

---

## Sun Welcomes Your Comments

We are interested in improving our documentation and welcome your comments and suggestions. You can email your comments to us at `docfeedback@sun.com`.

Please include the part number of your document in the subject line of your email.





# NFS Overview

---

This chapter briefly discusses NFS characteristics, the tuning cycle, and third-party tools used to monitor NFS activity.

---

## NFS Characteristics

The NFS environment provides transparent file access to remote files over a network. File systems of remote devices appear to be local. Clients access remote file systems by using either the `mount` command or the automounter.

The NFS protocol enables multiple client retries and easy crash recovery. The client provides all of the information for the server to perform the requested operation. The client retries the request until it is acknowledged by the server, or until it times out. The server acknowledges writes when the data is flushed to nonvolatile storage.

The multithreaded kernel does not require the maintenance of multiple `nfsd` or asynchronous-block I/O daemon (`biod`) processes; they are both implemented as operating system kernel threads. There are no `biods` on the client and one `nfsd` process exists on the server.

NFS traffic is characterized by its random patterns. NFS requests, which are usually of many types, are generated in bursts. The capacity of an NFS server must address the bursty nature of NFS file service demands. Demand varies widely but is relatively predictable during normal activity.

Most requests from applications (which may be local or remote), follow this pattern:

1. The user reads in the sections of the application binary then executes the code pages leading to a user dialog, which specifies a data set on which to operate.
2. The application reads the data set from the remote disk.

3. The user can then interact with the application, manipulating the in-memory representation of the data. This phase continues for most of the runtime of the application.
4. The modified data set is saved to disk.

More sections of the application binary may be paged in as the application continues to run.

---

## NFS Version 2 and Version 3

The Solaris 2.5 through Solaris 7 operating environments are shipped with NFS Version 2 and NFS version 3. NFS version 3 is a new addition to the Solaris operating environments beginning with Solaris 2.5.

The NFS client negotiates with the server regarding whether to use NFS version 2 or NFS version 3. If the server supports NFS version 3, then version 3 becomes the default to use. You can override the default NFS version used with the `vers=` mount option.

You tune NFS version 2 and NFS version 3 similarly.

## NFS Version 3 Features and Operations

NFS version 3 contains several features to improve performance, reduce server load, and reduce network traffic. Since NFS version 3 is faster for I/O writes, and uses fewer operations over the network, you will have more efficient use of the network. Note that higher throughput may make the network busier.

NFS version 3 maintains the stateless server design and simple crash recovery of version 2 along with its approach to build a distributed file service from cooperating protocols.

TABLE 1-1 describes the NFS operations and their functions for versions 2 and 3. TABLE 1-2 lists the NFS operations new to Version 3.

**TABLE 1-1 NFS Operations in Version 2 and Version 3**

<b>Operation</b>	<b>Function in Version 2</b>	<b>Change in Version 3</b>
create	Creates a file system node; may be a file or a symbolic link	No change
statfs	Gets dynamic file system information	Replaced by <code>fsstat</code>
getattr	Gets file or directory attributes such as file type, size, permissions, and access times	No change
link	Creates a hard link in the remote file system	No change
lookup	Searches directory for file and return file handle	No change
mkdir	Creates a directory	No change
null	Does nothing; used for testing and timing of server response	No change
read	Reads an 8-Kbyte block of data (32-KByte blocks). This can be raised beyond 64 KBytes for TCP.	Block of data up to 4 Gbytes
readdir	Reads a directory entry	No change
readlink	Follows a symbolic link on the server	No change
rename	Changes the directory name entry	No change
remove	Removes a file system node	No change
rmdir	Removes a directory	No change
root	Retrieves the root of the remote file system (not presently used)	Removed
setattr	Changes file or directory attributes	No change
symlink	Makes a symbolic link in a remote file system	No change
wrcache	Writes an 8 Kbyte block of data to the remote cache (not presently used)	Removed
write	Writes an 8 Kbyte block of data (32-KByte blocks). This can be raised beyond 64 KBytes for TCP.	Block of data up to 4 Gbytes

**TABLE 1-2 New NFS Operations in Version 3**

<b>Operation in Version 3</b>	<b>Function</b>
<code>access</code>	Check access permission
<code>mknod</code>	Create a special device
<code>readdir</code>	Read from directory

**TABLE 1-2** New NFS Operations in Version 3

Operation in Version 3	Function
<code>readdirplus</code>	Extended read from directory
<code>fsinfo</code>	Get static file system information
<code>pathconf</code>	Retrieve POSIX information
<code>commit</code>	Commit cached data on a server to stable storage

## Changes in Version 3 from Version 2

The `root` and `writetocache` operations have been removed. A `mknod` operation has been defined to allow the creation of special files, thus eliminating the overloading of `create`. Caching on the client is not defined nor dictated by Version 3. Additional information and hints have been added to Version 3 to allow clients that implement caching to manage their caches more effectively.

Operations that affect the attributes of a file or directory may now return the new attributes after the operation has completed to optimize out a subsequent `getattr` used in validating attribute caches. Also, operations that modify the directory in which the target object resides return the old and new attributes of the directory to allow clients to implement more intelligent cache invalidation procedures.

The `access` operation provides access permission checking on the server. The `fsstat` operation returns static information about a file system and server. The `readdirplus` operation returns file handles and attributes in addition to directory entries. The `pathconf` operation returns POSIX `pathconf` information about a file.

## 64-Bit File Size

Version 3 of the NFS protocol enables access to files whose length fits in 64 bits. With version 2, the length had to fit in 32 bits (4 Gbytes).

Access to large files (64-bit) is possible only if the client, server, and the operating system support large files. If the client implementation is limited to 32-bit files, then the client can't access files larger than 32 bits (even if the server supports them). Conversely, if the client supports 64-bit files but the server only supports 32-bit files, the client is limited to 32-bit files. The Solaris 7 operating environment is the first Solaris release that takes advantage of this protocol feature. Operating environments prior to Solaris 7 did *not* have 64-bit file support.

The limit for the UNIX File System in the Solaris 2.6 and 7 operating environments is 1 Terrabyte (40 bits).

## Asynchronous Writes

NFS version 3 can use asynchronous writes, which is optional. The NFS version 3 client sends asynchronous write requests to the server, which acknowledges receiving the data. However, the server is not required to write the data to stable storage before replying. The server may schedule the write, or wait to gather multiple write requests together.

The client maintains a copy of the data in case the server is unable to complete the writes. When the client wants to free its copy, it notifies the server with a `COMMIT` operation. The server responds positively only after it ensures that the data is written to stable storage. Otherwise, it responds with an error and the client resends the data synchronously.

Asynchronous writes enable the server to determine the best policy to synchronize the data. The data is most likely synchronized by the time the `COMMIT` arrives. Compared with NFS version 2, this scheme enables better buffering and more parallelism.

With NFS version 2, the server does not respond to a write request until the data is placed in stable storage. However, it may use techniques such as write gathering to issue multiple concurrent requests before responding to any of the requests.

## Read Directory With Attributes

NFS version 3 contains an operation called `REaddirPLUS`. Most `REaddir`s are now issued as `REaddirPLUS` calls; for example, an `ls` or an `ls -l` triggers `REaddirPLUS` calls. When the `ls -l` commands run over version 3, the file handles and attributes are returned with the list of names in the directory. In version 2, the names are returned first, then additional calls to the server are required to obtain the file handles and attributes.

The advantage of the `REaddirPLUS` operation in version 3 is that an `ls` and an `ls -l` are now comparable in speed because separate `GETATTR` requests are not required for each file.

## Weak Cache Consistency

Many NFS version 2 clients cache file and directory data to improve performance. At times, the version 2 method fails when multiple clients are sharing and caching the same data.

Weak cache consistency enables the client to detect data changes between its last access and the current request. This is done when the server sends back the previous attributes with the response. The client can then compare the previous attributes with what it thought the previous attributes were and detect the changes.

---

# Tuning Cycle

FIGURE 1-1 shows a flowchart of the tuning cycle:

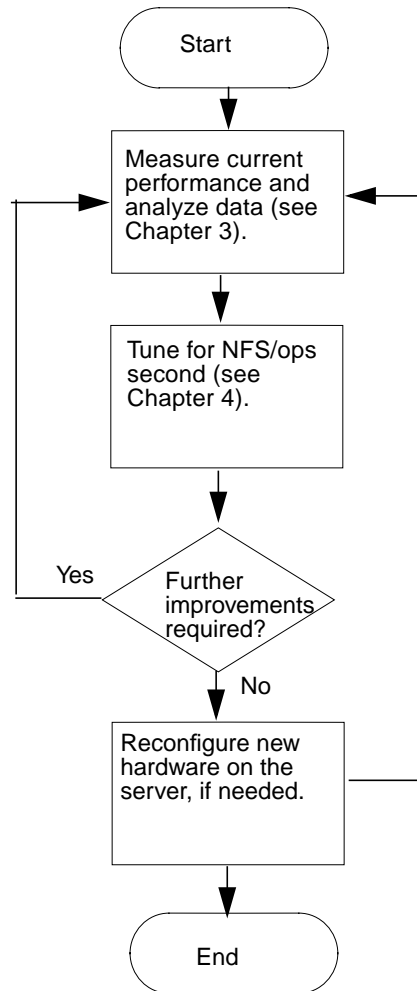

FIGURE 1-1 Overview of the Tuning Cycle

---

# Third Party Tools

Some of the third party tools you can use for NFS and networks include:

- NetMetrix (Hewlett-Packard)
- SharpShooter (Network General Corporation, formerly AIM Technology)

SharpShooter (version 3) understands the NFS version 3 protocol.





## Hardware Overview

---

This chapter provides an overview of the following NFS servers and expansion units:

- Sun Enterprise 1 system
- Sun Enterprise 2 system
- SPARCserver 20 system
- Sun Enterprise 150 system
- Sun Enterprise 250 system
- Sun Enterprise 450 system
- Sun Enterprise 4000, 5000, and 6000 systems
- Sun Enterprise 3500, 4500, 5500, and 6500 systems
- SPARCserver 1000 or SPARCserver 1000E system
- SPARCcenter 2000 or SPARCserver 2000E system
- Netra NFS Server system
- SPARCstorage Array subsystem
- Sun StorEdge™ A1000 RAID Disk Array
- Sun StorEdge A3000 subsystem
- Sun StorEdge A5000 subsystem
- Sun StorEdge A7000 Intelligent Storage Server
- SPARCstorage MultiPack enclosure
- SPARCstorage UniPack enclosure

---

## NFS File Servers

This section provides a hardware overview of Sun NFS servers. TABLE 2-1 illustrates the conditions under which a particular NFS file server will meet your needs. This table is arranged by first presenting the Netra NFS Server, a dedicated NFS server. Next, the table presents high capacity enterprise servers followed by workgroup

servers. Workgroup servers are dedicated to a group, department, or small organization that shares common resources or tasks. Workgroup servers usually provide a specific function such as an NFS file server.

**TABLE 2-1** NFS Server Comparison Table

Server	Maximum Specifications	Positioning	Key Advantages
Netra NFS Server	<ul style="list-style-type: none"> <li>—100 NFS clients</li> <li>—24 Gbytes of internal disk storage (48 Gbytes with 4 Gbyte disk drives)</li> <li>—2 subnets with Fast Ethernet (100 BaseT), Token Ring, FDDI</li> <li>—9 subnets with 10BaseT Ethernet</li> </ul>	Dedicated NFS server supporting both workgroup and department needs	<ul style="list-style-type: none"> <li>Industry leading NFS price/performance with RAID 5;</li> <li>Fast response times; easy to administer with HTML user interface;</li> <li>highly reliable with internal UPS and RAID 5;</li> <li>includes PC-NFS server software;</li> <li>exclusively supports NFS applications;</li> <li>RAID 5 and single file system is preconfigured</li> </ul>
Sun Enterprise 6000	<ul style="list-style-type: none"> <li>—At least 600 NFS clients</li> <li>—189 Gbytes of disk storage (system enclosure only)</li> <li>—More than 20 subnets per system</li> <li>—Ethernet, optional FDDI, SunATM, and Token Ring</li> </ul>	Most scalable and expandable Sun server	<ul style="list-style-type: none"> <li>Handles a minimum of 14,000 ops/second, which is equivalent to 140,000 PC clients; handles arbitrary NFS client loads</li> </ul>
Sun Enterprise 5000	<ul style="list-style-type: none"> <li>—At least 400 NFS clients</li> <li>—233 Gbytes of disk storage (system enclosure only)</li> <li>—More than 20 subnets per system</li> <li>—Ethernet, optional FDDI, SunATM, and Token Ring</li> </ul>	Data center server system	<ul style="list-style-type: none"> <li>Delivers high performance and high availability for enterprise wide applications supporting thousands of users; able to handle arbitrary NFS client loads</li> </ul>
Sun Enterprise 4000	<ul style="list-style-type: none"> <li>—At least 400 NFS clients</li> <li>—168 Gbytes of disk storage (system enclosure only)</li> <li>—More than 20 subnets per system</li> <li>—Ethernet, optional FDDI, SunATM, and Token Ring</li> </ul>	Compact yet highly expandable system	<ul style="list-style-type: none"> <li>Delivers high performance scalability for department applications in a distributed network computing environment; handles arbitrary NFS client loads</li> </ul>

**TABLE 2-1 NFS Server Comparison Table (Continued)**

Server	Maximum Specifications	Positioning	Key Advantages
Sun Enterprise 3000	<ul style="list-style-type: none"> <li>—At least 300 NFS clients</li> <li>—42 Gbytes of disk storage (system enclosure only)</li> <li>—More than 20 subnets per system</li> <li>— Ethernet, optional FDDI, SunATM, and Token Ring</li> </ul>	Affordable departmental server	Applications support up to hundreds of users in an office environments; handles arbitrary NFS client loads
Sun Enterprise 6500	<ul style="list-style-type: none"> <li>—382 Gbytes internal storage (system cabinet only)</li> <li>—Greater than 10 Terabytes of total disk storage</li> <li>—30 CPUs and 30 Gbytes of memory</li> </ul>	High end datacenter server	Handles arbitrary NFS client loads; Dynamic Reconfiguration, Alternate Pathing, and CPU power control
Sun Enterprise 5500	<ul style="list-style-type: none"> <li>—509 Gbytes of internal storage (system cabinet only)</li> <li>—Greater than 6 Terabytes of maximum disk storage</li> <li>—14 CPUs and 14 Gbytes of memory</li> </ul>	Entry level datacenter server	Handles arbitrary NFS client loads; Dynamic Reconfiguration, Alternate Pathing, and CPU power control
Sun Enterprise 4500	<ul style="list-style-type: none"> <li>—33.6 Gbytes of internal storage (system only)</li> <li>—Greater than 4 Terabytes of total disk storage</li> <li>—14 CPUs and 14 Gbytes of memory</li> </ul>	High end departmental server	Handles arbitrary NFS client loads; Dynamic Reconfiguration, Alternate Pathing, and CPU power control
Sun Enterprise 3500	<ul style="list-style-type: none"> <li>—72.8 Gbytes of internal storage (system only)</li> <li>—Greater than 2 Terabytes of total disk storage</li> <li>—8 CPUs and up to 8 Gbytes of memory</li> </ul>	Entry level departmental server	Handles arbitrary NFS client loads; Dynamic Reconfiguration, Alternate Pathing, and CPU power control
SPARCcenter 2000 or 2000E	<ul style="list-style-type: none"> <li>—500 NFS clients</li> <li>—36 subnets</li> <li>—731 Gbytes of storage</li> <li>—Ethernet, FDDI, SunATM, and Token Ring</li> </ul>	Highest capacity; multipurpose enterprise server (the total solution for an entire company)	Centralized administration maximum headroom for growth; multiprocessor, I/O, and network performance scalability

**TABLE 2-1** NFS Server Comparison Table *(Continued)*

<b>Server</b>	<b>Maximum Specifications</b>	<b>Positioning</b>	<b>Key Advantages</b>
SPARCserver 1000 or 1000E	—300 NFS clients —12 subnets —395 Gbytes of storage —Ethernet, FDDI, SunATM, and Token Ring	High capacity multipurpose workgroup server	Excellent capacity performance; multipurpose server (NFS, compute, database), affordable, scalable, integrated packaging
Sun Enterprise 450	—Used in environments that require large amounts of disk storage with fast or multiple I/O channels to clients or to the network	Mid-range server	Supports RAID 1 (disk mirroring), RAID 3 (striping data and parity across drive groups), and RAID 5 (hot spares for FC-AL disks)
Sun Enterprise 250 Server	—Up to 54 Gbytes of disk storage, dual CPU processor, and fast PCI I/O channels	Mid-range server	Supports RAID 0 (disk striping), RAID 1 (disk mirroring), and RAID 5 (hot spares); automated hardware failure notification; hot sparing support
Sun Enterprise 150 Server	—Internal disk array with up to twelve hot-plugable disks providing 48 Gbytes of disk capacity (based on 4 Gbyte disks)	High end workgroup server	Supports RAID 0 (disk striping) RAID 1 (disk mirroring) and RAID 5 (hot spares); high level of I/O throughput and capacity; significant expansion capabilities; advanced I/O and networking

TABLE 2-1 NFS Server Comparison Table (Continued)

Server	Maximum Specifications	Positioning	Key Advantages
Sun Enterprise 2	<ul style="list-style-type: none"> <li>—At least 350-400 NFS clients</li> <li>—67 Gbytes of disk storage (4 Gbytes in the system and 63 Gbytes in the SPARCstorage Array)</li> <li>—4 subnets</li> <li>—Ethernet, optional FDDI and SunATM</li> </ul>	High performance multiprocessing server for mid to large size workgroups	High throughput for multiprocessing; high application performance; efficient design and process handling
Sun Enterprise 1	<ul style="list-style-type: none"> <li>—200-220 NFS clients</li> <li>—147 Gbytes of storage</li> <li>— 4 subnets</li> <li>—Ethernet, optional FDDI and SunATM</li> </ul>	High capacity; medium to large workgroup server (50 to 100 users)	Excellent performing uniprocessor workgroup server that simplifies administration and lowers costs
SPARCserver 20	<ul style="list-style-type: none"> <li>—125 NFS clients</li> <li>—138 Gbytes of storage</li> <li>—4 subnets</li> <li>—Ethernet, FDDI, SunATM, and Token Ring</li> </ul>	Low cost; multipurpose workgroup server PC LAN server	Low cost, powerful, flexible, and easily redeployed

## Dedicated NFS Servers

This section presents an overview of the Netra NFS Server system.

### Netra NFS Server System

The Netra NFS Server system provides an easily managed, highly reliable, highly tuned dedicated NFS server. It is built exclusively to support NFS applications; Solaris software environment applications are not supported. This Netra NFS server provides superior NFS operations performance over general purpose servers.

The key benefits of this Netra NFS server include:

- Easy installation (preconfigured system)
- Easy HTML management interface with the LCD system status and input panel
- Factory preconfigured RAID-5 disks
- Dedicated, simplified operation set
- Tuned for NFS performance
- System reliability (UPS for graceful shutdown on power failure)
- Uninterruptable power supply

This server meets the demands of high speed network environments. Because this server delivers high performance for NFS operations, it is most often installed in departments and workgroups where data access requirements are high and other servers are available for running applications and system management software (see FIGURE 2-1).

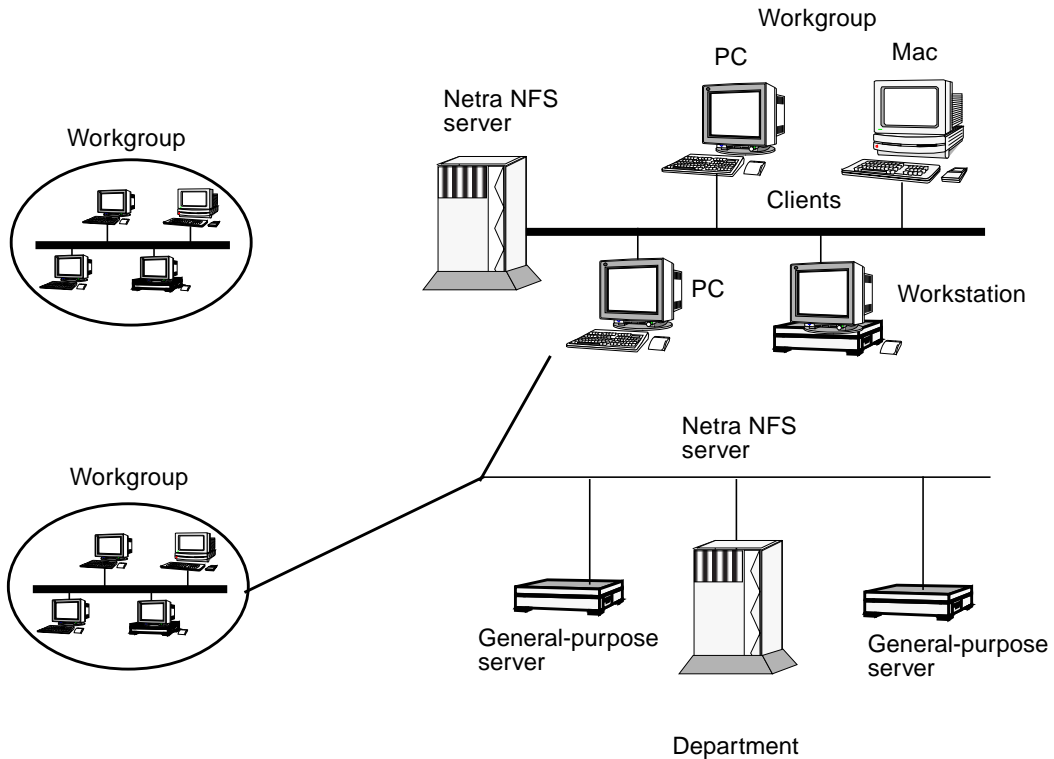

**FIGURE 2-1** Environments Supported by the Netra NFS Server

As FIGURE 2-1 shows, the Netra NFS Server system supports both workgroup and department needs.

### *Netra NFSServer Software Support*

The easy to use customized Netra NFS SmartServe™ software, which is focused exclusively on NFS applications, is tuned for NFS performance and is easy to administer. The software has the following features:

- Modified Solaris operating environment (dedicated and optimized for NFS)

- SNMP agent
- Single file system and RAID 5 preconfigured
- Backup software for online backups
- Support for NFS Version 2 and NFS Version 3
- Disk management support (RAID level 5 for storage management)
- Failure management and recovery
- System performance tuning (stable memory and NFS Smart Cache)
- PCNFSD (to use with NFS on PCs)

### *Netra NFS Server Hardware Overview*

This server is based on the Ultra 1 processor board, which is designed to deliver balanced system performance. With twelve slots of data disks, the data disk capacity of this server is 24 Gbytes (48 Gbytes with 4 Gbyte disk drives). The disk drives are hot pluggable. A 10BaseT Ethernet controller is built onboard.

One of the three SBus slots are used for ISP controllers. The second SBus slot contains a 100BaseT network card. The third SBus slot is available for additional network interfaces.

This system comes in two options: tower and rack-ready. Four rack-ready systems can be installed in standard Sun racks. The system also has a standard 3.5-inch diskette drive and a 644 Mbyte capacity CD-ROM drive. The eight SIMM slots can store up to 512 Mbytes of RAM.

## Enterprise Servers

Sun has a range of enterprise servers. This section discusses the following enterprise servers:

- Sun Enterprise 4x00, 5x00, and 6x00 servers
- SPARCcenter 2000/2000E servers
- SPARCserver 1000/1000E servers

### Sun Enterprise 4000, 5000, and 6000 Systems

The Sun Enterprise 6000 server system, the Sun Enterprise 5000 server system and the Sun Enterprise 4000 server system are available in two enclosures (see FIGURE 2-2):

- Enterprise 6000 or 5000 is a 56-inch cabinet containing either a 16-slot or 8-slot card cage.
- Enterprise 4000 is a stand-alone enclosure containing an 8-slot card cage.

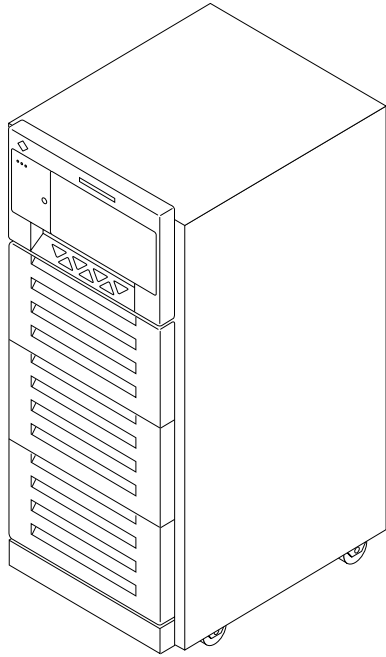

Sun Enterprise 6000/5000 are  
16-slot or 8-slot cabinet servers

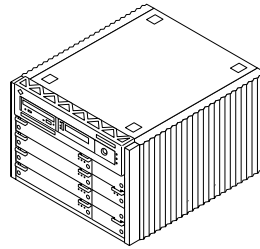

Sun Enterprise 4000 is an  
8-slot stand-alone server

**FIGURE 2-2** Sun Enterprise 6000 and 5000 Server Cabinet System and Sun Enterprise 4000 Stand-alone System

The same CPU/memory board, I/O boards, disk board, processor modules, memory SIMMs, power modules, and cooling modules are used in all enclosures.

The minimum configuration for the Sun Enterprise 4000, 5000, and 6000 is:

- 16-slot or 8-slot card cage
- Modular power supply
- Fan tray (cabinet servers) or fan box (standalone server)
- Clock board
- CPU/memory board
- I/O board
- Peripheral power supply
- AC distribution unit
- SCSI receptacle for removable media, including CD-ROM



Sun Enterprise systems have extensive error detection mechanisms, and an Automatic System Reconfiguration (ASR) feature that enables the system to be rebooted with failed components (such as CPUs, memory, or I/O) disabled. When an error is detected, the system is reconfigured so that the board containing the failed components is placed in low power mode and is no longer accessible.

The hot-plugable feature inserts a new board into a powered up system, despite being “live,” or being supplied with electrical power. Once a working board is added to a powered on system with the hot-plugable feature, the Solaris 2.5.1 or 2.6 software environments will not use the new board until the system is rebooted. The systems also support hot-plugable disk drives and redundant, hot-plugable power and cooling units.

High speed networking is supported by integrated 10 or 100 Mb Ethernet and optional ATM interface.

The systems support remote control administration, which enables remote rebooting and power cycling.

The system monitor for these servers is Solstice™ SyMON™, a system performance tool that you can use to:

- Monitor the performance of a large server with multiple processors, I/O, and disks.
- Optimize the configuration and throughput of the server.
- Identify hardware and software failures quickly. Failures range from major failures (CPU crash), to minor failures (slow cooling fan). Solstice SyMON identifies the component or software and its location.
- Monitor hardware performance to detect incipient hardware failure (soft read errors on a disk).

## Sun Enterprise 3500, 4500, 5500, and 6500 Systems

The 3500-6500 mid range server line uses the 336 MHz UltraSPARC™ processor and the 84MHz to 100 MHz interconnect called the Sun Gigaplane™ system bus. This server family includes hot-pluggable disk drives, processors, power supplies and cooling. Dynamic Reconfiguration and Alternate Pathing software, which lets you add, remove, or replace system resources while maintaining application availability, is a new feature of these servers. The server family also has CPU power control, a new feature.

The Sun™ Enterprise™3500 server, designed to be an entry-level departmental server, is contained in a tower/deskside enclosure. It has five system slots that can be used for either CPU/memory boards or I/O boards and contains up to eight CPUs. It has up to 8 Gbytes of memory, 72.8 GBytes of internal disk storage, and can

provide greater than 2 Terabytes of maximum total disk storage. The system also includes one CD-ROM drive and an optional tape drive. It includes disk bays for eight dual-ported FC-AL disk drives.

The Sun Enterprise 4500 server is housed in a tabletop enclosure and has eight system slots providing capacity for up to 14 CPUs. It is designed to be a high end departmental server and has up to 14 Gbytes of memory. The server provides 33.6 Gbytes of internal storage and can provide up to 4 Terabytes of maximum total disk storage. The server also contains one tape drive.

The Sun Enterprise 5500 server, designed to be an entry-level datacenter server, also has eight system slots providing up to 14 CPUs but the enclosure is a 68-inch cabinet. It contains up to 14 Gbytes of memory. It provides up to 509 Gbytes of internal storage and has the capability to provide greater than 6 Terabytes of maximum total disk storage. The server also contains a tape library.

The Sun Enterprise 6500 server, a high-end datacenter server, also is housed in a 68-inch cabinet. It has 16 system slots and can contain up to 30 CPUs and 30 Gbytes of memory. The server provides 382 Gbytes of internal storage and can provide greater than 10 Terabytes of maximum total disk storage. The server also contains a tape library. The system rack provides support for multiple internal disk subsystems and tape options.

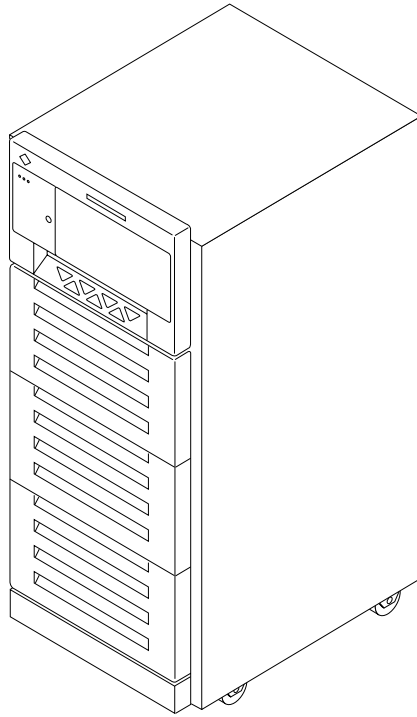

Sun Enterprise 6500/5500

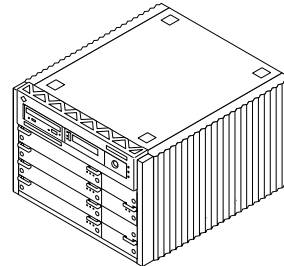

Sun Enterprise 4500

**FIGURE 2-3** Front View of the Sun Enterprise 6500, 5500, and 4500 Servers

## SPARCcenter 2000 and SPARCcenter 2000E Systems

The SPARCcenter 2000 and the SPARCcenter 2000E systems, which were introduced in 1992, provide the computing solution for a company. As such, the SPARCcenter 2000 system and the SPARCcenter 2000E system are multifunctional network NFS file servers. They support less than 500 NFS clients and have the flexibility required for dedicated or multifunctional application environments.

The SPARCcenter 2000 system and the SPARCcenter 2000E system provide scalability and extensive expansion in these areas:

- CPU processor power
- Memory capability
- I/O connectivity

They meet the following requirements:

- High capacity I/O requirements of corporate data centers
- Computationally intensive demands of other organizations

The heart of the SPARCcenter 2000 system or the SPARCcenter 2000E system is a high-speed packet-switched bus complex that provides very high data transfer bandwidth. The backplane supports two distinct XDBuses operating in parallel.

The SPARCcenter 2000 system or the SPARCcenter 2000E system use up to twenty SuperSPARC™ modules in a shared-memory symmetric multiprocessing configuration, meeting most performance needs. You can expand or upgrade the processing capability by adding SuperSPARC modules.

Main memory is configured in multiple logical units that are installed in the bus complex.

The I/O is expandable. For example, you can configure up to 40 SBus slots on 10 independent buses. The large I/O capacity and configurability makes the SPARCcenter 2000 system or the SPARCcenter 2000E system suitable for very large applications.

The system monitor for this server is Solstice SyMON.

### *SPARCserver 1000 and the SPARCserver 1000E System Features*

The SPARCserver 1000 and the SPARCserver 1000E systems have the following features:

- Up to four system boards can be installed
- Up to eight SuperSPARC processors (two per system board) can be installed
- Up to 2 Gbytes of main memory (using 32 Mbyte SIMMs) can be installed
- Up to 16.8 Gbytes of internal storage
- 50 MHz system clock speed in the SPARCserver 1000E system (40 MHz in the SPARCserver 1000 system)
- 25 MHz SBus speed in the SPARCserver 1000E system (20 MHz in the SPARCserver 1000 system)
- When connected to 12 SPARCstorage Array subsystems, the SPARCserver 1000 or 1000E systems provide up to 756 Gbytes of external storage
- Up to 12 SBus slots
- Onboard SCSI-2 port and twisted pair Ethernet on each system board
- Internal 5 Gbyte 4mm tape drive (or 10 Gbyte 8mm tape drive)
- Internal CD-ROM drive
- NVRAM-NVSIMM Prestoserve NFS accelerator (optional)

## Workgroup Servers

This section presents an overview of the following workgroup servers:

- Sun Enterprise 150 server system
- Sun Enterprise 250 serversystem

- Sun Enterprise 450 serversystem
- Sun Enterprise 2 server system
- Sun Enterprise 1 server system
- SPARCserver 20 server system

The highest capacity workgroup servers are presented first.

## Sun Enterprise 150 Server System

The Sun Enterprise 150 server system is a tower workgroup server based on the 167 MHz UltraSPARC™ microprocessor. It has the following features:

- Autosensing 10/100 Mbps Fast Ethernet
- 10 Mbps Ethernet
- 20 Mbyte/second Fast/Wide SCSI-2 peripheral interface
- ECC-protected memory
- Internal disk array with up to twelve hot-plugable disks supporting RAID 0 (disk striping), RAID 1 (disk mirroring), and RAID 5 (hot spares) providing 48 Gbytes of disk capacity (based on 4 Gbyte disk drives)
- 1.44 Mbyte diskette drive
- 644 Mbyte CD-ROM drive

The Sun Enterprise 150 server system is ideal for an NFS server because it is a high-end workgroup server with high I/O performance and fast system throughput.

FIGURE 2-4 shows a front view of the server.

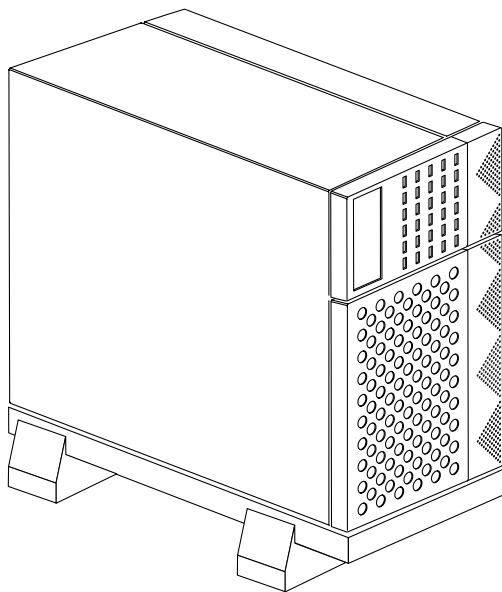

**FIGURE 2-4** Sun Enterprise 150 Front View

For additional disk storage, you can attach either the Sun StorEdge UniPack or the Sun StorEdge MultiPack to the server. If you need greater amounts of disk storage, use the SPARCstorage Array to the server. For a backup device, use the SPARCstorage Library, which holds ten cartridges in a removable magazine for an average total capacity of 140 Mbytes.

## Sun Enterprise 250 System

The Sun Enterprise 250 system server is a mid-range server with up to 54 Gbytes of disk storage, dual CPU processors, and fast PCI I/O channels.

Software features are:

- RAID 0 (disk striping), RAID 1 (disk mirroring), and RAID 5 (hot spares)
- System performance and configuration monitors
- Automated hardware failure notification
- Error and panic logging
- Temperature sensing and fan control
- Backup power supply failure detection
- Hot sparing support
- Automatic fault detection, response, and recovery
- Logging file systems

- Secure remote system monitoring feature for geographically distributed or physically inaccessible systems

Hardware features are:

- Four PCI slots supporting up to four full size PCI cards (three regular PCI slots and one enhanced PCI slot)
- Up to sixteen SIMM slots, which support 16, 32, 64, or 128 Mbyte SIMMs totaling up to 2 Gbytes of memory capacity
- 10/100 Mbit Ethernet
- 20 Mbyte/second Fast Wide SCSI
- Up to two CPU modules (UltraSPARC-II)
- Up to six 1.6-inch high or 1-inch high UltraSCSI disks
- 1.44 Mbyte diskette drive
- 644 Mbyte CD-ROM drive
- Two 5 1/4-inch x 1.6-inch removable media bays
- Two high speed synchronous/asynchronous serial ports
- Up to two redundant hot swappable power supplies
- Module to provide remote system monitoring capability
- Supports rack mounting allowing the system to integrate easily into a computer room environment

FIGURE 2-5 shows a front view of the Sun Enterprise 250 system.

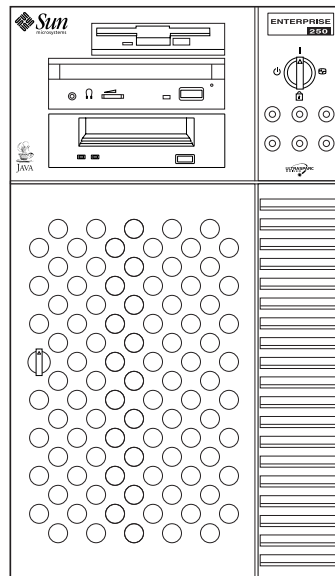

FIGURE 2-5 Sun Enterprise 250 Front View

## Sun Enterprise 450 System

The Sun Enterprise 450 system server, based on the UltraSPARC-II™ processor, is designed for mid-range server markets that require large amounts of local disk storage with fast or multiple I/O channels to clients or to the network.

Software features are:

- Support for RAID 1 (disk mirroring), RAID 3 (striping data and parity across drive groups) and RAID 5 (hot spares for FC-AL disk drives)
- System performance and configuration monitors
- Automated hardware failure notification
- Error and panic logging
- Temperature sensing and fan control
- Backup power supply failure detection
- Hot sparing support
- Automatic fault detection, response, and recovery
- Logging file systems

Hardware features are:

- 10 PCI slots supporting up to 10 full size PCI cards (seven regular PCI slots and three enhanced PCI slots)
- Up to sixteen SIMM slots, which support 32, 64, 128 or 256 Mbyte SIMMs totalling up to 4 Gbytes of memory capacity
- 10/100 Mbit Ethernet
- 20 Mbyte/second Fast Wide SCSI
- Up to four CPU modules (UltraSPARC-II)
- Up to twenty hot swappable FC-AL disks and up to two 1.6-inch high SCSI disks that provide up to 84 Gbytes internal storage
- Up to 6 Terabytes of external disk storage
- 1.44 Mbyte diskette drive
- 644 Mbyte CD-ROM drive
- Two 5 1/4-inch bays for optional tape backup
- Two high speed synchronous/asynchronous serial ports
- Up to three redundant hot swappable power supplies, which can be added one at a time to improve reliability and provide growth as needed
- Supports rack mounting allowing the system to integrate easily into a computer room environment



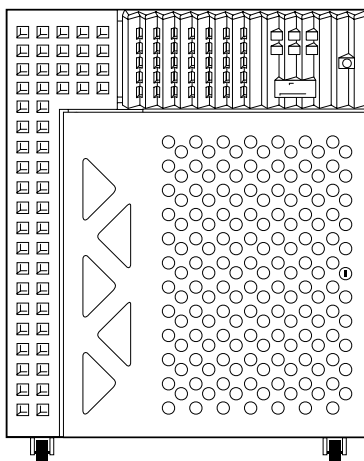

**FIGURE 2-6** Front View of the Sun Enterprise 450 Server

You can attach up to two external tape devices or a single size or twelve drive Sun StorEdge MultiPack to the SCSI port. You can attach additional tape or disk devices by installing PCI host adapter cards. If you require large amounts of disk storage, you can also attach the Sun StorEdge A3000 subsystem to the system that provides a redundant array of inexpensive disks (RAID).

## Sun Enterprise 1 and 2 Systems

The Sun Enterprise 1 system is the first member of a new class of workstations based on the UltraSPARC-I processor and is designed to deliver balanced system performance.

The Sun Enterprise 1 system can be used as a high capacity NFS server for medium to large workgroups (50 to 100 users). It is designed for reliability, availability, and serviceability. It enables easy access to replace disk drives, SIMMs, and graphics cards.

The Sun Enterprise 2 system is a multiprocessor system based on the UltraSPARC-I processor. It is standard with Fast/Wide SCSI and Fast Ethernet, which enables the data throughput capability of this system to include the disk I/O and the network traffic. The system also has a 64-bit SBus running at 25 MHz giving maximum SBus throughput.

The Sun Enterprise 2 system can be used as an NFS server for mid- to large-sized workgroups.

The Ultra SPARC CPU is matched by a very high performance crossbar-switched interconnect that can move data at peak rates of 1.3 Gbytes/second. This interconnect, the Ultra Port Architecture (UPA), is the key to providing the greatly enhanced memory bandwidth. Both the Sun Enterprise 1 and 2 systems have a 64-bit SBus running at 25 MHz giving maximum SBus throughput.

The architecture was designed to be fully compatible with previous generations of workstations so that all Solaris operating environment applications can run unchanged.

FIGURE 2-7 shows a front view of the Sun Enterprise 1 system.

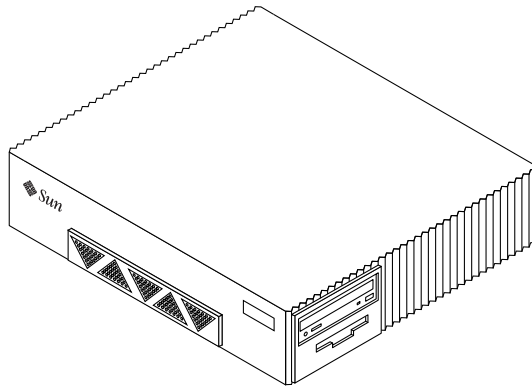

FIGURE 2-7 Sun Enterprise 1 Front View

## SPARCserver 20 System

The SPARCserver 20 system, introduced in 1994, is designed to be a workgroup NFS file server or a database server in an office environment. It is based on the same MBus and SBus technologies as the SPARCserver 10 system. Performance is increased over the SPARCserver 10 by using faster MBus and SBus technology, and faster SPARC modules. The SPARCserver 20 system has increased computing and network performance.

The SPARCserver 20 system is available in three uniprocessor configurations and three multiprocessor configurations.

The uniprocessor configurations are:

- Model 50—50 MHz SuperSPARC processor
- Model 51—50 MHz SuperSPARC processor and 1 Mbyte SuperCache
- Model 61—60 MHz SuperSPARC processor and 1 Mbyte SuperCache
- Model 71—75 MHz SuperSPARC processor and 1 Mbyte SuperCache
- Model 151—one 150 MHz HyperSPARC processor and 0.5 Mbyte external cache

The multiprocessor configurations are:

- Model 502MP—two 50 MHz SuperSPARC processors
- Model 514MP—four 50 MHz SuperSPARC processors and 1 Mbyte SuperCache
- Model 612MP—two 60 MHz SuperSPARC processors and 1 Mbyte SuperCache
- Model 712—two 75 MHz SuperSPARC processors and 1 Mbyte SuperCache
- Model 152MP—two 150 MHz HyperSPARC processors and 0.5 Mbyte of external cache

FIGURE 2-8 shows the front view of the SPARCserver 20 system.

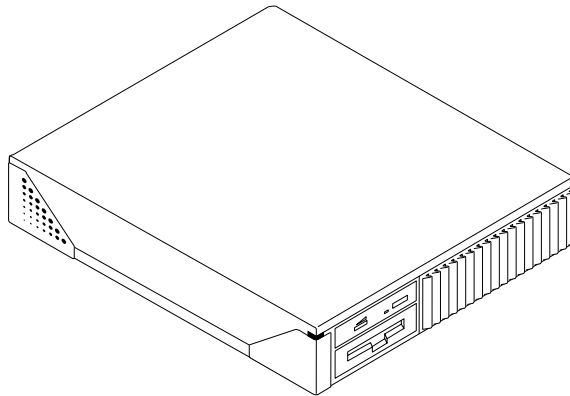

FIGURE 2-8 SPARCserver 20 System Front View

## SPARCserver 20 System Features

The SPARCserver 20 system features include:

- More than 2 Gbytes of internal hard disk storage (two 1.05 Gbyte disk drives)
- Up to 126 Gbytes of disk storage in the SPARCstorage Array (Model 101) subsystems when directly connected to four SPARCstorage Array subsystems
- 1.44 Mbyte diskette drive (optional)
- 644 Mbyte CD-ROM drive (optional)
- Two serial ports, one parallel port
- Twisted-pair Ethernet
- Up to 512 Mbytes of memory (60 ns SIMMs)
- AUI Ethernet (optional) (can have up to 9 Ethernet networks)
- SBus or NVRAM-NVSIMM Prestoserve NFS accelerator (optional)

---

# Disk Expansion Units

This section describes an overview of the following disk expansion units:

- SPARCstorage Array™ subsystem
- Sun StorEdge A1000 RAID system
- Sun StorEdge A3000 subsystem
- Sun StorEdge A5000 subsystem
- Sun StorEdge A7000 Intelligent Storage Server
- Sun StorEdge MultiPack™
- Sun StorEdge UniPack™

## SPARCstorage Array Subsystem

To expand your disk storage, consider the SPARCstorage Array subsystem. This disk array is a high-performance and high-capacity companion unit for the Sun Enterprise 4000, 5000, or 6000 systems, SPARCcenter 2000 or 2000E, SPARCserver 1000 or 1000E, Sun Enterprise 150 system, Sun Enterprise 2 system, and the SPARCserver 20 system.

The Model 101 uses 1.05 Gbyte single connector 3.5-inch disk drives. Each disk array contains three drive trays. Each drive tray supports up to ten 3.5-inch single-connector SCSI disk drives. All disk drive SCSI addresses are hardwired. The position of the disk drive in the drive tray automatically sets the SCSI addresses. Each disk array uses six internal fast, wide SCSI buses. Each drive tray contains two SCSI buses that support five disk drives for each SCSI bus.

FIGURE 2-9 shows a front view of the SPARCstorage Array subsystem.

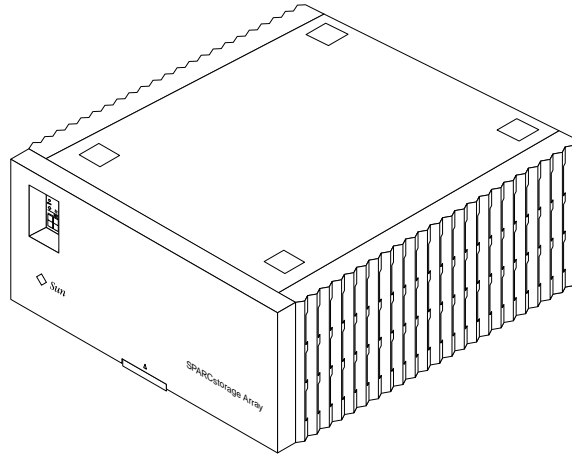

**FIGURE 2-9** Front View of the SPARCstorage Array Subsystem

FIGURE 2-10 shows how you can connect the SPARCstorage Array subsystem to your NFS server.

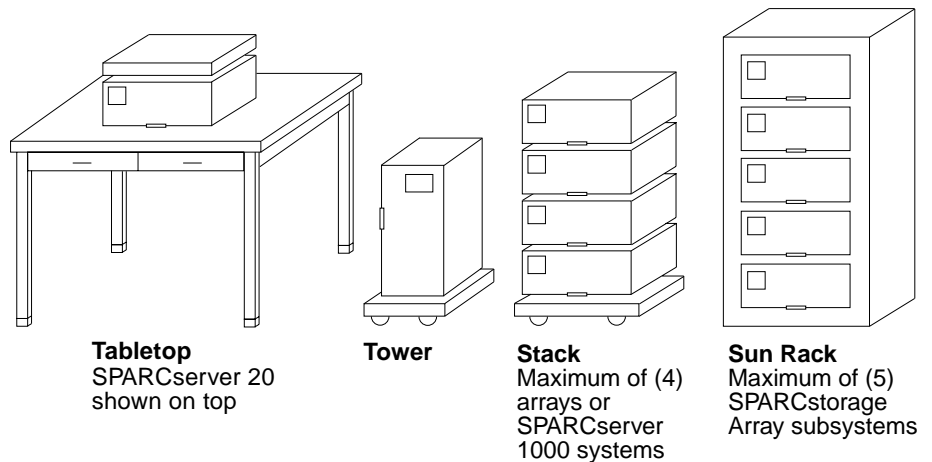

**FIGURE 2-10** SPARCstorage Array Subsystem Installation Options

The SPARCstorage Array subsystem uses RAID (Redundant Array of Inexpensive Disks) technology. RAID 0 stripes data without parity, RAID 1 does disk mirroring, RAID 0+1 does mirroring optimized stripes, and RAID 5 does striping data with parity.

Within the disk array, independent disks plus RAID levels 5, 1, 0, 0+1 are available at the same time so you can easily match data layouts to meet the specific requirements for capacity, performance, high availability, and cost.

If any disk in a RAID-5, 1, or 0+1 group fails, an optional hot spare (if configured) is automatically swapped to replace the failed disk. Continuous, redundant data protection is provided, even if a disk fails.

Warm plug service lets you replace one or more disks without powering down the system and the disk array, or rebooting the system. You can obtain warm plug service if multiple disk arrays are configured.

Using the SPARCstorage Array subsystem can improve NFS performance because its processor manages and schedules disk I/O.

The SPARCstorage Manager software is provided with the disk array and provides similar functionality to Online: Disk Suite software. Since there are often many more disks to manage in the SPARCstorage Array subsystem, the SPARCstorage Manager software has an intuitive GUI interface.

## Sun StorEdge A1000 RAID Disk Array

The Sun StorEdge A1000 unit is a RAID controller-based configuration. It is designed as a RAID solution for workgroup servers and contains the following:

- RAID controller module
- Two power supplies(hot swappable)
- Battery
- Dual cooling fans (hot swappable)
- Up to twelve disk drives (hot swappable)

The RAID Manager controller module provides disk array management services. It supports dual SCSI hosts on a 16-bit SCSI-2 bus. The two SCSI controllers inside the controller module manage data distribution and storage for up to twelve disk drives. The controllers also perform system status and fault detection functions.

The RAID Manager software allows you to reset the disk array in different RAID configurations

FIGURE 2-11 shows a front view of a twelve drive system.

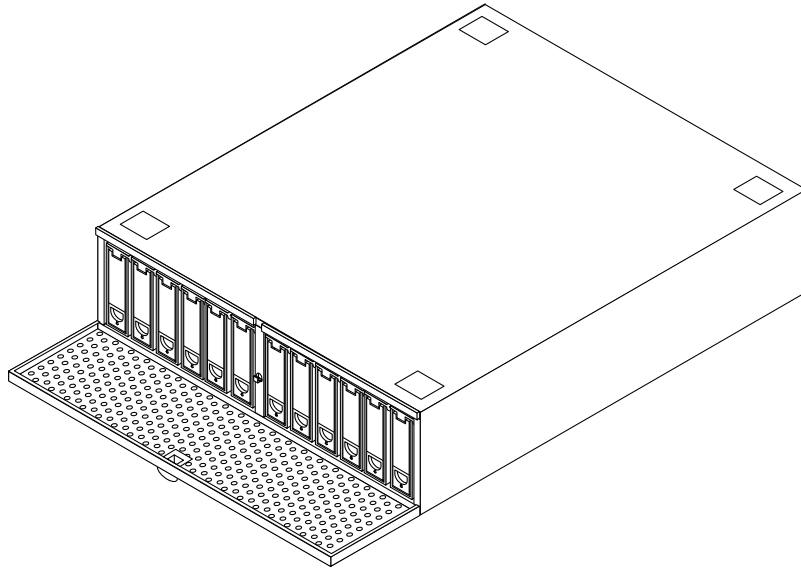

FIGURE 2-11 Sun StorEdge A1000 Front View of a Twelve Drive System

## Sun StorEdge A3000 Subsystem

The Sun StorEdge A3000 subsystem is a redundant array of inexpensive disks (RAID) product. It is offered as a companion unit for the following systems:

- SPARCserver 1000
- SPARCcenter 2000
- Sun Enterprise 3x00, 4x00, 5x00, and 6x00
- Sun Enterprise 450 and 250

It is a high performance rack-mounted disk array controller that features redundant power and cooling by incorporating hot-plug technology to support the unexpected loss of one controller, one fan, or one power supply. Failed disk driver can be hot-plugged without stopping I/O activity to the subsystem.

The controller module, which is installed in the subsystem, supports dual SCSI hosts on a 16-bit SCSI-2 bus. In addition, the unit provides the same SCSI-2 bus interface for up to five differential drive trays in the expansion cabinet.

There are two SCSI controllers inside the controller module that use five independent drive channels to manage data distribution and storage for up to thirty-five disk drives. The controllers perform system status and fault detection functions as well.

The controller module combines disk array technology with redundant modular components to provide fast data transfer rates, plus reliable, high-volume data retrieval and storage functions across multiple drives. It works with the RAID Manager software, a disk array management program for configuring, monitoring, and troubleshooting the disk array and provides high-performance disk array management services.

As part of this overall disk management system, the controller module supports the following disk array elements and configurations:

- RAID levels 0 (disk striping), 1 (disk mirroring), 0+1 (disk striping plus disk mirroring), 3 (data and parity are striped across a drive group), and 5 (hot spares)
- Redundant, dual-active controller configurations
- Hot swapable components (controllers, fans, and so on)
- Fast write cache

With RAID 3, data and parity are striped across a drive group. One drive is used for redundancy. All other drives are available for storing user data. FIGURE 2-12 shows a front view of the Sun StorEdge A3000 subsystem.

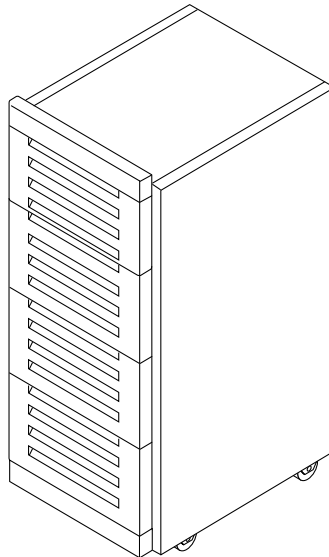

**FIGURE 2-12** Front View of the Sun StorEdge A3000 Subsystem



# Sun StorEdge A5000 Subsystem

This high-performance and high-availability storage subsystem is designed for the Sun Enterprise 3x00, 4x00, 5x00, and 6x00 family of servers. It replaces the SPARCstorage Array. This subsystem uses 100 Mbit/second Fibre Channel Arbitrated Loop (FC-AL) to create disk arrays that offer two to four times the performance of SCSI-based disk arrays.

The hardware features of this product are:

- 100 Mbit/second PCI and FC-AL host adapters
- Fully redundant hardware drive chassis for rack and tabletop configurations supporting 1.6-inch and 1-inch disk drives
- Optional FC-AL hub

The software features of this product are:

- Volume manager with RAID support
- I/O driver for the FC-AL host adapter
- Solstice SyMON and SNMP support
- Management GUI

This subsystem can store up to 112 Gbytes of information (using 1.6-inch disk drives) or 88 Gbytes of information (using 1-inch disk drives). You can attach up to four disk enclosures using one host adapter. The components in the enclosure are redundant and can be replaced while the subsystem is operating.

FIGURE 2-13 shows a front view of the array.

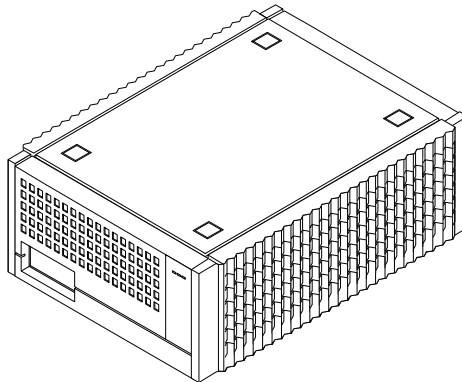

**FIGURE 2-13** Front View of the Sun StorEdge A5000 Subsystem

# Sun StorEdge A7000 Intelligent Storage Server

The Sun StorEdge A7000 Intelligent Storage Server is a mainframe-class disk array system containing nearly 3 Terrabytes of disk storage. It is designed for the Sun Enterprise 6000 or 6500 data center system. The system contains Symmetric Multiprocessor (SMP) nodes as storage processors. The DataShare software, which runs on this disk array, permits both mainframe and open systems' hosts to directly share the data on the same data volume.

Hardware features of this disk array include fully redundant hardware controllers, cache, hot-pluggable disks, fans, power, and power cords.

Software features include configurable RAID levels, self-diagnostics, health-monitoring, environmental-monitoring, and performance-monitoring.

Serviceability features include automatic "phone home" and problem reporting supports by on-line diagnostics and repair capability.

## Sun StorEdge MultiPack

The Sun StorEdge MultiPack™ enclosure, which is Fast Wide SCSI, can adapt to 50-pin or narrow hosts. It is self-terminating but it can be chained with units that require external termination.

The Sun StorEdge MultiPack uses single connector disks and it is hot pluggable. The enclosure can either contain from two to six 1.5-inch disk drives or from two to twelve 1-inch disk drives. To accommodate from two to twelve 1-inch disk drives you must use an SBus SCSI host adapter.

This unit is an excellent RAID solution for desktop servers when you use the unit with Sun StorEdge Volume Manager™ or Solstice™ DiskSuite™. You can also use the Sun StorEdge MultiPack with the Netra NFS server for fast and reliable network attached storage.

FIGURE 2-14 shows a front view of the Sun StorEdge MultiPack

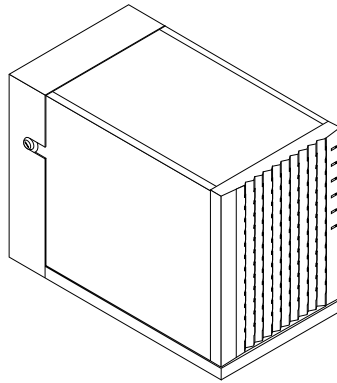

**FIGURE 2-14** Front View of the Sun StorEdge MultiPack

## Sun StorEdge UniPack

The disk model of the Sun StorEdge UniPack™ enclosure (FIGURE 2-15) contains a self terminating hard disk drive. Models containing a tape drive or a CD-ROM drive are also available. The unit is Fast Wide SCSI.

This expansion unit can be used with the following desktop server systems: SPARCstation 5 system, SPARCstation 10 system, SPARCstation 20 system, Sun Enterprise 1 system, Sun Enterprise 2 system.

This unit can be a very good RAID solution for desktop servers when used with Sun StorEdge Volume Manager™ or Solstice™ DiskSuite™. You can also use this unit with the Netra NFS server for fast and reliable network attached storage.

FIGURE 2-15 shows a front view of the unit.

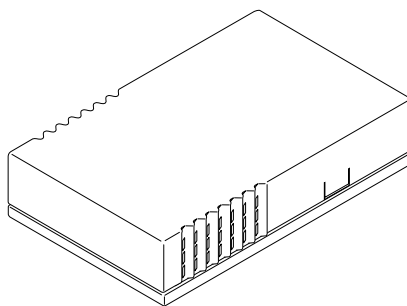

**FIGURE 2-15** Sun StorEdge UniPack



# Analyzing NFS Performance

---

This chapter explains how to analyze NFS performance and describes the general steps for tuning your system. This chapter also describes how to verify the performance of the network, server, and each client.

---

## Tuning the NFS Server

When you first set up the NFS server, you need to tune it for optimal performance. Later, in response to a particular problem, you need to tune the server again to optimize performance.

## Optimizing Performance

Follow these steps in sequence to improve the performance of your NFS server.

1. Measure the current level of performance for the network, server, and each client. See “Checking Network, Server, and Client Performance” later in this chapter.
2. Analyze the gathered data by graphing it. Look for exceptions, high disk and CPU utilization, and high disk service times. Apply thresholds or performance rules to the data.
3. Tune the server. See Chapter 4.
4. Repeat Steps 1 through 3 until you achieve the desired performance.

# Resolving Performance Problems

Follow these steps in sequence to resolve performance problems with your NFS server.

1. Use tools then observe the symptoms to pinpoint the source of the problem.
2. Measure the current level of performance for the network, server, and each client. See “Checking Network, Server, and Client Performance.”
3. Analyze the data gathered by graphing the data. Look for exceptions, high disk and CPU utilization, and high disk service times. Apply thresholds or performance rules to the data.
4. Tune the server. See Chapter 4.
5. Repeat Steps 1 through 4 until you achieve the desired performance.

---

## Checking Network, Server, and Client Performance

Before you can tune the NFS server, you must check the performance of the network, the NFS server, and each client. The first step is to check the performance of the network. If disks are operating normally, check network usage because a slow server and a slow network look the same to an NFS client.

FIGURE 3-1 illustrates the steps you must follow in sequence to check the network.

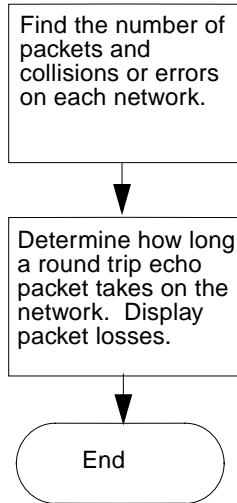

FIGURE 3-1 Flow Diagram for Checking the Network Performance

## ▼ To Check the Network

### 1. Find the number of packets, collisions, or errors on each network by typing

`netstat -i 15`.

To look at other interfaces use `-I`.

```

server% netstat -i 15
      input  le0      output  input      (Total)  output
packets errs  packets errs  colls  packets errs  packets errs  colls
10798731 533   4868520 0      1078   24818184 555   14049209 157   894937
51      0     43      0     0      238      0     139      0     0
85      0     69      0     0      218      0     131      0     2
44      0     29      0     0      168      0     94       0     0
  
```

A description of the arguments to the `netstat` command follows:

TABLE 3-1 `netstat -i 15` Command Arguments

<code>-i</code>	Shows the state of the interfaces that are used for TCP/IP traffic
<code>15</code>	Collects information every 15 seconds

In the `netstat -i` display, a machine with active network traffic should show both input packets and output packets continually increasing.

**2. Calculate the network collision rate by dividing the number of output collision counts (Output Colls - le) by the number of output packets (le).**

A network-wide collision rate greater than 10 percent can indicate an overloaded network, a poorly configured network, or hardware problems.

**3. Calculate the input packet error rate by dividing the number of input errors (le) by the total number of input packets (le).**

If the input error rate is high (over 25 percent), the host may be dropping packets.

Transmission problems can be caused by other hardware on the network, as well as heavy traffic and low-level hardware problems. Bridges and routers can drop packets, forcing retransmissions and causing degraded performance.

Bridges also cause delays when they examine packet headers for Ethernet addresses. During these examinations, bridge network interfaces may drop packet fragments.

To compensate for bandwidth-limited network hardware:

- Reduce the packet size specifications.
- Set the read buffer size, `rsize`, and the write buffer size, `wsize`, when using `mount` or in the `/etc/vfstab` file. Reduce the appropriate variable(s) (depending on the direction of data passing through the bridge) to 2048. If data passes in both directions through the bridge or other device, reduce both variables:

```
server:/home /home/server nfs rw,rsize=2048,wsize=2048 0 0
```

If a lot of read and write requests are dropped and the client is communicating with the server using the User Datagram Protocol (UDP), then the entire packet will be retransmitted, instead of the dropped packets.

**4. Determine how long a round trip echo packet takes on the network by typing `ping -sRv servername` from the client to show the route taken by the packets.**

If the round trip takes more than a few milliseconds, there are slow routers on the network, or the network is very busy. Ignore the results from the first `ping` command. The `ping -sRv` command also displays packet losses.



The following screen shows the output of the `ping -sRv` command.

```
client% ping -sRv servername
PING server: 56 data bytes
64 bytes from server (129.145.72.15): icmp_seq=0. time=5. ms
  IP options: <record route> router (129.145.72.1), server
(129.145.72.15), client (129.145.70.114), (End of record)
64 bytes from server (129.145.72.15): icmp_seq=1. time=2. ms
  IP options: <record route> router (129.145.72.1), server
(129.145.72.15), client (129.145.70.114), (End of record)
```

A description of the arguments to the `ping` command follows:

**TABLE 3-2** Arguments to the `ping -sRv` Command

s	Send option. One datagram is sent per second and one line of output is printed for every echo response it receives. If there is no response, no output is produced.
R	Record route option. The Internet Protocol (IP) record option is set so that it stores the route of the packet inside the IP header.
v	Verbose option. ICMP packets other than echo response that are received are listed.

If you suspect a physical problem, use `ping -sRv` to find the response time of several hosts on the network. If the response time (ms) from one host is not what you expect, investigate that host.

The `ping` command uses the ICMP protocol's echo request datagram to elicit an ICMP echo response from the specified host or network gateway. It can take a long time on a time-shared NFS server to obtain the ICMP echo. The distance from the client to the NFS server is a factor for how long it takes to obtain the ICMP echo from the server.

FIGURE 3-2 shows the possible responses or the lack of response to the `ping -sRv` command.

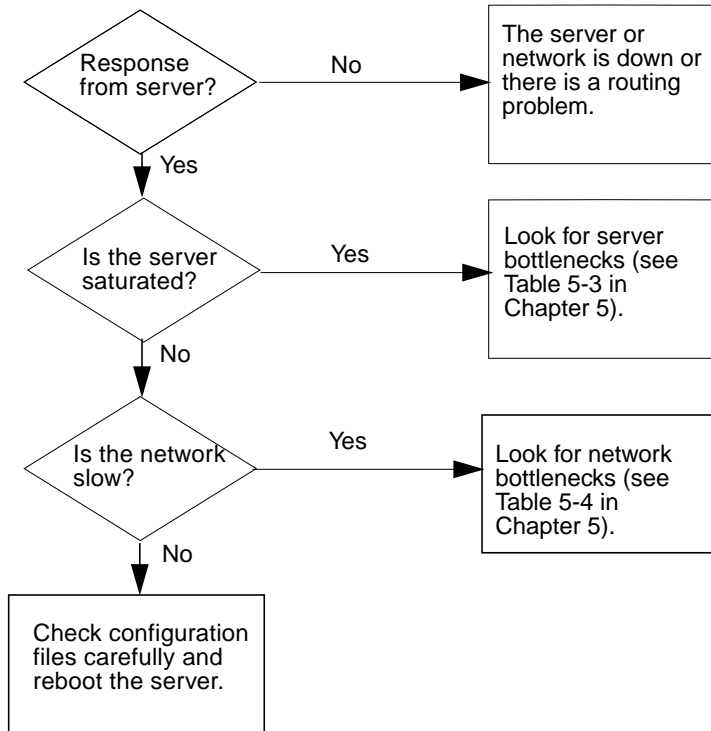

FIGURE 3-2 Flow Diagram of Possible Responses to the `ping -sRv` Command

## Checking the NFS Server

---

**Note** – The server used in the following examples is a large SPARCserver 690 configuration.

---

### ▼ To Check the NFS Server

1. Determine what is being exported by typing `share`.

```

server% share
-          /export/home  rw=netgroup  ""
-          /var/mail     rw=netgroup  ""
-          /cdrom/solaris_2_3_ab  ro   ""
  
```

**2. Display the file systems mounted and the disk drive on which the file system is mounted by typing `df -k`.**

If a file system is over 100 percent full, it may cause NFS write errors on the clients.

```
server% df -k
Filesystem            kbytes    used  avail capacity  Mounted on
/dev/dsk/c1t0d0s0     73097     36739  29058     56%    /
/dev/dsk/c1t0d0s3    214638    159948  33230     83%    /usr
/proc                 0          0       0         0%    /proc
fd                   0          0       0         0%    /dev/fd
swap                 501684     32     501652     0%    /tmp
/dev/dsk/c1t0d0s4    582128    302556  267930     53%    /var/mail
/dev/md/dsk/d100     7299223   687386  279377     96%    /export/home
/vol/dev/dsk/c0t6/solaris_2_3_ab
113512             113514    0         100%    /cdrom/solaris_2_3_ab
```

---

**Note** – For this example, the `/var/mail` and `/export/home` file systems are used.

---

Determine on which disk the file systems returned by the `df -k` command are stored.

In the previous example, note that `/var/mail` is stored on `/dev/dsk/c1t0d0s4` and `/export/home` is stored on `/dev/md/dsk/d100`, an Online: DiskSuite™ metadisk.

**3. Determine the disk number if an Online: DiskSuite metadisk is returned by the `df -k` command by typing `/usr/opt/SUNWmd/sbin/metastat disknumber`.**

In the previous example, `/usr/opt/SUNWmd/sbin/metastat d100` determines what physical disk `/dev/md/dsk/d100` uses.

The d100 disk is a mirrored disk. Each mirror is made up of three striped disks of one size concatenated with four striped disks of another size. There is also a hot spare disk. This system uses IPI disks (*idX*). SCSI disks (*sdX*) are treated identically.

```

server% /usr/opt/SUNWmd/sbin/metastat d100
d100: metamirror
  Submirror 0: d10
    State: Okay
  Submirror 1: d20
    State: Okay
  Regions which are dirty: 0%
d10: Submirror of d100
  State: Okay
  Hot spare pool: hsp001
  Size: 15536742 blocks
  Stripe 0: (interlace : 96 blocks)
  Device          Start Block  Dbase State      Hot Spare
  /dev/dsk/clt1d0s7      0      No   Okay
  /dev/dsk/c2t2d0s7      0      No   Okay
  /dev/dsk/clt3d0s7      0      No   Okay
  Stripe 1: (interlace : 64 blocks)
  Device          Start Block  Dbase State      Hot Spare
  /dev/dsk/c3t1d0s7      0      No   Okay
  /dev/dsk/c4t2d0s7      0      No   Okay
  /dev/dsk/c3t3d0s7      0      No   Okay
  /dev/dsk/c4t4d0s7      0      No   Okay
d20: Submirror of d100
  State: Okay
  Hot spare pool: hsp001
  Size: 15536742 blocks
  Stripe 0: (interlace : 96 blocks)
  Device          Start Block  Dbase State      Hot Spare
  /dev/dsk/c2t1d0s7      0      No   Okay
  /dev/dsk/clt2d0s7      0      No   Okay
  /dev/dsk/c2t3d0s7      0      No   Okay
  Stripe 1: (interlace : 64 blocks)
  Device          Start Block  Dbase State      Hot Spare
  /dev/dsk/c4t1d0s7      0      No   Okay
  /dev/dsk/c3t2d0s7      0      No   Okay
  /dev/dsk/c4t3d0s7      0      No   Okay
  /dev/dsk/c3t4d0s7      0      No   Okay    /dev/dsk/c2t4d0s7

```

4. Determine the `/dev/dsk` entries for each exported file system. Use either the `whatdev` script to find the instance or nickname for the drive or type `ls -lL /dev/dsk/c1t0d0s4` and more `/etc/path_to_inst` to find the `/dev/dsk` entries. An explanation of these steps follows.

5. If you will determine the `/dev/dsk` entries for exported file systems with the `whatdev` script, follow these steps:

a. Type the following `whatdev` script using a text editor.

```
#!/bin/csh
# print out the drive name - st0 or sd0 - given the /dev entry
# first get something like "/iommu/.../.../sd@0,0"
set dev = `/bin/ls -l $1 | nawk '{ n = split($11, a, "/"); split(a[n],b,":");
for(i = 4; i < n; i++) printf("/%s",a[i]); printf("/%s\n", b[1]) }`
if ( $dev == "" ) exit
# then get the instance number and concatenate with the "sd"
nawk -v dev=$dev '$1 ~ dev { n = split(dev, a, "/"); split(a[n], \
b, "@"); printf("%s%s\n", b[1], $2) }' /etc/path_to_inst
```

b. Determine the `/dev/dsk` entry for the file system by typing `df /filesystemname`.

In this example you would type `df /var/mail`.

```
furious% df /var/mail
Filesystem          kbytes    used    avail capacity  Mounted on
/dev/dsk/c1t0d0s4   582128   302556  267930    53%    /var/mail
```

c. Determine the disk number by typing `whatdev diskname` (the disk name returned by the `df /filesystemname` command).

In this example you would type `whatdev /dev/dsk/c1t0d0s4`. Disk number `id8` is returned, which is IPI disk 8.

```
server% whatdev /dev/dsk/c1t0d0s4
id8
```

d. Repeat steps b and c for each file system not stored on a metadisk (`dev/md/dsk`).

e. If the file system is stored on a meta disk, (`dev/md/dsk`), look at the `metastat` output and run the `whatdev` script on *all* drives included in the metadisk.

In this example type `whatdev /dev/dsk/c2t1d0s7`.

There are 14 disks in the /export/home file system. Running the `whatdev` script on the `/dev/dsk/c2t1d0s7` disk, one of the 14 disks comprising the /export/home file system, returns the following display.

```
server% whatdev /dev/dsk/c2t1d0s7
id17
```

Note that `/dev/dsk/c2t1d0s7` is disk `id17`; this is IPI disk 17.

**f. Go to Step 7.**

**6. If you didn't determine the /dev/dsk entries for exported file systems with the `whatdev` script, you need to identify the /dev/dsk entries for exported file systems with `ls -lL`. Follow these steps:**

**a. List the drive and its major and minor device numbers by typing**

```
ls -lL disknumber.
```

For example, for the `/var/mail` file system, type:

```
ls -lL /dev/dsk/c1t0d0s4.
```

```
ls -lL /dev/dsk/c1t0d0s4
brw-r----- 1 root      66,  68 Dec 22 21:51 /dev/dsk/c1t0d0s4
```

**b. Locate the minor device number in the `ls -lL` output.**

In the previous screen example, the first number following the file ownership (`root`), `66`, is the major number. The second number, `68`, is the minor device number.

**c. Determine the disk number.**

- Divide the minor device number, `68` in the previous example, by `8` ( $68/8 = 8.5$ ).
- Truncate the fraction. The number `8` is the disk number.

**d. Determine the slice (partition) number.**

Look at the number following the `s` (for slice) in the disk number. For example, in `/dev/dsk/c1t0d0s4`, the `4` following the `s` refers to slice `4`.

Now you know that the disk number is `8` and the slice number is `4`. This disk is either `sd8` (SCSI) or `ip8` (IPI).

7. View the disk statistics for each disk by typing `iostat -x 15`. The `-x` option supplies extended disk statistics. The 15 means disk statistics are gathered every 15 seconds.

```
server% iostat -x 15
extended disk statistics
disk      r/s    w/s    Kr/s    Kw/s  wait  actv  svc_t   %w   %b
id10     0.1   0.2    0.4    1.0   0.0   0.0   24.1   0    1
id11     0.1   0.2    0.4    0.9   0.0   0.0   24.5   0    1
id17     0.1   0.2    0.4    1.0   0.0   0.0   31.1   0    1
id18     0.1   0.2    0.4    1.0   0.0   0.0   24.6   0    1
id19     0.1   0.2    0.4    0.9   0.0   0.0   24.8   0    1
id20     0.0   0.0    0.1    0.3   0.0   0.0   25.4   0    0
id25     0.0   0.0    0.1    0.2   0.0   0.0   31.0   0    0
id26     0.0   0.0    0.1    0.2   0.0   0.0   30.9   0    0
id27     0.0   0.0    0.1    0.3   0.0   0.0   31.6   0    0
id28     0.0   0.0    0.0    0.0   0.0   0.0    5.1   0    0
id33     0.0   0.0    0.1    0.2   0.0   0.0   36.1   0    0
id34     0.0   0.2    0.1    0.3   0.0   0.0   25.3   0    1
id35     0.0   0.2    0.1    0.4   0.0   0.0   26.5   0    1
id36     0.0   0.0    0.1    0.3   0.0   0.0   35.6   0    0
id8      0.0   0.1    0.2    0.7   0.0   0.0   47.8   0    0
id9      0.1   0.2    0.4    1.0   0.0   0.0   24.8   0    1
sd15     0.1   0.1    0.3    0.5   0.0   0.0   84.4   0    0
sd16     0.1   0.1    0.3    0.5   0.0   0.0   93.0   0    0
sd17     0.1   0.1    0.3    0.5   0.0   0.0   79.7   0    0
sd18     0.1   0.1    0.3    0.5   0.0   0.0   95.3   0    0
sd6      0.0   0.0    0.0    0.0   0.0   0.0  109.1   0    0
```

Use the `iostat -x 15` command to see the disk number for the extended disk statistics. In the next procedure you will use a `sed` script to translate the disk names into disk numbers.

The output for the extended disk statistics is:

**TABLE 3-3** Ouput of the `iostat -x 15` Command (Extended Disk Statistics)

<code>r/s</code>	Reads per second
<code>w/s</code>	Writes per second
<code>Kr/s</code>	Kbytes read per second
<code>Kw/s</code>	Kbytes written per second
<code>wait</code>	Average number of transactions waiting for service (queue length)
<code>actv</code>	Average number of transactions actively being serviced

**TABLE 3-3** Ouput of the `iostat -x 15` Command (Extended Disk Statistics)

---

<code>svc_t</code>	Average service time, (milliseconds)
<code>%w</code>	Percentage of time the queue is not empty
<code>%b</code>	Percentage of time the disk is busy

---

## 8. Translate disk names into disk numbers

Use `iostat` and `sar`. One quick way to do this is to use a `sed` script.

- a. Type a `sed` script using a text editor similar to the following `d2fs.server` `sed` script.**

Your `sed` script should substitute the file system name for the disk number.

In this example, disk `id8` is substituted for `/var/mail` and disks `id9`, `id10`, `id11`, `id17`, `id18`, `id19`, `id25`, `id26`, `id27`, `id28`, `id33`, `id34`, `id35`, and `id36` are substituted for `/export/home`.

```
sed `s/id8 /var/mail/
    s/id9 /export/home/
    s/id10 /export/home/
    s/id11 /export/home/
    s/id17 /export/home/
    s/id18 /export/home/
    s/id25 /export/home/
    s/id26 /export/home/
    s/id27 /export/home/
    s/id28 /export/home/
    s/id33 /export/home/
    s/id34 /export/home/
    s/id35 /export/home/
    s/id36 /export/home/`
```

- b. Run the `iostat -xc 15` command through the `sed` script by typing**

```
iostat -xc 15 | d2fs.server.
```

The options to the previous `iostat -xc 15 | d2fs.server` command are explained below.

**TABLE 3-4** Options to the `iostat -xc 15 | d2fs.server` Command

---

<code>-x</code>	Supplies extended disk statistics
<code>-c</code>	Reports the percentage of time the system was in user mode ( <code>us</code> ), system mode ( <code>sy</code> ), waiting for I/O ( <code>wt</code> ), and idling ( <code>id</code> )
<code>15</code>	Means disk statistics are gathered every 15 seconds

---



The following explains the output and headings of the `iostat -xc 15 | d2fs.server` command.

```
% iostat -xc 15 | d2fs.server
extended disk statistics          cpu
disk                             r/s  w/s  Kr/s  Kw/s  wait  actv  svc_t  %w  %b  us  sy  wt  id
export/home                       0.1  0.2   0.4   1.0  0.0  0.0   24.1  0  1   0 11  2 86
export/home                       0.1  0.2   0.4   0.9  0.0  0.0   24.5  0  1
export/home                       0.1  0.2   0.4   1.0  0.0  0.0   31.1  0  1
export/home                       0.1  0.2   0.4   1.0  0.0  0.0   24.6  0  1
export/home                       0.1  0.2   0.4   0.9  0.0  0.0   24.8  0  1
id20                              0.0  0.0   0.1   0.3  0.0  0.0   25.4  0  0
export/home                       0.0  0.0   0.1   0.2  0.0  0.0   31.0  0  0
export/home                       0.0  0.0   0.1   0.2  0.0  0.0   30.9  0  0
export/home                       0.0  0.0   0.1   0.3  0.0  0.0   31.6  0  0
export/home                       0.0  0.0   0.0   0.0  0.0  0.0    5.1  0  0
export/home                       0.0  0.0   0.1   0.2  0.0  0.0   36.1  0  0
export/home                       0.0  0.2   0.1   0.3  0.0  0.0   25.3  0  1
export/home                       0.0  0.2   0.1   0.4  0.0  0.0   26.5  0  1
export/home                       0.0  0.0   0.1   0.3  0.0  0.0   35.6  0  0
var/mail                          0.0  0.1   0.2   0.7  0.0  0.0   47.8  0  0
id9                               0.1  0.2   0.4   1.0  0.0  0.0   24.8  0  1
sd15                              0.1  0.1   0.3   0.5  0.0  0.0   84.4  0  0
sd16                              0.1  0.1   0.3   0.5  0.0  0.0   93.0  0  0
sd17                              0.1  0.1   0.3   0.5  0.0  0.0   79.7  0  0
sd18                              0.1  0.1   0.3   0.5  0.0  0.0   95.3  0  0
sd6                               0.0  0.0   0.0   0.0  0.0  0.0  109.1  0  0
```

The following is a description of the output for the `iostat -xc 15 | d2fs.server` command.

**TABLE 3-5** Output for the `iostat -xc 15` Command

<code>disk</code>	Name of disk device
<code>r/s</code>	Average read operations per second
<code>w/s</code>	Average write operations per second
<code>Kr/s</code>	Average Kbytes read per second
<code>Kw/s</code>	Average Kbytes written per second
<code>wait</code>	Number of requests outstanding in the device driver queue
<code>actv</code>	Number of requests active in the disk hardware queue
<code>%w</code>	Occupancy of the wait queue
<code>%b</code>	Occupancy of the active queue—device busy

**TABLE 3-5** Output for the `iostat -xc 15` Command (Continued)

---

<code>svc_t</code>	Average service time in milliseconds for a complete disk request; includes wait time, active queue time, seek rotation, and transfer latency
<code>us</code>	CPU time
<code>sy</code>	System time
<code>wt</code>	Wait for I/O time
<code>id</code>	Idle time

---

**c. Run the `sar -d 15 1000` command through the `sed` script by typing**

```
sar -d 15 1000 | d2fs.server.
```

```
server% sar -d 15 1000 | d2fs.server
```

12:44:17	device	%busy	avque	r+w/s	blks/s	avwait	avserv
12:44:18	export/home	0	0.0	0	0	0.0	0.0
	export/home	0	0.0	0	0	0.0	0.0
	export/home	0	0.0	0	0	0.0	0.0
	export/home	0	0.0	0	0	0.0	0.0
	export/home	0	0.0	0	0	0.0	0.0
	id20	0	0.0	0	0	0.0	0.0
	export/home	0	0.0	0	0	0.0	0.0
	export/home	0	0.0	0	0	0.0	0.0
	export/home	0	0.0	0	0	0.0	0.0
	export/home	0	0.0	0	0	0.0	0.0
	export/home	0	0.0	0	0	0.0	0.0
	export/home	0	0.0	0	0	0.0	0.0
	export/home	0	0.0	0	0	0.0	0.0
	export/home	0	0.0	0	0	0.0	0.0
	var/mail	0	0.0	0	0	0.0	0.0
	export/home	0	0.0	0	0	0.0	0.0
	sd15	7	0.1	4	127	0.0	17.6
	sd16	6	0.1	3	174	0.0	21.6
	sd17	5	0.0	3	127	0.0	15.5

In the `sar -d` option reports the activities of the disk devices. The 15 means that data is collected every 15 seconds. The 1000 means that data is collected 1000 times. The following terms and abbreviations explain the output.

**TABLE 3-6** Output of the `sar -d 15 1000 | d2fs.server` Command

<code>device</code>	Name of the disk device being monitored
<code>%busy</code>	Percentage of time the device spent servicing a transfer request (same as <code>iostat %b</code> )
<code>avque</code>	Average number of requests outstanding during the monitored period (measured only when the queue was occupied) (same as <code>iostat actv</code> )
<code>r+w/s</code>	Number of read and write transfers to the device, per second (same as <code>iostat r/s + w/s</code> )
<code>blks/s</code>	Number of 512-byte blocks transferred to the device, per second (same as <code>iostat 2*(Kr/s + Kw/s)</code> )
<code>await</code>	Average time, in milliseconds, that transfer requests wait in the queue (measured only when the queue is occupied) ( <code>iostat wait</code> gives the length of this queue)
<code>avserv</code>	Average time, in milliseconds, for a transfer request to be completed by the device (for disks, this includes seek, rotational latency, and data transfer times)

**d. For file systems that are exported via NFS, check the `%b/%busy` value.**

If it is more than 30 percent, check the `svc_t` value.

The `%b` value, the percentage of time the disk is busy, is returned by the `iostat` command. The `%busy` value, the percentage of time the device spent servicing a transfer request, is returned by the `sar` command. If the `%b` and the `%busy` values are greater than 30 percent, go to Step e. Otherwise, go to Step 9.

**e. Calculate the `svc_t/(avserv + await)` value.**

The `svc_t` value, the average service time in milliseconds, is returned by the `iostat` command. The `avserv` value, the average time (milliseconds) for a transfer request to be completed by the device, is returned by the `sar` command. Add the `await` to get the same measure as `svc_t`.

If the `svc_t` value, the average total service time in milliseconds, is more than 40 ms, the disk is taking a long time to respond. An NFS request with disk I/O will appear to be slow by the NFS clients. The NFS response time should be less than 50 ms on average, to allow for NFS protocol processing and network transmission time. The disk response should be less than 40 ms.

The average service time in milliseconds is a function of the disk. If you have fast disks, the average service time should be less if you have slow disks.

**9. Collect data on a regular basis by uncommenting the lines in the user's sys crontab file so that sar collects the data for one month.**

Performance data will be continuously collected to provide a history of sar results.

```
root# crontab -l sys
#ident"@(#)sys1.592/07/14 SMI"/* SVr4.0 1.2*/
#
# The sys crontab should be used to do performance collection.
# See cron and performance manual pages for details on startup.
0 * * * 0-6 /usr/lib/sa/sa1
20,40 8-17 * * 1-5 /usr/lib/sa/sa1
5 18 * * 1-5 /usr/lib/sa/sa2 -s 8:00 -e 18:01 -i 1200 -A
```

Performance data is continuously collected to provide you with a history of sar results.

---

**Note** – A few hundred Kbytes will be used at most in /var/adm/sa.

---

**10. Spread the load over the disks.**

Stripe the file system over multiple disks if the disks are overloaded using Solstice™ DiskSuite or Online: DiskSuite. Reduce the number of accesses and spread peak access loads out in time using a Prestoserve write cache (see “Using Solstice DiskSuite or Online: DiskSuite to Spread Disk Access Load” on page 70 in Chapter 4.)

**11. Adjust the buffer cache if you have read-only file systems (see “Adjusting the Buffer Cache (bufhwm)” on page 80 in Chapter 4.**

**12. Display server statistics to identify NFS problems by typing `nfsstat -s`.**

The `-s` option displays server statistics.

```
server% nfsstat -s
Server rpc:
calls      badcalls   nullrecv   badlen     xdrcall
480421    0          0          0          0
Server nfs:
calls      badcalls
480421    2
null      getattr   setattr   root       lookup    readlink  read
95 0%    140354 29% 10782 2% 0 0%    110489 23% 286 0%    63095 13%
wrcache   write     create    remove     rename    link      symlink
0 0%     139865 29% 7188 1% 2140 0%  91 0%    19 0%    231 0%
mkdir     rmdir     readdir   statfs
435 0%    127 0%   2514 1%  2710 1%
```

The NFS server display shows the number of NFS calls received (`calls`) and rejected (`badcalls`), and the counts and percentages for the various calls that were made. The number and percentage of calls returned by the `nfsstat -s` command are shown in the following table.

The following terms explain the output of the `nfsstat -s` command.

**TABLE 3-7** Description of the Output of the `nfsstat -s` Command

<code>calls</code>	Total number of RPC calls received
<code>badcalls</code>	Total number of calls rejected by the RPC layer (the sum of <code>badlen</code> and <code>xdrcall</code> )
<code>nullrecv</code>	Number of times an RPC call was not available when it was thought to be received
<code>badlen</code>	Number of RPC calls with a length shorter than a minimum-sized RPC call
<code>xdrcall</code>	Number of RPC calls whose header could not be XDR decoded

TABLE 3-8 explains the `nfsstat -s` command output and what actions to take.

**TABLE 3-8** Description of the `nfsstat -s` Command Output

If	Then
writes > 5%**	Install a Prestoserve NFS accelerator (SBus card or NVRAM-NVSIMM) for peak performance. See “Prestoserve NFS Accelerator” on page 76 in Chapter 4.
There are any badcalls	Badcalls are calls rejected by the RPC layer and are the sum of badlen and xdr call. The network may be overloaded. Identify an overloaded network using network interface statistics.
readlink > 10% of total lookup calls on NFS servers	NFS clients are using excessive symbolic links that are on the file systems exported by the server. Replace the symbolic link with a directory. Mount both the underlying file system and the symbolic link’s target on the NFS client. See Step 11.
getattr > 40%	Increase the client attribute cache using the <code>actimeo</code> option. Make sure that the DNLC and inode caches are large. Use <code>vmstat -s</code> to determine the percent hit rate (cache hits) for the DNLC and, if needed, increase <code>ncsize</code> in the <code>/etc/system</code> file. See Step 12 later in this chapter and “Directory Name Lookup Cache (DNLC)” on page 82 in Chapter 4.

\*\* The number of writes, 29% is very high.

### 13. Eliminate symbolic links.

If `symlink` is greater than ten percent in the output of the `nfsstat -s` command, eliminate symbolic links. In the following example,

`/usr/tools/dist/sun4` is a symbolic link for `/usr/dist/bin`.

- a. Type `rm /usr/dist/bin` to eliminate the symbolic link for `/usr/dist/bin`.

```
# rm /usr/dist/bin
```

- b. Make `/usr/dist/bin` a directory by typing `mkdir /usr/dist/bin`.

```
# mkdir /usr/dist/bin
```

**c. Mount the directories and type the following:**

```
client# mount server: /usr/dist/bin
client# mount server: /usr/tools/dist/sun4
client# mount
```

**14. View the Directory Name Lookup Cache (DNLC) hit rate by typing `vmstat -s`.**

This command returns the hit rate (cache hits).

```
% vmstat -s
... lines omitted
79062 total name lookups (cache hits 94%)
16 toolong
```

**a. If the hit rate is less than 90 percent and there is no problem with the number of longnames, increase the `nsize` variable in the `/etc/system` file by typing:**

```
set nsize=5000
```

Directory names less than 30 characters long are cached and names that are too long to be cached are also reported.

The default value of `nsize` is: `nsize (name cache) = 17 * maxusers + 90`

- For NFS server benchmarks `nsize` has been set as high as 16000.
- For `maxusers = 2048` `nsize` would be set at 34906.

For more information on the Directory Name Lookup Cache, see “Directory Name Lookup Cache (DNLC)” on page 82 in Chapter 4.

**b. Reboot the system.**

**15. Check the system state if the system has a Prestoserve NFS accelerator by typing `/usr/sbin/presto`. Verify that it is in the UP state.**

```
server% /usr/sbin/presto
state = UP, size = 0xfff80 bytes
statistics interval: 1 day, 23:17:50 (170270 seconds)
write cache efficiency: 65%
All 2 batteries are ok
```

- If it is in the DOWN state, type `presto -u`.

```
server% presto -u
```

- If it is in the error state, see the *Prestoserve User's Guide*.

This completes the steps you use to check the server. Continue by checking each client.

## Checking Each Client

The overall tuning process must include client tuning. Sometimes, tuning the client yields more improvement than fixing the server. For example, adding 4 Mbytes of memory to each of 100 clients dramatically decreases the load on an NFS server.

### ▼ To Check Each Client

1. Check the client statistics for NFS problems by typing `nfsstat -c` at the `%` prompt.

Look for errors and retransmits.

```
client % nfsstat -c
Client rpc:
calls      badcalls  retrans   badxids   timeouts  waits     newcreds
384687     1         52        7         52        0         0
badverfs   timers    toobig    nomem     cantsend  buflocks
0          384       0         0         0         0
Client nfs:
calls      badcalls  clgets    cltoomany
379496     0         379558    0
Version 2: (379599 calls)
null      getattr   setattr   root      lookup    readlink  read
0 0%      178150 46% 614 0%   0 0%      39852 10% 28 0%     89617 23%
wrcache   write     create    remove    rename    link      symlink
0 0%      56078 14% 1183 0%   1175 0%   71 0%     51 0%     0 0%
mkdir     rmdir    readdir   statfs
49 0%     0 0%     987 0%   11744 3%
```

The output of the `nfsstat -c` command shows that there were only 52 retransmits (`retrans`) and 52 time-outs (`timeout`) out of 384687 calls.



The `nfsstat -c` display contains the following fields:

**TABLE 3-9** Output of the `nfsstat -c` Command

<code>calls</code>	Total number of calls sent
<code>badcalls</code>	Total number of calls rejected by RPC
<code>retrans</code>	Total number of retransmissions
<code>badxid</code>	Number of times that a duplicate acknowledgment was received for a single NFS request
<code>timeout</code>	Number of calls that timed out
<code>wait</code>	Number of times a call had to wait because no client handle was available
<code>newcred</code>	Number of times the authentication information had to be refreshed

TABLE 3-9, shown earlier in this chapter, describes the NFS operations. TABLE 3-10 explains the output of the `nfsstat -c` command and what action to take.

**TABLE 3-10** Description of the `nfsstat -c` Command Output

If	Then
<code>retrans &gt; 5%</code> of the calls	The requests are not reaching the server.
<code>badxid</code> is approximately equal to <code>badcalls</code>	The network is slow. Consider installing a faster network or installing subnets.
<code>badxid</code> is approximately equal to <code>timeouts</code>	Most requests are reaching the server but the server is slower than expected. Watch expected times using <code>nfsstat -m</code> .
<code>badxid</code> is close to 0	The network is dropping requests. Reduce <code>rsize</code> and <code>wsize</code> in the mount options.
<code>null &gt; 0</code>	A large amount of <code>null</code> calls suggests that the automounter is retrying the mount frequently. The timeout values for the mount are too short. Increase the mount timeout parameter, <code>timeo</code> , on the automounter command line

The third-party tools you can use for NFS and networks include:

- NetMetrix (Hewlett-Packard)
- SharpShooter (Network General)

**2. Display statistics for each NFS mounted file system by typing `nfsstat -m`.**

The statistics include the server name and address, mount flags, current read and write sizes, transmission count, and the timers used for dynamic transmission.

```
client % nfsstat -m
/export/home from server:/export/home
Flags:
vers=2,hard,intr,dynamic,rsize=8192,wsiz=8192,retrans=5
Lookups: srtt=10 (25ms), dev=4 (20ms), cur=3 (60ms)
Reads:   srtt=9 (22ms), dev=7 (35ms), cur=4 (80ms)
Writes:  srtt=7 (17ms), dev=3 (15ms), cur=2 (40ms)
All:     srtt=11 (27ms), dev=4 (20ms), cur=3 (60ms)
```

Descriptions of the following terms, used in the output of the `nfsstat -m` command, follow:

**TABLE 3-11** Description of the Output of the `nfsstat -m` Command

srtt	Smoothed round-trip time
dev	Estimated deviation
cur	Current backed-off timeout value

The numbers in parentheses in the previous code example are the actual times in milliseconds. The other values are unscaled values kept by the operating system kernel. You can ignore the unscaled values. Response times are shown for lookups, reads, writes, and a combination of all of these operations (all). TABLE 3-12 shows the appropriate action for the `nfsstat -m` command.

**TABLE 3-12** Results of the `nfsstat -m` Command

If	Then
srtt > 50 ms	That mount point is slow. Check the network and the server for the disk(s) that provide that mount point. See “To Check the Network” and “To Check the NFS Server” earlier in this chapter.
The message “NFS server not responding” is displayed	Try increasing the <code>timeo</code> parameter in the <code>/etc/vfstab</code> file to eliminate the messages and improve performance. Doubling the initial <code>timeo</code> parameter value is a good baseline.  After changing the <code>timeo</code> value in the <code>vfstab</code> file, invoke the <code>nfsstat -c</code> command and observe the <code>badxid</code> value returned by the command. Follow the recommendations for the <code>nfsstat -c</code> command earlier in this section.
Lookups: cur > 80 ms	The requests are taking too long to process. This indicates a slow network or a slow server.
Reads: cur > 150 ms	The requests are taking too long to process. This indicates a slow network or a slow server.
Writes: cur > 250 ms	The requests are taking too long to process. This indicates a slow network or a slow server.



# Configuring the Server and the Client to Maximize NFS Performance

---

This chapter provides configuration recommendations to maximize NFS performance. For troubleshooting tips see Chapter 5.

---

## Tuning to Improve NFS Performance

This chapter discusses tuning recommendations for these environments:

- Attribute-intensive environments, in which primarily small files (one to two hundred bytes) are accessed. Software development is an example of an attribute-intensive environment.
- Data-intensive environments, in which primarily large files are accessed. A *large* file can be defined as a file that takes one or more seconds to transfer (roughly 1 Mbyte). CAD or CAE are examples of data-intensive environments.

Check these items when tuning the system:

- Networks
- Disk drives
- Central processor units
- Memory
- Swap space
- Number of NFS threads in `/etc/init.d/nfs.server`
- `/etc/system` to modify kernel variables

Once you have profiled the performance capabilities of your server, begin tuning the system. Tuning an NFS server requires a basic understanding of how networks, disk drives, CPUs, and memory affect performance. To tune the system, determine which parameters need adjusting to improve balance.

## ▼ To Monitor and Tune Server Performance

1. **Collect statistics. See Chapter 3.**
2. **Identify a constraint or overutilized resource and reconfigure around it.**  
Refer to this chapter and Chapter 3 for tuning recommendations.
3. **Measure the performance gain over a long evaluation period.**

## Balancing NFS Server Workload

All NFS processing takes place inside the operating system kernel at a higher priority than user-level tasks.

---

**Note** – Do not combine databases or time-shared loads on an NFS server because when the NFS load is high any additional tasks performed by an NFS server will run slowly.

---

Non-interactive workloads such as mail delivery and printing, excluding the SPARCprinter (not supported in the Solaris 2.6 and later releases of the Solaris operating environment) or other Sun printers based on the NeWSprint™ software are good candidates for using the server for dual purpose (such as NFS and other tasks). If you have spare CPU power and a light NFS load, then interactive work will run normally.

---

## Networking Requirements

Providing sufficient network bandwidth and availability is the most important configuration for NFS servers. This means that you should configure the appropriate number and type of networks and interfaces.

Follow these tips when setting up and configuring the network.

- Make sure that network traffic is well balanced across all client networks and that networks are not overloaded.
- If one client network is excessively loaded, watch the NFS traffic on that segment.
  1. Identify the hosts that are making the largest demands on the servers.
  2. Partition the work load or move clients from one segment to another.

Simply adding disks to a system does not improve its NFS performance unless the system is truly disk I/O-bound. The network itself is likely to be the constraint as the file server increases in size, requiring the addition of more network interfaces to keep the system in balance.

Instead of attempting to move more data blocks over a single network, consider characterizing the amount of data consumed by a typical client and balance the NFS reads and writes over multiple networks.

## Data-Intensive Applications

Data-intensive applications demand relatively few networks. However, the networks must be of high-bandwidth.

If your configuration has either of the following characteristics, then your applications require high-speed networking:

- Your clients require aggregate data rates of more than 1 Mbyte per second.
- More than one client must be able to simultaneously consume 1 Mbyte per second of network bandwidth.

## Configuring the Network When the Primary Application of Your Server Is Data-Intensive

- Configure FDDI, SunATM™, or another high-speed network.

If fiber cabling can't be used for logistical reasons, consider FDDI, CDDI, or SunFastEthernet™ over twisted-pair implementations. SunATM uses the same size fiber cabling as FDDI. For more information on FDDI, see the *FDDI/S3.0 User's Guide*.

- Configure one FDDI ring for each five to seven concurrent fully NFS-active clients.

Few data-intensive applications make continuous NFS demands. In typical data-intensive EDA and earth-resources applications, this results in 25-40 clients per ring.

A typical use consists of loading a big block of data that is manipulated then written back to the server. Because the data is written back, these environments can have very high write percentages.

- If your installation has Ethernet cabling, configure one Ethernet for every two active clients.

This almost always requires a SPARCserver 1000, SPARCserver 1000E, SPARCcenter 2000, SPARCcenter 2000E system, or an Ultra Enterprise 3000, 4000, 5000, or 6000 system since useful communities require many networks. Configure a maximum of four to six clients per network.

## Attribute-Intensive Applications

In contrast, most attribute-intensive applications are easily handled with less expensive networks. However, attribute-intensive applications require many networks. Use lower-speed networking media, such as Ethernet or Token Ring.

To configure networking when the primary application of the server is attribute-intensive:

- Configure on Ethernet or Token Ring.
- Configure one Ethernet network for eight to ten fully active clients.

More than 20 to 25 clients per Ethernet results in severe degradation when many clients are active. As a check, an Ethernet can sustain about 250-300 NFS ops/second on the SPECnfs\_097 (LADDIS) benchmark, albeit at high collision rates. It is unwise to exceed 200 NFS ops/second on a sustained basis.

- Configure one Token Ring network for each ten to fifteen active clients.

If necessary, 50 to 80 total clients per network are feasible on Token Ring networks, due to their superior degradation characteristics under heavy load (compared to Ethernet).

## Systems with More Than One Class of Users

Mixing network types is not unreasonable. For example, both FDDI and Token Ring are appropriate for a server that supports both a document imaging application (data-intensive) and a group of PCs running a financial analysis application (most likely attribute-intensive).

The platform you choose is often dictated by the type and number of networks, as they may require many network interface cards.



- **To configure networking for servers that have more than one class of users, mix network types.**

---

## Disk Drives

Disk drive usage is frequently the tightest constraint in an NFS server. Even a sufficiently large memory configuration may not improve performance if the cache cannot be filled quickly enough from the file systems.

### Determining if Disks Are the Bottleneck

- **Use `iostat` to determine disk usage.**

Look at the number of read and write operations per second (see “Checking the NFS Server” on page 42” in Chapter 3).

Because there is little dependence in the stream of NFS requests, the disk activity generated contains large numbers of random access disk operations. The maximum number of random I/O operations per second ranges from 40-90 per disk.

Driving a single disk at more than 60 percent of its random I/O capacity creates a disk bottleneck.

### Limiting Disk Bottlenecks

Disk bandwidth on an NFS server has the greatest effect on NFS client performance. Providing sufficient bandwidth and memory for file system caching is crucial to providing the best possible file server performance. Note that read/write latency is also important. For example, each NFSop may involve one or more disk accesses. Disk service times add to the NFSop latency, so slow disks mean a slow NFS server.

Follow these guidelines to ease disk bottlenecks:

- Balance the I/O load across all disks on the system.

If one disk is heavily loaded and others are operating at the low end of their capacity, shuffle directories or frequently accessed files to less busy disks.

- Partition the file system(s) on the heavily used disk and spread the file system(s) over several disks.

Adding disks provides additional disk capacity and disk I/O bandwidth.

- Replicate the file system to provide more network-to-disk bandwidth for the clients if the file system used is read-only by the NFS clients, and contains data that doesn't change constantly.

See the following section, "Replicating File Systems."

- Size the operating system caches correctly, so that frequently needed file system data may be found in memory.

Caches for inodes (file information nodes), file system metadata such as cylinder group information, and name-to-inode translations must be sufficiently large, or additional disk traffic is created on cache misses. For example, if an NFS client opens a file, that operation generates several name-to-inode translations on the NFS server.

If an operation misses the Directory Name Lookup Cache (DNLC), the server must search the disk-based directory entries to locate the appropriate entry name. What would nominally be a memory-based operation degrades into several disk operations. Also, cached pages will not be associated with the file.

## Replicating File Systems

Commonly used file systems, such as the following, are frequently the most heavily used file systems on an NFS server:

- `/usr` directory for diskless clients
- Local tools and libraries
- Third-party packages
- Read-only source code archives

The best way to improve performance for these file systems is to replicate them. One NFS server is limited by disk bandwidth when handling requests for only one file system. Replicating the data increases the size of the aggregate "pipe" from NFS clients to the data. However, replication is *not* a viable strategy for improving performance with writable data, such as a file system of home directories. Use replication with read-only data.

To replicate file systems, do the following:

- Identify the file or file systems to be replicated.
- If several individual files are candidates, consider merging them in a single file system. The potential decrease in performance that arises from combining heavily used files on one disk is more than offset by performance gains through replication.
- Use `nfswatch`, to identify the most commonly used files and file systems in a group of NFS servers. TABLE A-1 in Appendix A lists performance monitoring tools, including `nfswatch`, and explains how to obtain `nfswatch`.
- Determine how clients will choose a replica.

Specify a server name in the `/etc/vfstab` file to create a permanent binding from NFS client to the server. Alternatively, listing all server names in an automounter map entry allows completely dynamic binding, but may also lead to a client imbalance on some NFS servers. Enforcing “workgroup” partitions in which groups of clients have their own replicated NFS server strikes a middle ground between the extremes and often provides the most predictable performance.

- Choose an update schedule and method for distributing the new data.

The frequency of change of the read-only data determines the schedule and the method for distributing the new data. File systems that undergo a complete change in contents, for example, a flat file with historical data that is updated monthly, can be best handled by copying data from the distribution media on each machine, or using a combination of `ufsdump` and `restore`. File systems with few changes can be handled using management tools such as `rdist`.

- Evaluate what penalties, if any, are involved if users access old data on a replica that is not current. One possible way of doing this is with the Solaris 2.x JumpStart™ facilities in combination with `cron`.

## Adding the Cache File System

The cache file system is client-centered. You use the cache file system on the client to reduce server load. With the cache file system, files are obtained from the server, block by block. The files are sent to the memory of the client and manipulated directly. Data is written back to the disk of the server.

Adding the cache file system to client mounts provides a local replica for each client. The `/etc/vfstab` entry for the cache file system looks like this:

```
# device    device    mount    FS    fsck    mount    mount
# to mount to fsck   point    type  pass   at boot  options
server:/usr/dist    cache    /usr/dist    cachefs 3  yes
ro,backfstype=nfs,cachedir=/cache
```

Use the cache file system in situations with file systems that are read mainly, such as application file systems. Also, you should use the cache file system for sharing data across slow networks. Unlike a replicated server, the cache file system can be used with writable file systems, but performance will degrade as the percent of writes climb. If the percent of writes is too high, the cache file system may decrease NFS performance.

You should also consider using the cache file system if your networks are high speed networks interconnected by routers.

If the NFS server is frequently updated, do not use the cache file system because doing so would result in more traffic than operating over NFS.

- **To monitor the effectiveness of the cached file systems use the `cachefsstat` command (available with the Solaris 2.5 and later operating environment).**

The syntax of the `cachefsstat` command is as follows:

```
system# /usr/bin/cachefsstat [-z] path
```

where:

`-z` initializes statistics. You should execute `cachefs -z` (superuser only) before executing `cachefsstat` again to gather statistics on the cache performance. The statistics printed reflect those just before the statistics are reinitialized.

`path` is the path the cache file system is mounted on. If you do not specify a path, all mounted cache file systems are used.

Without the `-z` option, you can execute this command as a regular UNIX user. The statistical information supplied by the `cachefsstat` command includes cache hits and misses, consistency checking, and modification operation:

**TABLE 4-1** Statistical Information Supplied by the `cachefsstat` Command

Output	Description
cache hit rate	Percentage of cache hits over the total number of attempts (followed by the actual numbers of hits and misses)
consistency checks	Number of consistency checks performed. It is followed by the number that passed and the number that failed.
modifies	Number of modify operations, including writes and creates.

An example of the `cachefsstat` command is:

```
system% /usr/bin/cachefsstat /home/sam
cache hit rate: 73% (1234 hits, 450 misses)
consistency checks: 700 (650 pass, 50 fail)
modifies: 321
```

In the previous example, the cache hit rate for the file system should be higher than thirty percent. If the cache hit rate is lower than thirty percent, this means that the access pattern on the file system is widely randomized or that the cache is too small.

The output for a consistency check means that the cache file system checks with the server to see if data is still valid. A high failure rate (15 to 20 percent) means that the data of interest is rapidly changing. The cache may be updated more quickly than

what is appropriate for a cached file system. When you use the output from consistency checks with the number of modifies, you can learn if this client or other clients are making the changes.

The output for modifies is the number of times the client has written changes to the file system. This output is another method to understand why the hit rate may be low. A high rate of modify operations likely goes along with a high number of consistency checks and a lower hit rate.

Also available, beginning with the Solaris 2.5 software environment, are the commands `cachefswwsize`, which determine the working set size for the cache file system and `cachefsstat`, which displays where the cache file system statistics are being logged. Use these commands to determine if the cache file system is appropriate and valuable for your installation.

## Configuration Rules for Disk Drives

Follow these general guidelines for configuring disk drives. In addition to the following general guidelines, more specific guidelines for configuring disk drives in data-intensive environments and attribute-intensive environments follows:

- Configure additional drives on each host adapter without degrading performance (as long as the number of active drives does not exceed SCSI standard guidelines).
- Use Online: DiskSuite or Solstice DiskSuite to spread disk access load across many disks. See “Using Solstice DiskSuite or Online: DiskSuite to Spread Disk Access Load” later in this chapter.
- Use the fastest zones of the disk when possible. See “Using the Optimum Zones of the Disk” later in this chapter.

Keep these rules in mind when configuring disk drives in data-intensive environments:

- Configure for a sequential environment.
- Use disks with the fastest transfer speeds (preferably in stripes).
- Configure one RAID device (logical volume or metadisk) for every three active version 3 clients or one device for every four to five version 2 clients.
- Configure one drive for every client on Ethernet or Token Ring.

When configuring disk drives in attribute-intensive environments:

- Configure with a larger number of smaller disks, which are connected to a moderate number of SCSI host adapters (such as a disk array).
- Configure four to five (or up to eight or nine) fully active disks per fast SCSI host adapter. Using smaller disk drives is much better than operating with one large disk drive.

- Configure at least one disk drive for every two fully active clients (on any type of network.)
- Configure no more than eight to ten fully active disk drives for each fast/wide SCSI host adapter.

## Using Solstice DiskSuite or Online: DiskSuite to Spread Disk Access Load

A common problem in NFS servers is poor load balancing across disk drives and disk controllers.

To balance loads, do the following:

- Balance loads by physical usage instead of logical usage. Use Solstice DiskSuite or Online: DiskSuite to spread disk access across disk drives transparently by using its striping and mirroring functions.

The disk mirroring feature of Solstice DiskSuite or Online: DiskSuite improves disk access time and reduces disk usage by providing access to two or three copies of the same data. This is particularly true in environments dominated by read operations. Write operations are normally slower on a mirrored disk since two or three writes must be accomplished for each logical operation requested.

- Balance loads using disk concatenation when disks are relatively full. This procedure accomplishes a minimum amount of load balancing
- If your environment is data-intensive, stripe the disk with a small interlace to improve disk throughput and distribute the service load. Disk striping improves read and write performance for serial applications. Use 64 Kbytes per number of disks in the stripe as a starting point for interlace size.
- If your environment is attribute-intensive, where random access dominates disk usage, stripe the disk with the default interlace (one disk cylinder).
- Use the `iostat` and `sar` commands to report disk drive usage.

Attaining even disk usage usually requires some iterations of monitoring and data reorganization. In addition, usage patterns change over time. A data layout that works when installed may perform poorly a year later. For more information on checking disk drive usage, see “Checking the NFS Server” on page 42 in Chapter 3.

# Using Log-Based File Systems With Solstice DiskSuite or Online: DiskSuite 3.0

The Solaris 2.4 through Solaris 7 software environments and the Online: Disk Suite 3.0 or Solstice DiskSuite software support a log-based extension to the standard UNIX file system, which works like a disk-based Prestoserve NFS accelerator.

In addition to the main file system disk, a small (typically 10 Mbytes) section of disk is used as a sequential log for writes. This speeds up the same kind of operations as a Prestoserve NFS accelerator with two advantages:

- In dual-machine high-available configurations, the Prestoserve NFS accelerator cannot be used. The log can be shared so that it can be used.
- After an operating system crash, the `fsck` of the log-based file system involves a sequential read of the log only. The sequential read of the log is almost instantaneous, even on very large file systems.

---

**Note** – You cannot use the Prestoserve NFS accelerator and the log on the same file system.

---

## Using the Optimum Zones of the Disk

When you analyze your disk data layout, consider *zone bit recording*.

All of Sun's current disks (except the 207 Mbyte disk) use this type of encoding which uses the peculiar geometric properties of a spinning disk to pack more data into the parts of the platter closest to its edge. This results in the lower disk addresses (corresponding to the outside cylinders) usually outperforming the inside addresses by 50 percent.

- **Put the data in the lowest-numbered cylinders.**

The zone bit recording data layout makes those cylinders the fastest ones.

This margin is most often realized in serial transfer performance, but also affects random access I/O. Data on the outside cylinders (zero) not only moves past the read/write heads more quickly, but the cylinders are also larger. Data will be spread over fewer large cylinders, resulting in fewer and shorter seeks.

---

# Central Processor Units

This section explains how to determine CPU usage and provides guidelines for configuring CPUs in NFS servers.

## Determining CPU Usage

- To get 30 second averages, type `mpstat 30` at the `%` prompt.

The following screen is displayed:

```
system% mpstat 30
CPU minf mjf xcal  intr ithr  csw icsw migr smtx  srw syscl  usr sys  wt idl
 0    6  0  0   114  14   25  0    6   3    0   48   1  2  25  72
 1    6  0  0    86  85   50  0    6   3    0   66   1  4  24  71
 2    7  0  0    42  42   31  0    6   3    0   54   1  3  24  72
 3    8  0  0     0   0   33  0    6   4    0   54   1  3  24  72
```

The `mpstat 30` command reports statistics per processor. Each row of the table represents the activity of one processor. The first table summarizes all activities since the system was last booted. Each subsequent table summarizes activity for the preceding interval. All values are rates (events per second).

Review the following data in the `mpstat` output (see Table 4-2):

**TABLE 4-2** Output of the `mpstat` Command

---

<code>usr</code>	Percent user time
<code>sys</code>	Percent system time (can be caused by NFS processing)
<code>wt</code>	Percent wait time (treat as for idle time)
<code>idl</code>	Percent idle time

---

If `sys` is greater than 50 percent, increase CPU power to improve NFS performance.



Table 4-2 describes guidelines for configuring CPUs in NFS servers.

**TABLE 4-3** Guidelines for Configuring CPUs in NFS Servers

If	Then
Your environment is predominantly attribute-intensive, and you have one to three medium-speed Ethernet or Token Ring networks.	A uniprocessor system is sufficient. For smaller systems, the UltraServer 1, SPARCserver 2, or SPARCserver 5 systems have sufficient processor power.
Your environment is predominantly attribute-intensive and you have between 4 to 60 medium-speed Ethernet or Token Ring networks.	Use an UltraServer 2, SPARCserver 10, or SPARCserver 20 system.
You have larger attribute-intensive environments and SBUS and disk expansion capacity is sufficient.	Use multiprocessor models of the UltraServer 2, SPARCserver 10 or the SPARCserver 20 systems.
You have larger attribute-intensive environments.	Use dual-processor systems such as: <ul style="list-style-type: none"><li>- SPARCserver 10 system Model 512</li><li>- SPARCserver 20 system</li><li>- SPARCserver 1000 or 1000E system</li><li>- Ultra Enterprise 3000, 4000, 5000, or 6000 system</li><li>- SPARCcenter 2000/2000E system</li></ul> Either the 40 MHz/1Mbyte or the 50MHz/2 Mbyte module work well for an NFS work load in the SPARCcenter 2000 system. You will get better performance from the 50 MHz/2Mbyte module.
Your environment is data-intensive and you have a high-speed network.	Configure one SuperSPARC processor per high-speed network (such as FDDI).
Your environment is data-intensive and you must use an Ethernet connection due to cabling restrictions.	Configure one SuperSPARC processor for every four Ethernet or Token Ring networks.
Your environment is a pure NFS installation.	You do not need to configure additional processors beyond the recommended number on your server(s).
Your servers perform tasks in addition to NFS processing.	Add additional processors to increase performance significantly.

## Memory

Since NFS is a disk I/O-intensive service, a slow server can suffer from I/O bottlenecks. Adding memory eliminates the I/O bottleneck by increasing the file system cache size.

The system could be waiting for file system pages, or it may be paging process images to and from the swap device. The latter effect is only a problem if additional services are provided by the system, since NFS service runs entirely in the operating system kernel.

If the swap device is not showing any I/O activity, then all paging is due to file I/O operations from NFS reads, writes, attributes, and lookups.

## Determining if an NFS Server Is Memory Bound

Paging file system data from the disk into memory is a more common NFS server performance problem.

### ▼ To Determine if the Server Is Memory Bound

#### 1. Watch the scan rate reported by `vmstat 30`.

If the scan rate (`sr`, the number of pages scanned) is often over 200 pages/second, then the system is short of memory (RAM). The system is trying to find unused pages to be reused and may be reusing pages that should be cached for rereading by NFS clients.

#### 2. Add memory.

Adding memory eliminates repeated reads of the same data and enables the NFS requests to be satisfied out of the page cache of the server. To calculate the memory required for your NFS server, see “Calculating Memory,” which follows.

The memory capacity required for optimal performance depends on the average working set size of files used on that server. The memory acts as a cache for recently read files. The most efficient cache matches the current working set size as closely as possible.

Because of this memory caching feature, it is not unusual for the free memory in NFS servers to be between 0.5 Mbytes to 1.0 Mbytes if the server has been active for a long time. Such activity is normal and desirable. Having enough memory allows you to service multiple requests without blocking.

The actual files in the working set may change over time. However, the size of the working set may remain relatively constant. NFS creates a *sliding window* of active files, with many files entering and leaving the working set throughout a typical monitoring period.

# Calculating Memory

You can calculate memory according to general or specific memory rules.

## General Memory Rules

Follow these general guidelines to calculate the amount of memory you will need.

- Virtual memory = RAM (main memory) + swap space
- Calculate the amount of memory according to the five-minute rule:

Memory is sized at 16 Mbytes plus memory to cache the data, which will be accessed more often than once in five minutes.

## Specific Memory Rules

Follow these specific guidelines to calculate the amount of memory you will need.

- If your server primarily provides user data for many clients, configure relatively minimal memory.

For small installations, this will be 32 Mbytes; for large installations, this will be about 128 Mbytes. In multiprocessor configurations, provide at least 64 Mbytes per processor. Attribute-intensive applications normally benefit slightly more from memory than data-intensive applications.

- If your server normally provides temporary file space for applications that use those files heavily, configure your server memory to about 75 percent of the size of the active temporary files in use on the server.

For example, if each client's temporary file is about 5 Mbytes, and the server is expected to handle 20 fully active clients, configure it as follows:

$(20 \text{ clients} \times 5 \text{ Mbytes}) / 75\% = 133 \text{ Mbytes of memory}$

Note that 128 Mbytes is the most appropriate amount of memory that is easily configured.

- If the primary task of your server is to provide only executable images, configure server memory to be equal to approximately the combined size of the heavily-used binary files (including libraries).

For example, a server expected to provide `/usr/openwin` should have enough memory to cache the X server, CommandTool, `libX11.so`, `libview.so` and `libxt`. This NFS application is considerably different from the more typical `/home`, `/src`, or `/data` server in that it normally provides the same files repeatedly to all of its clients and is hence able to effectively cache this data. Clients will not use every page of all of the binaries, which is why it is reasonable to

configure only enough to hold the frequently-used programs and libraries. Use the cache file system on the client, if possible, to reduce the load and RAM needs on the server.

- If the clients are DOS PCs or Macintosh machines, add more RAM cache on the Sun NFS server; these systems do much less caching than UNIX system clients.

## Swap Space

Swap space is almost not needed because NFS servers do not run user processes.

### ▼ To Set Up Swap Space

1. **Configure at least 64 Mbytes virtual memory, which is RAM plus swap space (see Table 4-3).**
2. **Set up fifty percent of main memory as an emergency swap space to save a crash dump in case of a system panic.**

TABLE 4-4 Swap Space Requirements

Amount of RAM	Swap Space Requirements
16 Mbytes	48 Mbytes
32 Mbytes	32 Mbytes
64 or more Mbytes	None

---

## Prestoserve NFS Accelerator

---

**Note** – NFS version 3 reduces the need for Prestoserve™ capability. Using the Prestoserve NFS accelerator makes a significant difference with NFS version 2. The Prestoserve NFS accelerator makes only a slight improvement with NFS version 3.

---

Adding a Prestoserve NFS accelerator with NFS version 2 is another way to improve NFS performance. NFS version 2 requires all writes to be written to stable storage before responding to the operation. The Prestoserve NFS accelerator enables high-speed NVRAM instead of slow disks to meet the stable storage requirement.

Two types of NVRAM used by the Prestoserve NFS accelerator are:

- NVRAM-NVSIMM
- SBus

Both types of Prestoserve NFS accelerators speed up NFS server performance by:

- Providing faster selection of file systems
- Caching writes for synchronous I/O operations
- Intercepting synchronous write requests to disk and storing the data in nonvolatile memory

## NVRAM-NVSIMM

If you can use either NVRAM hardware, use the NVRAM-NVSIMM for the Prestoserve cache. The NVRAM-NVSIMM and SBus hardware are functionally identical. However, the NVRAM-NVSIMM hardware is slightly more efficient and does not require an SBus slot. The NVRAM-NVSIMMs reside in memory and the NVRAM-NVSIMM cache is larger than the SBus hardware.

The NVRAM-NVSIMM Prestoserve NFS accelerator significantly improves the response time of NFS clients with heavily loaded or I/O-bound servers. To improve performance add the NVRAM-NVSIMM Prestoserve NFS accelerator to the following platforms:

- SPARCserver 20 system
- SPARCserver 1000 or 1000E system
- SPARCcenter 2000 or 2000E system

You can use an alternate method for improving NFS performance in Sun Enterprise 3x00, 4x00, 5x00, and 6x00 systems. This method is to upgrade NVRAM in the SPARCstorage Array that is connected to the server.

Sun Enterprise 3x00, 4x00, 5x00, and 6x00 server systems enable SPARCstorage Array NVRAM fast writes. Turn on fast writes by invoking the `ssaadm` command.

## NVRAM SBus

The SBus Prestoserve NFS accelerator contains only a 1 Mbyte cache and resides on the SBus. You can add the SBus Prestoserve NFS accelerator to any SBus-based server except the SPARCserver 1000(E) system, the SPARCcenter 2000(E), or the Sun Enterprise 3x00, 4x00, 5x00, or 6x00 server systems.

Some systems on which you can add the SBus Prestoserve NFS accelerator are:

- SPARCserver 5 system

- SPARCserver 20 system
- Sun Enterprise 1 system
- Sun Enterprise 2 system
- SPARCserver 600 series

---

## Tuning Parameters

This section describes how to set the number of NFS threads. It also covers tuning the main NFS performance-related parameters in the `/etc/system` file. Tune these `/etc/system` parameters carefully, considering the physical memory size of the server and kernel architecture type.

---

**Note** – Arbitrary tuning creates major instability problems, including an inability to boot.

---

### Setting the Number of NFS Threads in `/etc/init.d/nfs.server`

For improved performance, NFS server configurations should set the number of NFS threads. Each thread is capable of processing one NFS request. A larger pool of threads enables the server to handle more NFS requests in parallel. The default setting of 16 in Solaris 2.4 through Solaris 7 software environments results in slower NFS response times. Scale the setting with the number of processors and networks and increase the number of NFS server threads by editing the invocation of `nfsd` in `/etc/init.d/nfs.server`:

```
/usr/lib/nfs/nfsd -a 64
```

The previous code box specifies that the maximum allocation of demand-based NFS threads is 64.

There are three ways to size the number of NFS threads. Each method results in about the same number of threads if you followed the configuration guidelines in this manual. Extra NFS threads do not cause a problem.

To set the number of NFS threads, take the *maximum* of the following three suggestions:

- Use 2 NFS threads for each active client process.

A client workstation usually only has one active process. However, a time-shared system that is an NFS client may have many active processes.

- Use 16 to 32 NFS threads for each CPU.

Use roughly 16 for a SPARCclassic or a SPARCstation 5 system. Use 32 NFS threads for a system with a 60 MHz SuperSPARC processor.

- Use 16 NFS threads for each 10 Mbits of network capacity.

For example, if you have one SunFDDI™ interface, set the number of threads to 160. With two SunFDDI interfaces, set the thread count to 320, and so on.

## Identifying Buffer Sizes and Tuning Variables

The number of fixed-size tables in the kernel has been reduced in each release of the Solaris software environment. Most are now dynamically sized or are linked to the `maxusers` calculation. Extra tuning to increase the DNLC and inode caches is required for the Solaris 2.4 through Solaris 7 software environments. For Solaris version 2.4 you must tune the pager. Tuning the pager is not necessary for Solaris 2.5, 2.5.1, 2.6, or 7 operating environments.

## Using `/etc/system` to Modify Kernel Variables

The `/etc/system` file is read by the operating system kernel at start-up. It configures the search path for loadable operating system kernel modules and enables kernel variables to be set. For more information, see the man page for `system(4)`.



---

**Caution** – Use the set commands in `/etc/system` carefully because the commands in `/etc/system` cause automatic patches of the kernel.

---

If your machine does not boot and you suspect a problem with `/etc/system`, use the `boot -a` option. With this option, the system prompts (with defaults) for its boot parameters. One of these is the `/etc/system` configuration file. Either use the name of a backup copy of the original `/etc/system` file or `/dev/null`. Fix the file and immediately reboot the system to make sure it is operating correctly.

## Adjusting Cache Size: `maxusers`

The `maxusers` parameter determines the size of various kernel tables such as the process table. The `maxusers` parameter is set in the `/etc/system` file. For example:

```
set maxusers = 200
```

In the Solaris 2.4 through Solaris 7 software environments, `maxusers` is dynamically sized based upon the amount of RAM configured in the system. The sizing method used for `maxusers` is:

```
maxusers = Mbytes of RAM configured in the system
```

The number of Mbytes of RAM configured into the system is actually based upon `physmem` which does not include the 2 Mbytes or so that the kernel uses at boot time. The minimum limit is 8 and the maximum automatic limit is 1024, which corresponds to systems with 1 Gbyte or more of RAM. It can still be set manually in `/etc/system` but the manual setting is checked and limited to a maximum of 2048. This is a safe level on all kernel architectures, but uses a large amount of operating system kernel memory.

## Parameters Derived From `maxusers`

Table 4-4 describes the default settings for the performance-related inode cache and name cache operating system kernel parameters.

**TABLE 4-5** Default Settings for Inode and Name Cache Parameters

Kernel Resource	Variable	Default Setting
Inode cache	<code>ufs_ninode</code>	$17 * \text{maxusers} + 90$
Name cache	<code>ncsize</code>	$17 * \text{maxusers} + 90$

## Adjusting the Buffer Cache (`bufhwm`)

The `bufhwm` variable, set in the `/etc/system` file, controls the maximum amount of memory allocated to the buffer cache and is specified in Kbytes. The default value of `bufhwm` is 0, which allows up to 2 percent of system memory to be used. This can be increased up to 20 percent and may need to be increased to 10 percent for a



dedicated NFS file server with a relatively small memory system. On a larger system, the `bufhwm` variable may need to be limited to prevent the system from running out of the operating system kernel virtual address space.

The buffer cache is used to cache inode, indirect block, and cylinder group related disk I/O only. The following is an example of a buffer cache (`bufhwm`) setting in the `/etc/system` file that can handle up to 10 Mbytes of cache. This is the highest value to which you should set `bufhwm`.

```
set bufhwm=10240
```

You can monitor the buffer cache using `sar -b` (see the following code example), which reports a read (`%rcache`) and a write hit rate (`%wcache`) for the buffer cache.

```
# sar -b 5 10
SunOS hostname 5.2 Generic sun4c      08/06/93
23:43:39 bread/s lread/s %rcache bwrit/s lwrit/s %wcache pread/s pwrit/s
Average          0      25      100         3      22         88         0         0
```

If a significant number of reads and writes per second occur (greater than 50) and if the read hit rate (`%rcache`) falls below 90 percent, or if the write hit rate (`%wcache`) falls below 65 percent, increase the buffer cache size, `bufhwm`.

In the previous `sar -b 5 10` command output, the read hit rate (`%rcache`) and the write hit rate (`%wcache`) did not fall below 90 percent or 65 percent respectively.

Following are descriptions of the arguments to the `sar` command.

**TABLE 4-6** Descriptions of the Arguments to the `sar` Command

<code>b</code>	Checks buffer activity
<code>5</code>	Time, every 5 seconds (must be at least 5 seconds)
<code>10</code>	Number of times the command gathers statistics

Your system will prevent you from increasing the buffer cache to an unacceptably high level. Signs of increasing buffer cache size include:

- Hung server
- Device drivers that suffer from a shortage of operating system kernel virtual memory

# Directory Name Lookup Cache (DNLC)

Size the directory name lookup cache (DNLC) to a default value using `maxusers`. A large cache size (`ncsize`) significantly increases the efficiency of NFS servers with multiple clients.

- To show the DNLC hit rate (cache hits), type `vmstat -s`.

```
% vmstat -s
... lines omitted
79062 total name lookups (cache hits 94%)
16 toolong
```

Directory names less than 30 characters long are cached and names that are too long to be cached are also reported. A cache miss means that a disk I/O may be needed to read the directory when traversing the path name components to get to a file. A hit rate of less than 90 percent requires attention.

Cache hit rates can significantly affect NFS performance. `getattr`, `setattr`, and `lookup` usually represent greater than 50 percent of all NFS calls. If the requested information isn't in cache, the request will generate a disk operation that results in a performance penalty as significant as that of a read or write request. The only limit to the size of the DNLC cache is available kernel memory.

If the hit rate (cache hits) is less than 90 percent and a problem does not exist with the number of longnames, tune the `ncsize` variable (see "To Reset `ncsize`," ) which follows. The variable `ncsize` refers to the size of the DNLC in terms of the number of name and vnode translations that can be cached. Each DNLC entry uses about 50 bytes of extra kernel memory.

## ▼ To Reset `ncsize`

- Set `ncsize` in the `/etc/system` file to values higher than the default (based on `maxusers`.)

As an initial guideline, since dedicated NFS servers do not need a lot of RAM, `maxusers` will be low and the DNLC will be small; double its size.

```
set ncsize=5000
```

The default value of `ncsize` is:

`ncsize (name cache) = 17 * maxusers + 90`

- For NFS server benchmarks, set it as high as 16000.

- For `maxusers = 2048`, set it at `34906`.
  - **Reboot the system.**
- See “Increasing the Inode Cache” which follows.

## Increasing the Inode Cache

A memory-resident inode is used whenever an operation is performed on an entity in the file system. The inode read from disk is cached in case it is needed again. `ufs_ninode` is the size that the UNIX file system attempts to keep the list of idle inodes. You can have `ufs_ninod` set to 1 but have 10,000 idle inodes. As active inodes become idle, if the number of idle inodes goes over `ufs_ninode`, then memory is reclaimed by tossing out idle inodes.

Every entry in the DNLC cache points to an entry in the inode cache, so both caches should be sized together. The inode cache should be at least as big as the DNLC cache. For best performance, it should be the same size in the Solaris 2.4 through Solaris 7 operating environments.

Since it is just a limit, `ufs_ninode` you can tweak with `adb` on a running system with immediate effect. The only upper limit is the amount of kernel memory used by the inodes. The tested upper limit corresponds to `maxusers = 2048`, which is the same as `ncsize` at `34906`.

To report the size of the kernel memory allocation use `sar -k`.

- In the Solaris 2.4 operating environment, each inode uses 300 bytes of kernel memory from the `lg_mem` pool.
- In the Solaris 2.5.1, 2.6, and 7 operating environments, each inode uses 320 bytes of kernel memory from the `lg_mem` pool. `ufs_ninode` is automatically adjusted to be at least `ncsize`. Tune `ncsize` to get the hit rate up and let the system pick the default `ufs_ninodes`.

With the Solaris 2.5.1, 2.6, and 7 software environments, `ufs_ninode` is automatically adjusted to be at least `ncsize`. Tune `ncsize` to get the hit rate up and let the system pick the default `ufs_ninodes`.

## Increasing the Inode Cache in the Solaris 2.4 or the 2.5 Operating Environments

If the inode cache hit rate is below 90 percent, or if the DNLC requires tuning for local disk file I/O workloads:

1. **Increase the size of the inode cache.**

2. Change the variable `ufs_ninode` in your `/etc/system` file to the same size as the DNLC (`ncsize`). For example, for the Solaris version 2.4, type:

```
set ufs_ninode=5000
```

The default value of the inode cache is the same as that for `ncsize`:

`ufs_ninode` (default value) =  $17 * \text{maxusers} + 90$ .



---

**Caution** – Do not set `ufs_ninode` less than `ncsize`. The `ufs_ninode` parameter limits the number of inactive inodes, rather than the total number of active and inactive inodes.

---

Reboot the system.

## Increasing Read Throughput

If you are using NFS over a high speed network such as FDDI, SunFastEthernet, or SunATM™, you will have better read throughput by increasing the number of read-aheads on the NFS client.

Increasing read-aheads is *not* recommended under these conditions:

- The client is very short of RAM.
- The network is very busy.
- File accesses are randomly distributed.

When free memory is low, read-ahead will not be performed.

The read-ahead is set to 1 block, by default (8 Kbytes with version 2 and to 32 Kbytes with version 3). For example, a read-ahead set to 2 blocks uses an additional 16 Kbytes from a file while you are reading the first 8 Kbytes from the file. Thus, the read-ahead stays one step ahead of you and uses information in 8 Kbyte increments to stay ahead of the information you need.

Increasing the read-ahead count can improve read throughput up to a point. The optimal read-ahead setting will depend on your configuration and application. Increasing the read-ahead value beyond that setting may actually reduce throughput. In most cases, the optimal read-ahead setting is less than eight read-aheads (8 blocks)..

---

**Note** – In the following procedure you can tune the `nfs_nra` and the `nfs3_nra` values independently.

If a client is running Solaris the 2.5, 2.5.1, 2.6, or 7 operating environment, the client may need to tune `nfs_nra` (NFS version 2). This happens if the client is talking to a server that does not support version 3.

---

## ▼ To Increase the Number of Read-Aheads With Version 2

1. Add the following line to `/etc/system` on the NFS client.

```
set nfs:nfs_nra=4
```

2. Reboot the system to implement the read-ahead value.

## ▼ To Increase the Number of Read-Aheads With Version 3

1. Add the following line to `/etc/system` on the NFS client:

- With versions of the Solaris software environment before the Solaris 2.6 software environment:

```
set nfs:nfs3_nra=6
```

- With the Solaris 2.6 operating environment, type:

```
set nfs:nfs3_nra=2
```

- With the Solaris 7 operating environment type:

```
set nfs:nfs3_nra=4
```

---

**Note** – Raising the read-ahead count too high can make read throughput worse. You may consider running benchmarks with different values of `nfs3_nra` or `nfs_nra` to see what works best in your environment.

---

**2. Reboot the system to implement the read-ahead value.**

# Troubleshooting

---

---

## Troubleshooting Tools

This chapter presents troubleshooting tips for the following types of problems:

- General troubleshooting tuning
- Client bottlenecks
- Server bottlenecks
- Network-related bottlenecks

## General Troubleshooting Tuning Tips

This section (see TABLE 5-1) lists the actions to perform when you encounter a tuning problem.

**TABLE 5-1** General Troubleshooting Tuning Problems and Actions to Perform

Command/Tool	Command Output/Result	Action
<code>netstat -i</code>	<code>Collis+Ierrs+Oerrs/Ipkts + Opkts &gt; 2%</code>	Check the Ethernet hardware.
<code>netstat -i</code>	<code>Collis/Opkts &gt; 10%</code>	Add an Ethernet interface and distribute the client load.

**TABLE 5-1** General Troubleshooting Tuning Problems and Actions to Perform

Command/Tool	Command Output/Result	Action
netstat -i	Ierrs/Ipks > 25%	The host may be dropping packets, causing high input error rate. To compensate for bandwidth-limited network hardware: reduce the packet size; set the read buffer size, rsize and/or the write buffer size wsize to 2048 when using mount or in the /etc/vfstab file. See "To Check the Network" on page 39 in Chapter 3.
nfsstat -s	readlink > 10%	Replace symbolic links with mount points.
nfsstat -s	writes > 5%	Install a Prestoserve NFS accelerator (SBus card or NVRAM-NVSIMM) for peak performance. See "Prestoserve NFS Accelerator" on page 76 in Chapter 4.
nfsstat -s	There are any badcalls.	The network may be overloaded. Identify an overloaded network using network interface statistics.
nfsstat -s	getattr > 40%	Increase the client attribute cache using the actimeo option. Make sure the DNLC and inode caches are large. Use vmstat -s to determine the percent hit rate (cache hits) for the DNLC and, if needed, increase ncsiz in the /etc/system file. See "Directory Name Lookup Cache (DNLC)" on page 82 in Chapter 4.
vmstat -s	Hit rate (cache hits) < 90%	Increase ncsiz in the /etc/system file.
Ethernet monitor, for example: SunNet Manager™ SharpShooter, NetMetrix	Load > 35%	Add an Ethernet interface and distribute client load.



# Client Bottlenecks

This section (see TABLE 5-2) shows potential client bottlenecks and how to remedy them.

TABLE 5-2 Client Bottlenecks

Symptom(s)	Command/Tool	Cause	Solution
NFS server <i>hostname</i> not responding or slow response to commands when using NFS-mounted directories	<code>nfsstat</code>	User's path variable	List directories on local file systems first, critical directories on remote file systems second, and then the rest of the remote file systems.
NFS server <i>hostname</i> not responding or slow response to commands when using NFS-mounted directories	<code>nfsstat</code>	Running executable from an NFS-mounted file system	Copy the application locally (if used often).
NFS server <i>hostname</i> not responding; <code>badxid &gt;5%</code> of total calls and <code>badxid = timeout</code>	<code>nfsstat -rc</code>	Client times out before server responds	Check for server bottleneck. If the server's response time isn't improved, increase the <code>timeo</code> parameter in the <code>/etc/vfstab</code> file of clients. Try increasing <code>timeo</code> to 25, 50, 100, 200 (tenths of seconds). Wait one day between modifications and check to see if the number of time-outs decreases.
<code>badxid = 0</code>	<code>nfsstat -rc</code>	Slow network	Increase <code>rsize</code> and <code>wsize</code> in the <code>/etc/vfstab</code> file. Check interconnection devices (bridges, routers, gateways).

# Server Bottlenecks

This section (see TABLE 5-3) shows server bottlenecks and how to remedy them.

TABLE 5-3 Server Bottlenecks

Symptom(s)	Command/Tool	Cause	Solution
NFS server <i>hostname</i> not responding	<code>vmstat -s</code> or <code>iostat</code>	Cache hit rate is < 90%	Adjust the suggested parameters for DNLC, then run to see if the symptom is gone. If not, reset the parameters for DNLC. Adjust the parameters for the buffer cache, then the inode cache, following the same procedure as for the DNLC.
NFS server <i>hostname</i> not responding	<code>netstat -m</code> or <code>nfsstat</code>	Server not keeping up with request arrival rate	Check the network. If the problem is not the network, add appropriate Prestoserve NFS accelerator, or upgrade the server.
High I/O wait time or CPU idle time; slow disk access times or NFS server <i>hostname</i> not responding	<code>iostat -x</code>	I/O load not balanced across disks; the <code>svc_t</code> value is greater than 40 ms	Take a large sample (~2 weeks). Balance the load across disks; add disks as necessary. Add a Prestoserve NFS accelerator for synchronous writes. To reduce disk and network traffic, use <code>tmpfs</code> for <code>/tmp</code> for both server and clients. Measure system cache efficiencies. Balance load across disks; add disks as necessary.
Slow response when accessing remote files	<code>netstat -s</code> or <code>snoop</code>	Ethernet interface dropping packets	If retransmissions are indicated, increase buffer size. For information on how to use <code>snoop</code> , see "snoop" in Appendix A.

# Network Bottlenecks

This section (see TABLE 5-4) shows network-related bottlenecks and how to remedy them.

TABLE 5-4 Network-Related Bottlenecks

Symptoms	Command/Tool	Cause	Solution
Poor response time when accessing directories mounted on different subnets or NFS server <i>hostname</i> not responding	<code>netstat -rs</code>	NFS requests being routed	Keep clients on the subnet directly connected to server.
Poor response time when accessing directories mounted on different subnets or NFS server <i>hostname</i> not responding	<code>netstat -s</code> shows incomplete or bad headers, bad data length fields, bad checksums.	Network problems	Check the network hardware.
Poor response time when accessing directories mounted on different subnets or NFS server <i>hostname</i> not responding; sum of input and output packets per second for an interface is over 600 per second	<code>netstat -i</code>	Network overloaded	The network segment is very busy. If this is a recurring problem, consider adding another (1e) network interface.
Network interface collisions are over 120 per second	<code>netstat -i</code>	Network overloaded	Reduce the number of machines on the network or check the network hardware.
Poor response time when accessing directories mounted on different subnets or NFS server <i>hostname</i> not responding	<code>netstat -i</code>	High packet collision rate (Collis/Opkts>.10)	<ul style="list-style-type: none"><li>- If packets are corrupted, it may be due to a corrupted MUX box; use the Network General Sniffer product or another protocol analyzer to find the cause.</li><li>- Check for overloaded network. If there are too many nodes, create another subnet.</li><li>- Check network hardware; could be bad tap, transceiver, hub on 10base-T. Check cable length and termination.</li></ul>



## Using NFS Performance-Monitoring and Benchmarking Tools

---

This appendix discusses tools that help you monitor NFS and network performance. These tools generate information that you can use to tune and improve performance. See Chapter 3, “Analyzing NFS Performance,” and Chapter 4, “Configuring the Server and the Client to Maximize NFS Performance.”

For more information about these tools, refer to their man pages (where applicable). For third-party tools, refer to the product documentation.

This chapter also describes SPEC SFS 2.0, an NFS file server benchmarking tool.

---

# NFS Monitoring Tools

TABLE A-1 describes the tools that you can use to monitor NFS operations and performance.

**TABLE A-1** NFS Operations and Performance-Monitoring Tools

<b>Tool</b>	<b>Function</b>
iostat	Reports I/O statistics, including disk I/O activity
nfsstat	Reports NFS statistics: NFS and RPC (Remote Procedure Call) interfaces to the kernel; can also be used to initialize statistical information
nfswatch	Shows NFS transactions classified by file system; nfswatch is a public domain tool with source code available on the URL: <a href="http://www.ers.ibm.com/~davy/software/nfswatch.html">http://www.ers.ibm.com/~davy/software/nfswatch.html</a>
sar	Reports system activity such as CPU utilization, buffer activity, and disk and tape device activity
SharpShooter*	Pinpoints bottlenecks, balances NFS load across clients and servers; shows effect of distributed applications and balances network traffic across servers; accounts for disk usage by user or group
vmstat	Reports virtual memory statistics including disk activity

---

\* by Network General Corporation, formerly AIM Technology

For additional networking and network monitoring utilities, see the URL:  
<http://www.alw.nih.gov/Security/prog-network.html>

---

# Network Monitoring Tools

Use the tools described in TABLE A-2 to monitor network performance as it relates to NFS.

**TABLE A-2** Network Monitoring Tools

Tool	Function
<code>snoop</code>	Displays information about specified packets on Ethernet
<code>netstat</code>	Displays the contents of network-related data structures
<code>ping</code>	Sends ICMP <code>ECHO_REQUEST</code> packets to network hosts
NetMetrix Load Monitor	Handles network load monitoring and characterization of load in terms of time, source, destination, protocol, and packet size
SunNet Manager	Performs network device monitoring and troubleshooting
LAN analyzers: Network General Sniffer, Novell/Excelan Lanalyzer	Performs packet analysis

## `snoop`

The `snoop` command is part of the Solaris 2.x software environment. The `snoop` command must run by `root` (#) to capture packets in promiscuous mode. To capture packets in non-promiscuous mode, or to analyze packets from a captured file, you do not need to be superuser.

In promiscuous mode, the interface turns off its filter, which enables you to see all packets on the subnet, whether or not they are addressed to your system. You can observe other packets not destined for your system. Promiscuous mode is limited to `root`.

Using the `snoop` command turns a Sun system into a network sniffer, which can detect network problems. It also captures a certain number of network packets, enables you to trace the calls from each client to each server, and displays the contents of the packets. You can also save the contents of the packets to a file, which you can inspect later.

The `snoop` command does the following:

- Logs or displays packets selectively
- Provides accurate time stamps for checking network Remote Procedure Call (RPC) response time
- Formats packets and protocol information in a user-friendly manner

The `snoop` command can display packets in a single-line summary or in expanded form. In summary form, only the data pertaining to the highest level protocol is displayed. For example, an NFS packet will have only NFS information displayed. The underlying RPC, UDP (User Datagram Protocol), IP (Internet Protocol), and network frame information is suppressed, but can be displayed if you choose either of the verbose (`-v` or `-V`) options.

The `snoop` command uses both the packet filter and buffer modules of the Data Link Provider Interface (DLPI) so the packets can be captured efficiently and transmitted to or received from the network.

To view or capture all traffic between any two systems, run `snoop` on a third system.

The `snoop` command is a useful tool if you are considering subnetting, since it is a packet analysis tool. You can use the output of the `snoop` command to drive scripts that accumulate load statistics. The program is capable of breaking the packet header in order to debug it, and to investigate the source of incompatibility problems.

The following shows some examples of how to use `snoop`.

## Looking at Selected Packets in a Capture File (`pkts`)

The statistics show which client is making a read request, and the left column shows the time in seconds, with a resolution of about 4 microseconds.

When a read or write request is made, be sure the server doesn't time-out. If it does, the client has to re-send again, and the client's IP code will break up the write block into smaller UDP blocks. The default write time is .07 seconds. The time-out factor is a tunable parameter in the `mount` command.

**CODE EXAMPLE A-1** Output of the `snoop -i pkts -p99, 108` Command

```
# snoop -i pkts -p99,108
99  0.0027  boutique -> sunroof      NFS C GETATTR FH=8E6C
100 0.0046  sunroof -> boutique      NFS R GETATTR OK
101 0.0080  boutique -> sunroof      NFS C RENAME FH=8E6C
MTra00192 to .nfs08
102 0.0102  marmot -> viper          NFS C LOOKUP FH=561E
screen.r.13.i386
```



**CODE EXAMPLE A-1** Output of the `snoop -i pkts -p99, 108` Command

```
103  0.0072  viper -> marmot          NFS R LOOKUP No such file
or directory
104  0.0085  bugbomb -> sunroof       RLOGIN C PORT=1023 h
105  0.0005  kandinsky -> sparky      RSTAT C Get Statistics
106  0.0004  beeblebrox -> sunroof    NFS C GETATTR FH=0307
107  0.0021  sparky -> kandinsky     RSTAT R
108  0.0073  office -> jeremiah      NFS C READ FH=2584 at
40960 for 8192
```

The following table describes the arguments to the `snoop` command.

**TABLE A-3** Arguments to the `snoop` Command

<code>-i pkts</code>	Displays packets previously captured in the <code>pkts</code> file
<code>-p99,108</code>	Selects packets 99 through 108 to be displayed from a capture file; the first number 99, is the first packet to be captured; the last number, 108, is the last packet to be captured; the first packet in a capture file is packet 1

● **To get more information on a packet, type:**

```
# snoop -i pkts -v 101
```

The command `snoop -i pkts -v 101` obtains more detailed information on packet 101. TABLE A-4 describes the command arguments.

**TABLE A-4** Description of Arguments to the `snoop -i pkts -v 101` Command

<code>-i pkts</code>	Displays packets previously captured in the <code>pkts</code> file
<code>-v</code>	Verbose mode; prints packet headers in detail for packet 101; use this option only when you need information on selected packets

To view NFS packets, type:

```
# snoop -i pkts rpc nfs and sunroof and boutique
1  0.0000  boutique -> sunroof     NFS C GETATTR FH=8E6C
2  0.0046  sunroof -> boutique     NFS R GETATTR OK
3  0.0080  boutique -> sunroof     NFS C RENAME FH=8E6C MTra00192 to .nfs08
```

This example gives a view of the NFS packets between the systems `sunroof` and `boutique`. TABLE A-5 describes the arguments to the previous `snoop` command.

**TABLE A-5** Arguments to the `snoop -i pkts rpc nfs` and `sunroof` and `boutique` Command

<code>-i pkts</code>	Displays packets previously captured in the <code>pkts</code> file
<code>rpc nfs</code>	Displays packets for an RPC call or reply packet for the NFS protocol; the option following <code>nfs</code> is the name of an RPC protocol from <code>/etc/rpc</code> or a program number
<code>and</code>	Performs a logical and operation between two boolean values; for example, <code>sunroof boutique</code> is the same as <code>sunroof and boutique</code>

- To save packets to a new capture file, type:

```
# snoop -i pkts -o pkts.nfs rpc nfs sunroof boutique
```

TABLE A-6 describes the arguments to the previous `snoop` command.

**TABLE A-6** Description of Arguments to the `snoop -i pkts -o.nfs rpc nfs` and `sunroof` and `boutique` Command

<code>-i pkts</code>	Displays packets previously captured in the <code>pkts</code> file
<code>-o pkts.nfs</code>	Saves the displayed packets in the <code>pkts.nfs</code> output file
<code>rpc nfs</code>	Displays packets for an RPC call or reply packet for the NFS protocol; the option following <code>nfs</code> is the name of an RPC protocol from <code>/etc/rpc</code> or a program number

See the `snoop` man page for additional details on options used with the `snoop` command and additional information about using `snoop`.

## SPEC System File Server 2.0

SPEC System File Server (SFS) 2.0 measures NFS file server throughput and response time. It is a one test benchmark suite consisting of 097.LADDIS. It contains an updated workload that was developed based on a survey of more than 1,000 NFS servers in different application environments. The workload is larger and the

response-time threshold is lower than those used in SFS 1.1, due to advances in server technologies. Because of these and other changes, you cannot compare SPEC SFS 2.0 results to SFS 1.1 or SFS 1 results.

In addition to general code improvements, SPEC SFS 2.0 includes these enhancements

- Measures results for both NFS Version 2 and 3
- Adds support for TCP (either TCP or UDP can be used as the network transport)
- Operation mix more closely matches real-world NFS workloads
- Improved interface to accommodate both accomplished and novice users

Two reference points are considered when reporting 097.LADDIS:

- NFS operation throughput—The peak number of NFS operations the target server can complete in a given number of milliseconds. The larger the number of operations an NFS server can support, the more users it can serve.
- Response time—The average time needed for an NFS client to receive a reply from a target server in response to an NFS request. The response time of an NFS server is the client's perception of how fast the server is.

LADDIS is designed so that its workload can be incrementally increased until the target server performance falls below a certain level. That point is defined as an average response time exceeding 50ms. This restriction is applied when deriving the maximum throughput in NFS operations per second for which the response time does not exceed 50 ms.

If throughput continues to increase with the workload, the throughput figure at 50 ms is reported. In many cases, throughput will start to fall off at a response time below the 50 ms limit. In these cases, the tables in this chapter report the response time at the point of maximum throughput.

## 0.97 LADDIS Benchmark

The SPEC SFS 2.0 (0.97 LADDIS) benchmark is a synthetic NFS workload based on an application abstraction, an NFS operation mix, and an NFS operation request rate. The workload generated by the benchmark emulates an intensive software development environment at the NFS protocol level. The LADDIS benchmark makes direct RPC calls to the server, eliminating any variation in NFS client implementation. This makes it easier to control the operation mix and workload, especially for comparing results between vendors. However, this also hides the benefits of special client implementations, such as the cache file system client.

TABLE A-7 shows the NFS operations mix. These percentages indicate the relative number of calls made to each operation.

**TABLE A-7** NFS Operations Mix by Call

<b>NFS Operation</b>	<b>Percent Mix</b>
Lookup	34
Read	22
Write	15
GetAttr	13
ReadLink	8
ReadDir	3
Create	2
Remove	1
Statfs	1
SetAttr	1

The LADDIS benchmark for NFS file systems uses an operation mix that is 15 percent write operations. If your NFS clients generate only one to two percent write operations, LADDIS underestimates your performance. The greater the similarity between the operation mixes, the more reliable the maximum throughput in NFS operations is as a reference.

Running the benchmark requires the server being benchmarked to have at least two NFS clients (the NFS load generators), and one or more isolated networks. The ability to support multiple networks is important because a single network may become saturated before the server maximum performance point is reached. One client is designated as the LADDIS Prime Load Generator. The Prime Load Generator controls the execution of the LADDIS load generating code on all load-generating clients. It typically controls the benchmark. In this capacity, it is responsible for collecting throughput and response time data at each of the workload points and for generating results.

To improve response time, configure your NFS server with the NVRAM-NVSIMM Prestoserve NFS accelerator. NVSIMMs provide storage directly in the high-speed memory subsystem. Using NVSIMMs results in considerably lower latency and reduces the number of disks required to attain a given level of performance.

Since there are extra data copies in and out of the NVSIMM, the ultimate peak throughput is reduced. Because NFS loads rarely sustain peak throughput, the better response time using the NVSIMMs is preferable. For information on the Prestoserve NFS accelerator, see “Prestoserve NFS Accelerator” on page 76 in Chapter 4.

## SPEC SFS 2.0 Results

Sun Microsystems has run SPEC SFS 2.0 benchmarks on the Sun Enterprise 3000-6000 family of servers. The benchmarks were run with NFS Version 2 and NFS Version 3. TABLE A-8 shows the results with Version 2. TABLE A-9 shows the results with Version 3.

**TABLE A-8** SPEC SFS 2.0 Results With Version 2

System	Number of CPUs	Result	Overall Response Time
Sun Enterprise 3000	6	11806	5.1
Sun Enterprise 4000	12	20406	6.7
Sun Enterprise 6000	18	25639	9.9

**TABLE A-9** SPEC SFS 2.0 Results With Version 3

System	Number of CPUs	Result	Overall Response Time
Sun Enterprise 3000	6	5903	5.4
Sun Enterprise 4000	12	10592	5.6



# Index

---

## NUMERICS

- 100 Mbit Ethernet, 84
- 64-bit file size
  - NFS version 3, 4

## A

- asynchronous writes
  - NFS version 3, 5
- ATM, 63

## B

- badxid, 89
- bottlenecks
  - network-related, 91
  - pinpointing, 94
- bridges and routers dropping packets, 40
- buffer cache
  - adjusting, `bufhwm`, 80
  - increasing, 52
- buffer sizes, identifying, 79
- `bufhwm`, 80

## C

- cache file system, adding, 67
- cache hit rate, 55, 82, 90
- cache size, adjusting, `maxusers`, 80

- checking
  - client, 56
  - network, 38
  - NFS server, 42
- client
  - bottlenecks, 89
  - checking, 56
  - NFS problems, 56
- configuration recommendations for NFS
  - performance, 61
- configuring
  - CPU, 72
  - disk drives, 65
    - `/etc/init.d/nfs.server`, 78
    - `/etc/system`, 78
  - memory, 73
- CPU
  - configuring, 72
  - in NFS servers guidelines, 73
- CPU idle time, 90
- CPU utilization, determining, 72
- `cron`, 67
- `crontab`, 52

## D

- data structures, network-related, displaying
  - contents, 95
- data, collecting, long-term, 52
- dedicated NFS server
  - Netra NFS 150 Server, 13

`/dev/dsk` entries  
determining for exported file systems, 45

`df -k`, 43

Directory Name Lookup Cache (DNLC), 82

disk

- access load, spreading, 70
- activity, reporting, 94
- array, technology used, 32
- array, using, 28
- concatenation, 70
- configuration, 71
- constraints, easing of, 65
- load, spreading out, 52
- mirroring, 70
- statistics for each disk, 47
- striping, 70
- utilization, 65

disk drive

- configuration rules, 69
- configuring, 65
- data layout, 71
- load balancing, 90

disk names into disk numbers

- translating, 48

disk units

- SPARCstorage MultiPack, 34
- SPARCstorage UniPack, 35

DNLC, 82

- cache hits, 55
- hit rate, 55
- setting, 90

drive

- data layout, 71
- load balancing, 90
- number supported, 31

drive channel, 31

dropping packets

- bridges and routers, 39

## E

echo packets

- round trip time, 40

`/etc/init.d/nfs.server`  
tuning, 78

`/etc/system`, 78, 79

kernel variables

- modifying using `/etc/system`, 79

tuning

- `/etc/system`, 78

Ethernet, 64

- packets, displaying information, 95

Excelan Lanalyzer, 95

exporting file systems

- determining, 42

## F

FastEthernet, 84

FDDI, 63, 84

file system

- heavy usage, 66
- paging from disk, 74

file systems, mounted

- determining, 43
- displaying statistics, 57

## H

hit rate, 55, 82

host, number supported, 31

hot swap, 32

## I

I/O load

- not balanced across disks, 90

I/O wait time, high, 90

inode cache, increasing, 83

interlace size, 70

`iostat`, 47, 48, 90, 94

`iostat -x`, 90

## J

JumpStart, 67



## L

LADDIS, 98  
LAN analyzers, 95  
load balancing, 71  
`ls -lL`  
    identifying `/dev/dsk` entries, 46

## M

`maxusers`  
    parameters derived from, 80  
memory bound, determining, 74  
memory configuration, 73, 75  
memory requirements  
    calculating, 75  
metadisk, 43  
metastat, 43  
mpstat, 72

## N

`ncsize`, setting, 55  
NetMatrix, 95  
Netra NFS150 Server system, 13  
`netstat`, 95  
`netstat -i`, 39, 87, 91  
`netstat -m`, 90  
`netstat -rs`, 91  
`netstat -s`, 90  
network  
    checking, 38  
    collisions, checking with `netstat`, 40  
    configuring, 63  
    device monitoring and troubleshooting, 95  
    monitoring tools, 95  
    overloaded, 91  
    problems, 91  
    requirements  
        attribute-intensive applications, 64  
        data-intensive applications, 63  
        systems with more than one class of users, 64  
    subnetting, 96  
    tracing calls, 95  
    tuning, 63

Network General Sniffer, 95

## NFS

    characteristics, 1  
    load balancing, 94  
    monitoring tools, 94  
    network and performance tools, 93  
    operation throughput, 99  
    performance, increasing with the SPARCstorage  
        Array, 30  
    problems  
        client, 56  
        displaying server statistics, 52  
    requests, 1  
    server not responding, 89  
    server workload, balancing, 62  
    server, checking, 42  
    statistics, reporting, 94  
    threads in `/etc/init.d/nfs.server`, 78  
    transactions, showing, 94  
NFS server, dedicated  
    Netra NFS 150 Server, 13  
NFS version 3, 2  
    64-bit file size, 4  
    asynchronous writes, 5  
    read directory with attributes, 5  
    weak cache consistency, 5  
`nfsstat`, 90, 94  
`nfsstat -c`, 56  
`nfsstat -m`, 57  
`nfsstat -rc`, 89  
`nfsstat -s`, 52, 88  
`nfswatch`, 94  
number of packets and collisions/errors per  
    network, 39

## O

Online Disk Suite, 52, 70  
    spreading disk access load, 70  
    using log-based file systems with, 71  
optimizing data layout on disk drives, 70

## P

packet analysis, 95

- packet size specifications, 40
- packets
  - calculating packet error rate, 40
  - dropping bridges and routers, 40
  - echo, round trip time, 40
  - Ethernet, displaying information, 95
- parameters, tuning, 78
- performance monitor
  - Ultra Enterprise 3000, 4000, 5000, 6000 systems, 17
- performance tuning recommendations, 88
- performance-monitoring tools, 93
- ping, 95
- ping -s, 40, 41
- poor response time, 91
- presto, 55
- Prestoserve NFS accelerator
  - adding, 76
  - checking its state, 55
- procedures
  - checking each client, 56
  - checking the network, 38
  - tuning, 37, 62
    - general performance improvement, 37
    - performance problem resolution, 38

## R

- RAID, 29
- RAID level, 32
- RAID Manager, 32
- random I/O capacity, 65
- read directory with attributes
  - NFS version 3, 5
- read throughput, increasing, 84
- read-aheads, increasing, NFS clients, 84
- read-only data, 66
- redundant, 32
- replicating
  - data, 66
  - file systems, 66
- response time, 99
  - poor, 91

## S

- sar, 48, 94
- scan rate, 74
- SCSI controller, 31
- SCSI host, 31
- SCSI-2 bus, 31
- server
  - bottlenecks, 90
  - checking, 42
  - statistics, identifying NFS problems, 52
- share, 42
- SharpShooter, 94
- slow disk access times, 90
- slow response, 90
- snoop, 90, 95
- software
  - RAID Manager, 32
- Solstice SyMON, 17
- SPARCcenter 2000
  - expandability, 20
  - main memory, 20
  - modules, 20
  - overview, 19
- SPARCcenter 2000E
  - expandability, 20
  - main memory, 20
  - modules, 20
  - overview, 19
- SPARCserver 1000
  - features, 20
- SPARCserver 1000E
  - features, 20
- SPARCserver 20
  - configurations, 26
  - features, 27
  - overview, 26
- SPARCstorage Array subsystem
  - features, 28
  - using, 28
- SPARCstorage MultiPack
  - disk units, 34
- SPARCstorageUniPack
  - disk units, 35
- SPEC SFS 2.0, 98
- SunNet Manager, 95

- swap space
  - configuration, 75
  - requirements, calculating, 76
- symbolic links, eliminating, 54
- system activity, reporting, 94
- system monitor
  - Ultra Enterprise 3000, 4000, 5000 and 6000 systems, 17

## T

- troubleshooting, 87
- tuning, 91
  - CPUs, 72
  - cycle, 6
  - disk drives, 65
  - memory, 73
  - network, 63
  - NFS performance improvement, 61
  - NFS threads in `/etc/init.d/nfs.server`, 78
  - parameters, 78
  - performance problem resolution, 91
  - procedures, 37, 38, 62
    - general performance improvement, 37
    - performance problem resolution, 38
  - recommendations for NFS performance, 61
  - variables, identifying, 79

## U

- `ufs_ninode`, 84
- Ultra Enterprise 1 system, 25
- Ultra Enterprise 2 system, 25
- Ultra Enterprise 4000 server system, 15
- Ultra Enterprise 5000 server system, 15
- Ultra Enterprise 600 server system, 15
- update schedules, 67

## V

- `vfstab`, 67
- virtual memory statistics, reporting, 94
- `vmstat`, 74, 94

- `vmstat -s`, 55, 82, 90

## W

- weak cache consistency, NFS version 3, 5
- `whatdev` script, 45

## Z

- zone-bit recording, 71

