

# Sun™ StorEdge™ FlexiPack User's Guide

---



THE NETWORK IS THE COMPUTER™

A Sun Microsystems, Inc. Business  
901 San Antonio Road  
Palo Alto, CA 94303-4900 USA  
1 650 960-1300 fax 1 650 969-9131

Part No.: 805-4110-10  
Revision A, February 1998

Copyright 1998 Sun Microsystems, Inc., 901 San Antonio Road • Palo Alto, CA 94303 USA. All rights reserved.

This product or document is protected by copyright and distributed under licenses restricting its use, copying, distribution, and decompilation. No part of this product or document may be reproduced in any form by any means without prior written authorization of Sun and its licensors, if any. Third-party software, including font technology, is copyrighted and licensed from Sun suppliers.

Parts of the product may be derived from Berkeley BSD systems, licensed from the University of California. UNIX is a registered trademark in the U.S. and other countries, exclusively licensed through X/Open Company, Ltd.

Sun, Sun Microsystems, the Sun logo, AnswerBook, SunDocs, and Solaris are trademarks, registered trademarks, or service marks of Sun Microsystems, Inc. in the U.S. and other countries. All SPARC trademarks are used under license and are trademarks or registered trademarks of SPARC International, Inc. in the U.S. and other countries. Products bearing SPARC trademarks are based upon an architecture developed by Sun Microsystems, Inc.

The OPEN LOOK and Sun™ Graphical User Interface was developed by Sun Microsystems, Inc. for its users and licensees. Sun acknowledges the pioneering efforts of Xerox in researching and developing the concept of visual or graphical user interfaces for the computer industry. Sun holds a non-exclusive license from Xerox to the Xerox Graphical User Interface, which license also covers Sun's licensees who implement OPEN LOOK GUIs and otherwise comply with Sun's written license agreements.

**RESTRICTED RIGHTS:** Use, duplication, or disclosure by the U.S. Government is subject to restrictions of FAR 52.227-14(g)(2)(6/87) and FAR 52.227-19(6/87), or DFAR 252.227-7015(b)(6/95) and DFAR 227.7202-3(a).

DOCUMENTATION IS PROVIDED "AS IS" AND ALL EXPRESS OR IMPLIED CONDITIONS, REPRESENTATIONS AND WARRANTIES, INCLUDING ANY IMPLIED WARRANTY OF MERCHANTABILITY, FITNESS FOR A PARTICULAR PURPOSE OR NON-INFRINGEMENT, ARE DISCLAIMED, EXCEPT TO THE EXTENT THAT SUCH DISCLAIMERS ARE HELD TO BE LEGALLY INVALID.

Copyright 1998 Sun Microsystems, Inc., 901 San Antonio Road • Palo Alto, CA 94303 Etats-Unis. Tous droits réservés.

Ce produit ou document est protégé par un copyright et distribué avec des licences qui en restreignent l'utilisation, la copie, la distribution, et la décompilation. Aucune partie de ce produit ou document ne peut être reproduite sous aucune forme, par quelque moyen que ce soit, sans l'autorisation préalable et écrite de Sun et de ses bailleurs de licence, s'il y en a. Le logiciel détenu par des tiers, et qui comprend la technologie relative aux polices de caractères, est protégé par un copyright et licencié par des fournisseurs de Sun.

Des parties de ce produit pourront être dérivées des systèmes Berkeley BSD licenciés par l'Université de Californie. UNIX est une marque déposée aux Etats-Unis et dans d'autres pays et licenciée exclusivement par X/Open Company, Ltd.

Sun, Sun Microsystems, le logo Sun, AnswerBook, SunDocs, et Solaris sont des marques de fabrique ou des marques déposées, ou marques de service, de Sun Microsystems, Inc. aux Etats-Unis et dans d'autres pays. Toutes les marques SPARC sont utilisées sous licence et sont des marques de fabrique ou des marques déposées de SPARC International, Inc. aux Etats-Unis et dans d'autres pays. Les produits portant les marques SPARC sont basés sur une architecture développée par Sun Microsystems, Inc.

L'interface d'utilisation graphique OPEN LOOK et Sun™ a été développée par Sun Microsystems, Inc. pour ses utilisateurs et licenciés. Sun reconnaît les efforts de pionniers de Xerox pour la recherche et le développement du concept des interfaces d'utilisation visuelle ou graphique pour l'industrie de l'informatique. Sun détient une licence non exclusive de Xerox sur l'interface d'utilisation graphique Xerox, cette licence couvrant également les licenciés de Sun qui mettent en place l'interface d'utilisation graphique OPEN LOOK et qui en outre se conforment aux licences écrites de Sun.

CETTE PUBLICATION EST FOURNIE "EN L'ETAT" ET AUCUNE GARANTIE, EXPRESSE OU IMPLICITE, N'EST ACCORDEE, Y COMPRIS DES GARANTIES CONCERNANT LA VALEUR MARCHANDE, L'APTITUDE DE LA PUBLICATION A REpondre A UNE UTILISATION PARTICULIERE, OU LE FAIT QU'ELLE NE SOIT PAS CONTREFAISANTE DE PRODUIT DE TIERS. CE DENI DE GARANTIE NE S'APPLIQUERAIT PAS, DANS LA MESURE OU IL SERAIT TENU JURIDIQUEMENT NUL ET NON AVENU.



Adobe PostScript

## Regulatory Compliance Statements

Your Sun product is marked to indicate its compliance class:

- Federal Communications Commission (FCC) — USA
- Department of Communications (DOC) — Canada
- Voluntary Control Council for Interference (VCCI) — Japan

Please read the appropriate section that corresponds to the marking on your Sun product before attempting to install the product.

### FCC Class A Notice

This device complies with Part 15 of the FCC Rules. Operation is subject to the following two conditions:

1. This device may not cause harmful interference.
2. This device must accept any interference received, including interference that may cause undesired operation.

**Note:** This equipment has been tested and found to comply with the limits for a Class A digital device, pursuant to Part 15 of the FCC Rules. These limits are designed to provide reasonable protection against harmful interference when the equipment is operated in a commercial environment. This equipment generates, uses and can radiate radio frequency energy and, if not installed and used in accordance with the instruction manual, may cause harmful interference to radio communications. Operation of this equipment in a residential area is likely to cause harmful interference in which case the user will be required to correct the interference at his own expense.

**Shielded Cables:** Connections between the workstation and peripherals must be made using shielded cables in order to maintain compliance with FCC radio frequency emission limits. Networking connections can be made using unshielded twisted-pair (UTP) cables.

**Modifications:** Any modifications made to this device that are not approved by Sun Microsystems, Inc. may void the authority granted to the user by the FCC to operate this equipment.

### FCC Class B Notice

This device complies with Part 15 of the FCC Rules. Operation is subject to the following two conditions:

1. This device may not cause harmful interference.
2. This device must accept any interference received, including interference that may cause undesired operation.

**Note:** This equipment has been tested and found to comply with the limits for a Class B digital device, pursuant to Part 15 of the FCC Rules. These limits are designed to provide reasonable protection against harmful interference in a residential installation. This equipment generates, uses and can radiate radio frequency energy and, if not installed and used in accordance with the instructions, may cause harmful interference to radio communications. However, there is no guarantee that interference will not occur in a particular installation. If this equipment does cause harmful interference to radio or television reception, which can be determined by turning the equipment off and on, the user is encouraged to try to correct the interference by one or more of the following measures:

- Reorient or relocate the receiving antenna.
- Increase the separation between the equipment and receiver.
- Connect the equipment into an outlet on a circuit different from that to which the receiver is connected.
- Consult the dealer or an experienced radio/television technician for help.

**Shielded Cables:** Connections between the workstation and peripherals must be made using shielded cables in order to maintain compliance with FCC radio frequency emission limits. Networking connections can be made using unshielded twisted pair (UTP) cables.

**Modifications:** Any modifications made to this device that are not approved by Sun Microsystems, Inc. may void the authority granted to the user by the FCC to operate this equipment.

## DOC Class A Notice - Avis DOC, Classe A

This Class A digital apparatus meets all requirements of the Canadian Interference-Causing Equipment Regulations.

Cet appareil numérique de la classe A respecte toutes les exigences du Règlement sur le matériel brouilleur du Canada.

## DOC Class B Notice - Avis DOC, Classe B

This Class B digital apparatus meets all requirements of the Canadian Interference-Causing Equipment Regulations.

Cet appareil numérique de la classe B respecte toutes les exigences du Règlement sur le matériel brouilleur du Canada.

## VCCI 基準について

### 第一種VCCI基準について

第一種VCCIの表示があるワークステーションおよびオプション製品は、第一種情報装置です。これらの製品には、下記の項目が該当します。

この装置は、第一種情報装置(商工業地域において使用されるべき情報装置)で商工業地域での電波障害防止を目的とした情報処理装置等電波障害自主規制協議会(VCCI)基準に適合しております。したがって、本製品を、住宅地域または住宅地域に隣接した地域でご使用になりますと、ラジオ、テレビジョン受信機等に受信障害を与えることがあります。

取り扱い説明書に従って正しくお取り扱いください。

### 第二種VCCI基準について

第二種VCCIの表示  があるワークステーションおよびオプション製品は、第二種情報装置です。これらの製品には、下記の項目が該当します。

この装置は、第二種情報装置(住宅地域または住宅地域に隣接した地域において使用されるべき情報装置)で住宅地域での電波障害防止を目的とした情報処理装置等電波障害自主規制協議会(VCCI)基準に適合しております。しかし、本製品を、ラジオ、テレビジョン受信機に近接してご使用になりますと、受信障害の原因となることがあります。

取り扱い説明書に従って正しくお取り扱いください。

# Declaration of Conformity

Compliance ID: 1622  
Product Name: Sun StorEdge FlexiPack

This product has been tested and complies with:

## EMC

USA - FCC Class B

This equipment complies with Part 15 of the FCC Rules. Operation is subject to the following two conditions:

- 1) This equipment may not cause harmful interference.
- 2) This equipment must accept any interference that may cause undesired operation.

European Union

This equipment complies with the following requirements of the EMC Directive 89/336/EEC:

EN55022 / CISPR22 (1985)	Class B
EN50082-1 IEC801-2 (1991)	4 kV (Direct), 8 kV (Air)
IEC801-3 (1984)	3 V/m
IEC801-4 (1988)	1.0 kV Power Lines, 0.5 kV Signal Lines
EN61000-3-2/IEC1000-3-2(1994)	Pass (Class D)

Safety

This equipment complies with the following requirements of Low Voltage Directive 73/23/EEC:

EC Type Examination Certificates:

EN60950/IEC950

EN60950 w/ Nordic Deviations

Supplementary Information:

This product was tested and complies with all the requirements for the CE Mark.

/ S /

Dennis P. Symanski DATE  
Manager, Product Compliance

/ S /

Stephen McGoldrick DATE  
Quality Assurance Manager

Sun Microsystems, Inc.  
901 San Antonio Road, M/S UMPK15-102  
Palo Alto, CA 94303, USA  
Tel: 650-786-3255  
Fax: 650-786-3723

Sun Microsystems Scotland, Limited  
Springfield, Linlithgow  
West Lothian, EH49 7LR  
Scotland, United Kingdom  
Tel: 0506 670000



## Safety Agency Compliance Statements

Read this section before beginning any procedure. The following text provides safety precautions to follow when installing a Sun Microsystems product.

### Safety Precautions

For your protection, observe the following safety precautions when setting up your equipment:

- Follow all cautions and instructions marked on the equipment.
- Ensure that the voltage and frequency of your power source match the voltage and frequency inscribed on the equipment's electrical rating label.
- Never push objects of any kind through openings in the equipment. Dangerous voltages may be present. Conductive foreign objects could produce a short circuit that could cause fire, electric shock, or damage to your equipment.

### Symbols

The following symbols may appear in this book:



**Caution** – There is risk of personal injury and equipment damage. Follow the instructions.



**Caution** – Hot surface. Avoid contact. Surfaces are hot and may cause personal injury if touched.



**Caution** – Hazardous voltages are present. To reduce the risk of electric shock and danger to personal health, follow the instructions.



**On** – Applies AC power to the system.

Depending on the type of power switch your device has, one of the following symbols may be used:



**Off** – Removes AC power from the system.



**Standby** – The On/Standby switch is in the *standby* position.

### Modifications to Equipment

Do not make mechanical or electrical modifications to the equipment. Sun Microsystems is not responsible for regulatory compliance of a modified Sun product.

### Placement of a Sun Product



**Caution** – Do not block or cover the openings of your Sun product. Never place a Sun product near a radiator or heat register. Failure to follow these guidelines can cause overheating and affect the reliability of your Sun product.

### SELV Compliance

Safety status of I/O connections comply to SELV requirements.

### Power Cord Connection



**Caution** – Sun products are designed to work with single-phase power systems having a grounded neutral conductor. To reduce the risk of electric shock, do not plug Sun products into any other type of power system. Contact your facilities manager or a qualified electrician if you are not sure what type of power is supplied to your building.



**Caution** – Not all power cords have the same current ratings. Household extension cords do not have overload protection and are not meant for use with computer systems. Do not use household extension cords with your Sun product.



**Caution** – Your Sun product is shipped with a grounding type (three-wire) power cord. To reduce the risk of electric shock, always plug the cord into a grounded power outlet.

The following caution applies only to devices with a **Standby** power switch:



**Caution** – The power switch of this product functions as a standby type device only. The power cord serves as the primary disconnect device for the system. Be sure to plug the power cord into a grounded power outlet that is nearby the system and is readily accessible. Do not connect the power cord when the power supply has been removed from the system chassis.

## Lithium Battery



**Caution** – On Sun CPU boards, there is a lithium battery molded into the real-time clock, SGS No. MK48T59Y, MK48TXXB-XX, MK48T18-XXXPCZ, M48T59W-XXXPCZ, or MK48T08. Batteries are not customer replaceable parts. They may explode if mishandled. Do not dispose of the battery in fire. Do not disassemble it or attempt to recharge it.

## System Unit Cover

You must remove the cover of your Sun computer system unit in order to add cards, memory, or internal storage devices. Be sure to replace the top cover before powering up your computer system.



**Caution** – Do not operate Sun products without the top cover in place. Failure to take this precaution may result in personal injury and system damage.

## Laser Compliance Notice

Sun products that use laser technology comply with Class 1 laser requirements.

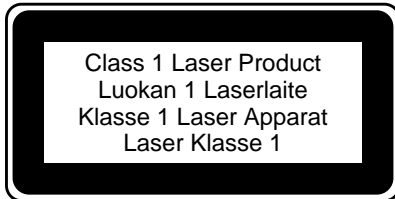

## CD-ROM



**Caution** – Use of controls, adjustments, or the performance of procedures other than those specified herein may result in hazardous radiation exposure.

## Einhaltung sicherheitsbehördlicher Vorschriften

Auf dieser Seite werden Sicherheitsrichtlinien beschrieben, die bei der Installation von Sun-Produkten zu beachten sind.

### Sicherheitsvorkehrungen

Treffen Sie zu Ihrem eigenen Schutz die folgenden Sicherheitsvorkehrungen, wenn Sie Ihr Gerät installieren:

- Beachten Sie alle auf den Geräten angebrachten Warnhinweise und Anweisungen.

- Vergewissern Sie sich, daß Spannung und Frequenz Ihrer Stromquelle mit der Spannung und Frequenz übereinstimmen, die auf dem Etikett mit den elektrischen Nennwerten des Geräts angegeben sind.
- Stecken Sie auf keinen Fall irgendwelche Gegenstände in Öffnungen in den Geräten. Leitfähige Gegenstände könnten aufgrund der möglicherweise vorliegenden gefährlichen Spannungen einen Kurzschluß verursachen, der einen Brand, Stromschlag oder Geräteschaden herbeiführen kann.

## Symbole

Die Symbole in diesem Handbuch haben folgende Bedeutung:



**Achtung** – Gefahr von Verletzung und Geräteschaden. Befolgen Sie die Anweisungen.



**Achtung** – Hohe Temperatur. Nicht berühren, da Verletzungsgefahr durch heiße Oberfläche besteht.



**Achtung** – Gefährliche Spannungen. Anweisungen befolgen, um Stromschläge und Verletzungen zu vermeiden.



**Ein** – Setzt das System unter Wechselstrom.

Je nach Netzschaltertyp an Ihrem Gerät kann eines der folgenden Symbole benutzt werden:



**Aus** – Unterbricht die Wechselstromzufuhr zum Gerät.



**Wartezustand** (Stand-by-Position) - Der Ein-/Wartezustand-Schalter steht auf Wartezustand. Änderungen an Sun-Geräten.

Nehmen Sie keine mechanischen oder elektrischen Änderungen an den Geräten vor. Sun Microsystems, übernimmt bei einem Sun-Produkt, das geändert wurde, keine Verantwortung für die Einhaltung behördlicher Vorschriften



## Aufstellung von Sun-Geräten



**Achtung** – Um den zuverlässigen Betrieb Ihres Sun-Geräts zu gewährleisten und es vor Überhitzung zu schützen, dürfen die Öffnungen im Gerät nicht blockiert oder verdeckt werden. Sun-Produkte sollten niemals in der Nähe von Heizkörpern oder Heizluftklappen aufgestellt werden.

## Einhaltung der SELV-Richtlinien

Die Sicherung der I/O-Verbindungen entspricht den Anforderungen der SELV-Spezifikation.

## Anschluß des Netzkabels



**Achtung** – Sun-Produkte sind für den Betrieb an Einphasen-Stromnetzen mit geerdetem Nulleiter vorgesehen. Um die Stromschlaggefahr zu reduzieren, schließen Sie Sun-Produkte nicht an andere Stromquellen an. Ihr Betriebsleiter oder ein qualifizierter Elektriker kann Ihnen die Daten zur Stromversorgung in Ihrem Gebäude geben.



**Achtung** – Nicht alle Netzkabel haben die gleichen Nennwerte. Herkömmliche, im Haushalt verwendete Verlängerungskabel besitzen keinen Überlastungsschutz und sind daher für Computersysteme nicht geeignet.



**Achtung** – Ihr Sun-Gerät wird mit einem dreidradigen Netzkabel für geerdete Netzsteckdosen geliefert. Um die Gefahr eines Stromschlags zu reduzieren, schließen Sie das Kabel nur an eine fachgerecht verlegte, geerdete Steckdose an.

Die folgende Warnung gilt nur für Geräte mit Wartezustand-Netzschalter:



**Achtung** – Der Ein/Aus-Schalter dieses Geräts schaltet nur auf Wartezustand (Stand-By-Modus). Um die Stromzufuhr zum Gerät vollständig zu unterbrechen, müssen Sie das Netzkabel von der Steckdose abziehen. Schließen Sie den Stecker des Netzkabels an eine in der Nähe befindliche, frei zugängliche, geerdete Netzsteckdose an. Schließen Sie das Netzkabel nicht an, wenn das Netzteil aus der Systemeinheit entfernt wurde.

## Lithiumbatterie



**Achtung** – CPU-Karten von Sun verfügen über eine Echtzeituhr mit integrierter Lithiumbatterie (Teile-Nr. MK48T59Y, MK48TXXB-XX, MK48T18-XXXPCZ, M48T59W-XXXPCZ, oder MK48T08). Diese Batterie darf nur von einem qualifizierten Servicetechniker ausgewechselt werden, da sie bei falscher Handhabung explodieren kann. Werfen Sie die Batterie nicht ins Feuer. Versuchen Sie auf keinen Fall, die Batterie auszubauen oder wiederaufzuladen.

## Gehäuseabdeckung

Sie müssen die obere Abdeckung Ihres Sun-Systems entfernen, um interne Komponenten wie Karten, Speicherchips oder Massenspeicher hinzuzufügen. Bringen Sie die obere Gehäuseabdeckung wieder an, bevor Sie Ihr System einschalten.



**Achtung** – Bei Betrieb des Systems ohne obere Abdeckung besteht die Gefahr von Stromschlag und Systemschäden.

## Einhaltung der Richtlinien für Laser

Sun-Produkte, die mit Laser-Technologie arbeiten, entsprechen den Anforderungen der Laser Klasse 1.

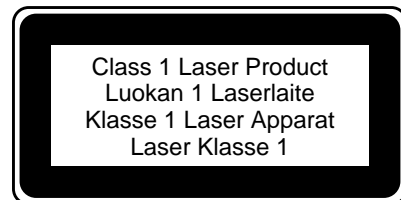

## CD-ROM



**Warnung** – Die Verwendung von anderen Steuerungen und Einstellungen oder die Durchführung von Prozeduren, die von den hier beschriebenen abweichen, können gefährliche Strahlungen zur Folge haben.

## Conformité aux normes de sécurité

Ce texte traite des mesures de sécurité qu'il convient de prendre pour l'installation d'un produit Sun Microsystems.

## Mesures de sécurité

Pour votre protection, veuillez prendre les précautions suivantes pendant l'installation du matériel :

- Suivre tous les avertissements et toutes les instructions inscrites sur le matériel.
- Vérifier que la tension et la fréquence de la source d'alimentation électrique correspondent à la tension et à la fréquence indiquées sur l'étiquette de classification de l'appareil.
- Ne jamais introduire d'objets quels qu'ils soient dans une des ouvertures de l'appareil. Vous pourriez vous trouver en présence de hautes tensions dangereuses. Tout objet conducteur introduit de la sorte pourrait produire un court-circuit qui entraînerait des flammes, des risques d'électrocution ou des dégâts matériels.

## Symboles

Vous trouverez ci-dessous la signification des différents symboles utilisés :



**Attention** : risques de blessures corporelles et de dégâts matériels. Veuillez suivre les instructions.



**Attention** : surface à température élevée. Evitez le contact. La température des surfaces est élevée et leur contact peut provoquer des blessures corporelles.



**Attention** : présence de tensions dangereuses. Pour éviter les risques d'électrocution et de danger pour la santé physique, veuillez suivre les instructions.



**MARCHE** – Votre système est sous tension (courant alternatif).

Un des symboles suivants sera peut-être utilisé en fonction du type d'interrupteur de votre système:



**ARRÊT** – Votre système est hors tension (courant alternatif).



**VEILLEUSE** – L'interrupteur Marche/Veilleuse est en position « Veilleuse ».

## Modification du matériel

Ne pas apporter de modification mécanique ou électrique au matériel. Sun Microsystems n'est pas responsable de la conformité réglementaire d'un produit Sun qui a été modifié.

## Positionnement d'un produit Sun



**Attention** : pour assurer le bon fonctionnement de votre produit Sun et pour l'empêcher de surchauffer, il convient de ne pas obstruer ni recouvrir les ouvertures prévues dans l'appareil. Un produit Sun ne doit jamais être placé à proximité d'un radiateur ou d'une source de chaleur.

## Conformité SELV

Sécurité : les raccordements E/S sont conformes aux normes SELV.

## Connexion du cordon d'alimentation



**Attention** : les produits Sun sont conçus pour fonctionner avec des alimentations monophasées munies d'un conducteur neutre mis à la terre. Pour écarter les risques d'électrocution, ne pas brancher de produit Sun dans un autre type d'alimentation secteur. En cas de doute quant au type d'alimentation électrique du local, veuillez vous adresser au directeur de l'exploitation ou à un électricien qualifié.



**Attention** : tous les cordons d'alimentation n'ont pas forcément la même puissance nominale en matière de courant. Les rallonges d'usage domestique n'offrent pas de protection contre les surcharges et ne sont pas prévues pour les systèmes d'ordinateurs. Ne pas utiliser de rallonge d'usage domestique avec votre produit Sun.



**Attention** : votre produit Sun a été livré équipé d'un cordon d'alimentation à trois fils (avec prise de terre). Pour écarter tout risque d'électrocution, branchez toujours ce cordon dans une prise mise à la terre.

L'avertissement suivant s'applique uniquement aux systèmes équipés d'un interrupteur VEILLEUSE:



**Attention** : le commutateur d'alimentation de ce produit fonctionne comme un dispositif de mise en veille uniquement. C'est la prise d'alimentation qui sert à mettre le produit hors tension. Veuillez donc à installer le produit à proximité d'une prise murale facilement accessible. Ne connectez pas la prise d'alimentation lorsque le châssis du système n'est plus alimenté.

## Batterie au lithium



**Attention** : sur les cartes CPU Sun, une batterie au lithium (référence MK48T59Y, MK48TXXB-XX, MK48T18-XXXPCZ, M48T59W-XXXPCZ, ou MK48T08.) a été moulée dans l'horloge temps réel SGS. Les batteries ne sont pas des pièces remplaçables par le client. Elles risquent d'exploser en cas de mauvais traitement. Ne pas jeter la batterie au feu. Ne pas la démonter ni tenter de la recharger.

## Couvercle

Pour ajouter des cartes, de la mémoire, ou des unités de stockage internes, vous devrez démonter le couvercle de l'unité système Sun. Ne pas oublier de remettre ce couvercle en place avant de mettre le système sous tension.



**Attention** : il est dangereux de faire fonctionner un produit Sun sans le couvercle en place. Si l'on néglige cette précaution, on encourt des risques de blessures corporelles et de dégâts matériels.

## Conformité aux certifications Laser

Les produits Sun qui font appel aux technologies lasers sont conformes aux normes de la classe 1 en la matière.

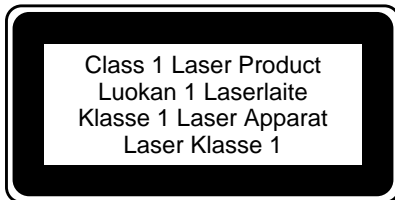

## CD-ROM



**Attention** – L'utilisation de contrôles, de réglages ou de performances de procédures autre que celle spécifiée dans le présent document peut provoquer une exposition à des radiations dangereuses.

## Normativas de seguridad

El siguiente texto incluye las medidas de seguridad que se deben seguir cuando se instale algún producto de Sun Microsystems.

## Precauciones de seguridad

Para su protección observe las siguientes medidas de seguridad cuando manipule su equipo:

- Siga todas las avisos e instrucciones marcados en el equipo.
- Asegúrese de que el voltaje y la frecuencia de la red eléctrica concuerdan con las descritas en las etiquetas de especificaciones eléctricas del equipo.
- No introduzca nunca objetos de ningún tipo a través de los orificios del equipo. Pueden haber voltajes peligrosos. Los objetos extraños conductores de la electricidad pueden producir cortocircuitos que provoquen un incendio, descargas eléctricas o daños en el equipo.

## Símbolos

En este libro aparecen los siguientes símbolos:



**Precaución** – Existe el riesgo de lesiones personales y daños al equipo. Siga las instrucciones.



**Precaución** – Superficie caliente. Evite el contacto. Las superficies están calientes y pueden causar daños personales si se tocan.



**Precaución** – Voltaje peligroso presente. Para reducir el riesgo de descarga y daños para la salud siga las instrucciones.



**Encendido** – Aplica la alimentación de CA al sistema.

Según el tipo de interruptor de encendido que su equipo tenga, es posible que se utilice uno de los siguientes símbolos:



**Apagado** – Elimina la alimentación de CA del sistema.



**En espera** – El interruptor de Encendido/En espera se ha colocado en la posición de *En espera*.

## Modificaciones en el equipo

No realice modificaciones de tipo mecánico o eléctrico en el equipo. Sun Microsystems no se hace responsable del cumplimiento de las normativas de seguridad en los equipos Sun modificados.

## Ubicación de un producto Sun



**Precaución** – Para asegurar la fiabilidad de funcionamiento de su producto Sun y para protegerlo de sobrecalentamientos no deben obstruirse o taparse las rejillas del equipo. Los productos Sun nunca deben situarse cerca de radiadores o de fuentes de calor.

## Cumplimiento de la normativa SELV

El estado de la seguridad de las conexiones de entrada/salida cumple los requisitos de la normativa SELV.

## Conexión del cable de alimentación eléctrica



**Precaución** – Los productos Sun están diseñados para trabajar en una red eléctrica monofásica con toma de tierra. Para reducir el riesgo de descarga eléctrica, no conecte los productos Sun a otro tipo de sistema de alimentación eléctrica. Póngase en contacto con el responsable de mantenimiento o con un electricista cualificado si no está seguro del sistema de alimentación eléctrica del que se dispone en su edificio.



**Precaución** – No todos los cables de alimentación eléctrica tienen la misma capacidad. Los cables de tipo doméstico no están provistos de protecciones contra sobrecargas y por tanto no son apropiados para su uso con computadores. No utilice alargadores de tipo doméstico para conectar sus productos Sun.



**Precaución** – Con el producto Sun se proporciona un cable de alimentación con toma de tierra. Para reducir el riesgo de descargas eléctricas conéctelo siempre a un enchufe con toma de tierra.

La siguiente advertencia se aplica solamente a equipos con un interruptor de encendido que tenga una posición "En espera":



**Precaución** – El interruptor de encendido de este producto funciona exclusivamente como un dispositivo de puesta en espera. El enchufe de la fuente de alimentación está diseñado para ser el elemento primario de desconexión del equipo. El equipo debe instalarse cerca del enchufe de forma que este último pueda ser fácil y rápidamente accesible. No conecte el cable de alimentación cuando se ha retirado la fuente de alimentación del chasis del sistema.

## Batería de litio



**Precaución** – En las placas de CPU Sun hay una batería de litio insertada en el reloj de tiempo real, tipo SGS Núm. MK48T59Y, MK48TXXB-XX, MK48T18-XXXPCZ, M48T59W-XXXPCZ, o MK48T08. Las baterías no son elementos reemplazables por el propio cliente. Pueden explotar si se manipulan de forma errónea. No arroje las baterías al fuego. No las abra o intente recargarlas.

## Tapa de la unidad del sistema

Debe quitar la tapa del sistema cuando sea necesario añadir tarjetas, memoria o dispositivos de almacenamiento internos. Asegúrese de cerrar la tapa superior antes de volver a encender el equipo.



**Precaución** – Es peligroso hacer funcionar los productos Sun sin la tapa superior colocada. El hecho de no tener en cuenta esta precaución puede ocasionar daños personales o perjudicar el funcionamiento del equipo.

## Aviso de cumplimiento con requisitos de láser

Los productos Sun que utilizan la tecnología de láser cumplen con los requisitos de láser de Clase 1.

Class 1 Laser Product  
Luokan 1 Laserlaite  
Klasse 1 Laser Apparat  
Laser Klasse 1

## CD-ROM



---

**Precaución** – El manejo de los controles, los ajustes o la ejecución de procedimientos distintos a los aquí especificados pueden exponer al usuario a radiaciones peligrosas.

---

## GOST-R Certification Mark

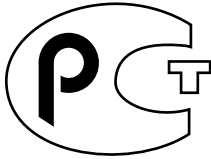

## Nordic Lithium Battery Cautions

### Norge



---

**A D V A R S E L** - Litiumbatteri — Eksplosjonsfare. Ved utskifting benyttes kun batteri som anbefalt av apparatfabrikanten. Brukt batteri returneres apparatleverandøren.

---

### Sverige



---

**WARNING** - Explosionsfara vid felaktigt batteribyte. Använd samma batterityp eller en ekvivalent typ som rekommenderas av apparattillverkaren. Kassera använt batteri enligt fabrikantens instruktion.

---

### Danmark



---

**ADVARSEL!** - Litiumbatteri — Eksplosionsfare ved fejlagtig håndtering. Udsiftning må kun ske med batteri af samme fabrikat og type. Levér det brugte batteri tilbage til leverandøren.

---

### Suomi



---

**VAROITUS** - Paristo voi räjähtää, jos se on virheellisesti asennettu. Vaihda paristo ainoastaan laitevalmistajan suosittelemaan tyyppiin. Hävitä käytetty paristo valmistajan ohjeiden mukaisesti.

---



# Contents

---

- 1. Installation Considerations and Drive Information 1**
  - Sun StorEdge FlexiPack and UltraSCSI 1
  - CD-ROM Drive 2
    - Software Commands 2
    - Cleaning a CD 2
    - Handling and Storing CDs 2
    - ▼ To Insert or Eject a CD 3
    - ▼ To Eject a CD Using Emergency Eject 3
  - Tape Drive 4
    - Software Commands 4
    - Cleaning 4
    - Tape Cartridge 5
  
- 2. Adding and Replacing Drives 7**
  - ▼ To Remove the Cover 7
  - ▼ To Replace the Cover 8
  - ▼ To Add a Half-Height Drive 9
  - ▼ To Remove a Full-Height or Half-Height Drive in the Bottom Position 11
  - ▼ To Install a Drive in the Bottom Position 12

▼ To Replace a SCSI ID Cable 12

**A. Internal and External CableLengths 15**



# Installation Considerations and Drive Information

---

This chapter contains general information about:

- Installing Sun StorEdge FlexiPack units on the same system as ultraSCSI units.
- The Sun StorEdge FlexiPack compact disc read-only memory (CD-ROM) and half-height and full-height tape drives. See the documents that were sent with this documentation for drive-specific information.

---

## Sun StorEdge FlexiPack and UltraSCSI

When you install your Sun StorEdge FlexiPack, be sure you use a host adapter to create a separate SCSI bus for your FlexiPack and any other non-ultraSCSI devices, such as tape or CD-ROM UniPack units.

Do not connect your Sun StorEdge FlexiPack to an embedded host adapter, if that host adapter controls internal system ultraSCSI devices.

Mixing non-ultraSCSI and ultraSCSI devices on the same SCSI bus may cause the ultraSCSI devices to revert to slower speeds.

---

# CD-ROM Drive

## Software Commands

This table contains brief descriptions of some software commands that are commonly used with CD-ROM drives. Refer to the *Solaris Handbook for SMCC Peripherals*, man pages, or AnswerBook on-line documentation for more information.

TABLE 1-1 Software Commands for CD-ROM Drives

Command	Description
mount	Attaches a file system to the file system hierarchy at the mount point, which is the path name of a directory
eject	Ejects media such as a CD-ROM or diskette from the drive

## Cleaning a CD

If your drive cannot read a compact disc (CD), the CD could be dusty or dirty. Clean the CD with a soft, clean, lint-free, *dry* cloth and:

- Clean only the *non-labeled* side of the CD.
- Wipe the CD *radially* from the center to the outside of the CD.



---

**Caution** – Do not use solvents (like benzene, paint thinner, phonograph record cleaner, or antistatic aerosol spray) or abrasive cleaners to clean CDs.

---

## Handling and Storing CDs

- Handle CDs only by their edges; avoid touching CD surfaces.
- Do not write on CDs with permanent marking pens.
- Do not use CDs in high-dust environments.
- Keep CDs out of direct sunlight, extreme sources of heat or cold, and away from dust and moisture.
- Make sure CDs are at room temperature before using them.

- Store CDs in storage boxes so that they remain clean and free of dust.

## ▼ To Insert or Eject a CD

### 1. Push the eject button to open the drive tray.

You may need to unmount the CD before manually ejecting it. See the *Solaris Handbook for SMCC Peripherals* for your system's operating system.

You can also eject the CD by issuing a software command such as `eject`. See the *Solaris Handbook for SMCC Peripherals* for more information.

If your CD does not eject, see "Emergency Ejection," which follows.

### 2. Place the CD, label side up, into the tray.

### 3. Push the eject button to close the tray.

You can also close the tray by lightly pressing on the front of the tray.

## ▼ To Eject a CD Using Emergency Eject

---

**Caution** – Use this procedure only if you have tried to unmount the CD and the eject button does not function. Data may be corrupted if this procedure is performed while the LED indicator is lit.

---

### 1. Turn off power to the CD-ROM drive.

### 2. Use a large straightened wire paper clip (or similar object) and insert it into the emergency eject hole until the tray opens.

The emergency eject hole is about the size of a paper clip and is located on the front of the drive near the eject button.

Refer to the AnswerBook on-line documentation that came with your operating system for more information.

---

# Tape Drive

## Software Commands

This table contains brief descriptions of some software commands that are commonly used with tape drives. Refer to the *Solaris Handbook for SMCC Peripherals*, man pages, or AnswerBook on-line documentation for more information.

TABLE 1-2 Software Commands for Tape Drives

Command	Description
cpio	Copies file archives in and out
mt	Sends commands to a magnetic tape drive
tapetool	Reads files from tape or archives files to tape
st	Acts as a device driver and interface to SCSI tape devices
tar	Creates tape archives and adds or extracts files
ufsdump	Backs up partitions and/or the entire disk
ufsrestore	Moves data from tape back to the disk

## Cleaning

You must clean the tape drive regularly to maintain reliable operation. The frequency of cleaning depends on which tape drive you have. Refer to the cleaning information in your tape drive specifications sheet.

Use only cleaning cartridges that are approved for your tape drive. Approved cleaning cartridges are listed in your tape drive specifications sheet.

Follow the cleaning instructions included with the cleaning cartridge. These cartridges are available from many computer supply companies.



---

**Caution** – Do not use cleaning cartridges or fluids designed for use in video or audio devices. These cartridges or fluids can damage the tape drive.

---

# Tape Cartridge

Use only tape cartridges that are approved for your tape drive. Approved tape cartridges are listed in your tape drive specifications sheet.

These tape cartridges require no pre-formatting and are available from many computer supply companies.

---

**Note** – Do not use video or audio tapes; use only data-grade tape cartridges.

---

## *Thermal Conditioning*

To ensure proper thermal conditioning, keep the cartridge at the same temperature as the drive for 24 hours.

## *Write-Protection*

When the tape is write-protected (read-only mode), data on the tape cannot be overwritten. When the tape is write-enabled, you can write and store new data on the tape.

For information on how to write protect a tape cartridge, refer to your tape drive specifications sheet or documentation that is contained with the tape cartridge.

## *Tensioning Pass*

When you insert a *blank* 1/4-inch tape cartridge or one that has been stored for a long time, run it from one end to the other. This tensioning pass ensures an even distribution of tension throughout the tape. See the *Solaris Handbook for SMCC Peripherals* for specific instructions about tensioning a tape cartridge.

## *Handling and Storage*

- Avoid touching the surface of the tape.
- Make sure the cartridge is at room temperature before using it.
- Keep cartridges away from anything magnetic.
- Keep cartridges out of direct sunlight and sources of heat, cold, or humidity.
- Rewind a cartridge before storing it.
- Store cartridges in a dust-free environment, upright on edge rather than flat.
- Maintain stable temperature for long-term cartridge storage.
- Maintain stable humidity (near 50%) for long-term cartridge storage.



## Adding and Replacing Drives

---

This chapter contains instructions for adding a second half-height CD-ROM or tape drive to your Sun™ StorEdge™ FlexiPack unit and for replacing a full-height tape drive in your Sun StorEdge FlexiPack unit. See the document that was sent with this set for drive-specific information. Refer to *Sun StorEdge FlexiPack Installation* for information about termination.

### ▼ To Remove the Cover

The procedure for removing the covers of the half-height and full-height units is the same.

- 1. Make sure there is no activity to the drive or drives in your enclosure.**
- 2. Turn off the Sun StorEdge FlexiPack unit.**
- 3. Press in the latches at the sides of the cover and slide the cover forward until it stops, about 14 mm (FIGURE 2-1).**
- 4. Lift the cover up and off.**

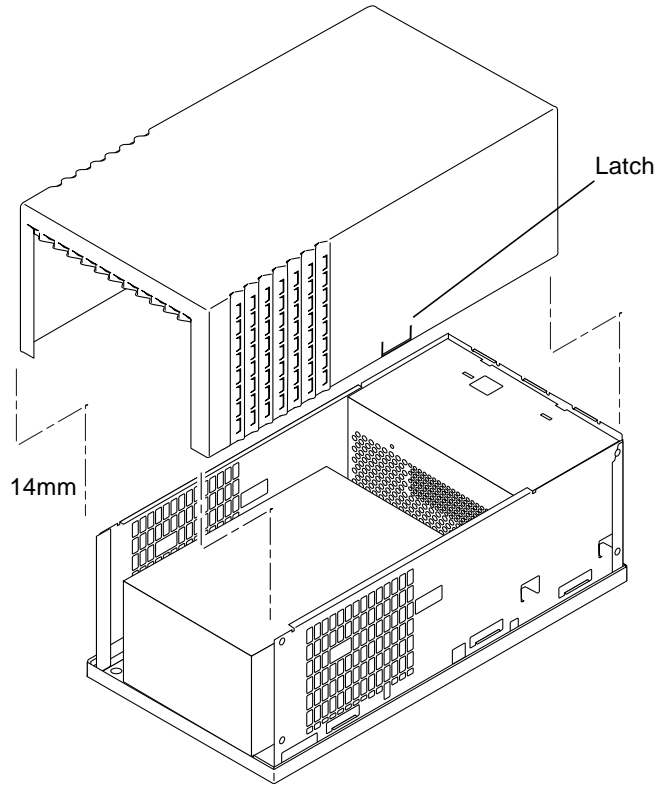

**FIGURE 2-1** Removing or Replacing the Cover of a Full-Height Unit

Inside the cover is a label showing an exploded view of the Sun StorEdge FlexiPack construction and parts for both the half-height and full-height options.

## ▼ To Replace the Cover

The procedure for replacing the covers of the half-height and full-height units is the same.

- 1. Lower the cover over the chassis about 14 mm forward.**
- 2. Push the cover back into the locking position.**



## ▼ To Add a Half-Height Drive

The Sun StorEdge FlexiPack unit is equipped with a bracket for adding an additional half-height device. In addition, the accessory bag contains a 50-68 pin adapter, mounting screws, and a 12-pin SCSI ID cable.

**1. Make sure the Sun StorEdge FlexiPack unit is turned off.**

**2. Remove the cover.**

Refer to “To Remove the Cover” on page 7.

**3. Remove the foam filler, if any.**

**4. Attach a wrist strap to your wrist and to the exposed metal bracket.**

If the half-height device you are adding is a wide SCSI device such as the 20-40 Gbyte, 8-mm Tape Drive, it requires a 12-pin SCSI ID cable from the drive to the I/O board. You must remove the power supply to replace the cable. See “To Replace a SCSI ID Cable” on page 12.

**5. Install the drive.**

**a. Start the four mounting screws in the side of the drive (see FIGURE 2-2).**

Use the lower of the drive’s four screw holes. The mounting screws are in the accessory bag.

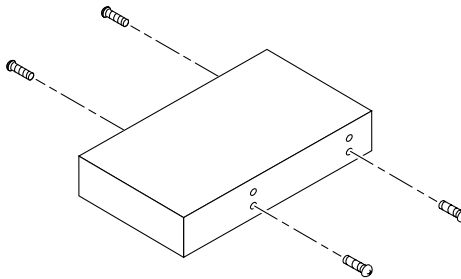

**FIGURE 2-2** Starting the Mounting Screws

**b. Lower the new drive onto the upper bracket tray and slide the drive into position.**

The screws should slide into the bracket slots (see FIGURE 2-3). The bracket and drives are shown outside the enclosure for clarity.

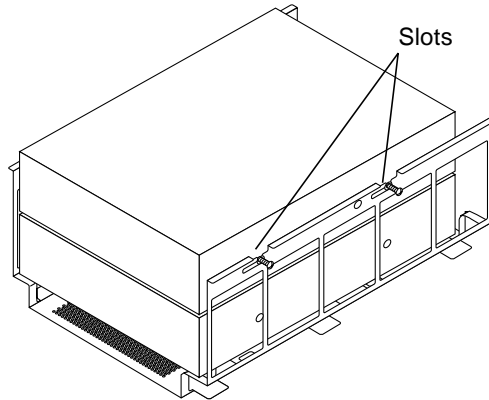

**FIGURE 2-3** Adding a Second Half-Height Drive

**c. Tighten the screws through the holes in the enclosure sides.**

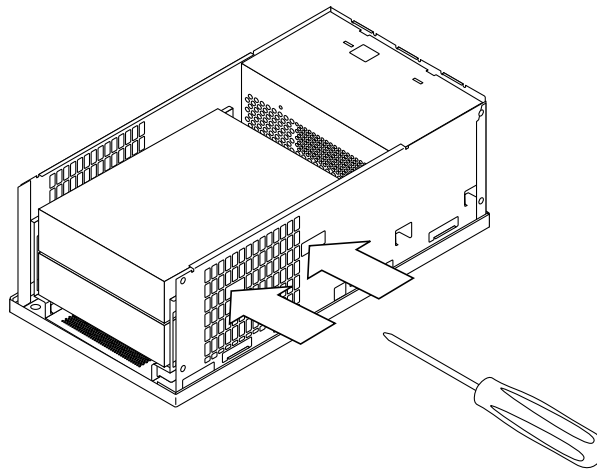

**FIGURE 2-4** Securing the Upper Drive

**6. Connect the SCSI cable.**

**a. If the new drive is a 50-pin device, attach a 50-68 pin adapter to the free end of the SCSI cable.**

The 50-68 pin adapter is contained in the accessory bag.

**7. Attach the SCSI cable to the connector of the new drive.**

**8. Connect the SCSI ID cable.**

**a. Determine the correct SCSI ID cable for your device.**

If the device is a wide SCSI device, such as the 20-40 Gbyte, 8-mm Tape Drive, you must remove the 6-pin ID cable from the I/O board and replace it with a 12-pin ID cable. See “To Replace a SCSI ID Cable” on page 12.

**b. Connect the SCSI ID cable to the drive connector.**

**9. Connect the power cable from the power supply to the top drive.**

**10. Remove the upper filler panel from the cover.**

**11. Replace the cover (see “To Replace the Cover” on page 8).**

The new drive front panel should show.

**12. Set the top SCSI ID switch.**

Refer to the *Solaris Handbook for SMCC Peripherals* for your operating system release for more information.

## ▼ To Remove a Full-Height or Half-Height Drive in the Bottom Position

**1. Remove all CD ROM or tape drive cartridges.**

**2. Make sure the Sun StorEdge FlexiPack unit is turned off.**

**3. Pull out on the tab on the bottom of the unit and pull the drive tray forward.**

It is easier to disconnect the cables with the drive tray in the forward position.

**4. Disconnect the SCSI cable at the back of the drive.**

**5. Disconnect the power cable from the drive.**

**6. Disconnect the SCSI ID cable from the drive.**

The documentation for your drive tells you where the cable connects.

---

**Note** – If the SCSI ID cable must be replaced, you must remove the power supply to connect the replacement ID cable to the I/O board. See “To Replace a SCSI ID Cable” on page 12.

---

**7. Loosen the screws connecting the drive to the drive tray.**

- If the drive is in the upper position in the tray, the screws are at the sides (see FIGURE 2-3).
- If the drive is in the bottom slot, or is a full-height drive, the screws are on the bottom of the drive tray.

8. **Slide the drive out of the bracket and set it on an antistatic mat.**

## ▼ To Install a Drive in the Bottom Position

You can install either a full-height or half-height drive in the bottom position.

1. **Slide the new drive onto the drive tray.**
2. **Secure the drive to the drive tray at the bottom.**

Use the screws from the old drive.
3. **If the new half-height drive is a 50-pin device, make sure a 50-68 pin adapter is in place on the cable.**
4. **Connect the SCSI ribbon cable.**

Refer to the documentation for the drive for where to connect the cable.
5. **Connect the SCSI ID cable to the drive.**

Refer to the documentation for the drive for where to connect the cable.
6. **Connect the power cable.**
7. **Slide the drive tray into the chassis.**

Make sure the drive tray is locked in.
8. **Replace the cover.**
9. **Make sure the SCSI ID switch is set to the desired address.**

Usually the address is the same as the drive you are replacing.

## ▼ To Replace a SCSI ID Cable

1. **Make sure the Sun StorEdge FlexiPack unit is turned off and the power cord is unplugged.**
2. **Attach a wrist strap to your wrist and to the exposed metal of the chassis.**
3. **Remove the power supply (see FIGURE 2-5).**
  - a. **Remove the three screws that secure it to the chassis.**

Remove the lock box at the rear and a screw on each side of the chassis.
  - b. **Lift the power supply and turn it on its side at a 90-degree angle.**

You don't have to remove the cables.

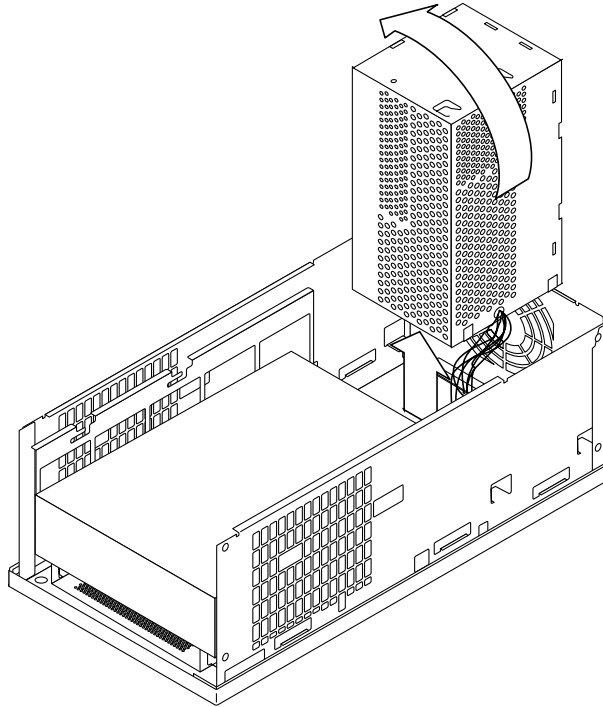

**FIGURE 2-5** Removing the Power Supply

- 4. Remove the SCSI ID cable if you have not already done so.**
- 5. Connect the replacement SCSI ID cable to the board.**
- 6. Replace the power supply.**
  - a. Rotate the power supply in place over the I/O board and lower it onto the support flanges.**
  - b. Install the two screws in the sides and the lock box in the rear.**
- 7. Replace the cover before connecting the power cord (see “To Replace the Cover” on page 8).**



# Internal and External Cable Lengths

---

## External SCSI Cable Length

To connect a Sun StorEdge FlexiPack enclosure to a SCSI host adapter, you can use either a .8 meter cable or a 2 meter cable.

To directly connect a Sun StorEdge FlexiPack enclosure to your desktop system, or to daisy chain it to another SCSI peripheral, use the cable that ships with the unit.



---

**Caution** – Using cables other than those recommended by Sun may result in data loss.

---

TABLE A-1 SCSI External Cable Lengths

Cables	Meters	Inches
68-68 pin cable	0.8	31.4
50-68 pin cable	1.2	47.2
68-68 pin cable or 50-68 pin cable	2.0	78.6

---

# Internal SCSI Cable Length

The Sun StorEdge FlexiPack enclosure does not use internal cables. TABLE A-2 lists the internal cable lengths of supported systems.

**TABLE A-2** Internal Cable Lengths of Supported Systems

Devices and Cables	SCSI Cable Length	
	Meters	Inches
Sun StorEdge UniPack (rem. media)	0.4	15.7
Sun StorEdge UniPack (disk)	0.3	11.8
Sun StorEdge MultiPack	0.9	35.4
Desktop Disk Pack (tape, disk, CD-ROM)	0.3	11.8
Ultra™ 1 Model 140, Model 170	0.9	35.4
Ultra™ 1 Creator and Ultra™ 1 Creator 3D	0.9	35.4
Ultra Enterprise 450	0.9	35.4
Ultra™ 2 Creator and Ultra™ 2 Creator 3D	0.9	35.4
Ultra 30	0.9	35.4
SPARCstation™ 5, 20	1.6	62.6
SPARCstation 4	1.2	48.0
SPARCstation 10, LX, SPARCclassic	0.9	35.4
SPARCstation™ Voyager™	0.4	15.7
SPARCserver™ 1000	1.8	70.2
SBus cards (SBE/S, FSBE/S, SBus SCSI host adapter)	0.1	3.9
Sun Swift PCI Adapter	0.1	3.9
PCI Ultra Single-Ended 2 Channel SCSI Adapter	0.2	7.8
SBus Expansion Subsystem	0.9	35.4