

SPARCclassic/SPARCclassic X/SPARCstation LX Service Manual



THE NETWORK IS THE COMPUTER™

Sun Microsystems Computer Company
A Sun Microsystems, Inc. Business
901 San Antonio Road Palo Alto, CA 94303-4900 USA
650 960-1300
fax 650 969-9131

Part No.: 801-2176-13
Revision A, November 1993

Send comments about this document to: docfeedback@sun.com

1997 Sun Microsystems, Inc., 901 San Antonio Road, Palo Alto, California 94303-4900 U.S.A.

All rights reserved.

This product or document is protected by copyright and distributed under licenses restricting its use, copying, distribution, and decompilation. No part of this product or document may be reproduced in any form by any means without prior written authorization of Sun and its licensors, if any.

Portions of this product may be derived from the UNIX® system, licensed from Novell, Inc., and from the Berkeley 4.3 BSD system, licensed from the University of California. UNIX is a registered trademark in the United States and in other countries and is exclusively licensed by X/Open Company Ltd. Third-party software, including font technology in this product, is protected by copyright and licensed from Sun's suppliers. RESTRICTED RIGHTS: Use, duplication, or disclosure by the U.S. Government is subject to restrictions of FAR 52.227-14(g)(2)(6/87) and FAR 52.227-19(6/87), or DFAR 252.227-7015(b)(6/95) and DFAR 227.7202-3(a).

Sun, Sun Microsystems, the Sun logo, and Solaris are trademarks or registered trademarks of Sun Microsystems, Inc. in the United States and in other countries. All SPARC trademarks are used under license and are trademarks or registered trademarks of SPARC International, Inc. in the United States and in other countries. Products bearing SPARC trademarks are based upon an architecture developed by Sun Microsystems, Inc.

The OPEN LOOK® and Sun™ Graphical User Interfaces were developed by Sun Microsystems, Inc. for its users and licensees. Sun acknowledges the pioneering efforts of Xerox Corporation in researching and developing the concept of visual or graphical user interfaces for the computer industry. Sun holds a nonexclusive license from Xerox to the Xerox Graphical User Interface, which license also covers Sun's licensees who implement OPEN LOOK GUIs and otherwise comply with Sun's written license agreements.

THIS PUBLICATION IS PROVIDED "AS IS" WITHOUT WARRANTY OF ANY KIND, EITHER EXPRESS OR IMPLIED, INCLUDING, BUT NOT LIMITED TO, THE IMPLIED WARRANTIES OF MERCHANTABILITY, FITNESS FOR A PARTICULAR PURPOSE, OR NON-INFRINGEMENT.

Copyright 1997 Sun Microsystems, Inc., 901 San Antonio Road, Palo Alto, Californie 94303-4900 U.S.A. Tous droits réservés.

Ce produit ou document est protégé par un copyright et distribué avec des licences qui en restreignent l'utilisation, la copie et la décompilation. Aucune partie de ce produit ou de sa documentation associée ne peut être reproduite sous aucune forme, par quelque moyen que ce soit, sans l'autorisation préalable et écrite de Sun et de ses bailleurs de licence, s'il y en a.

Des parties de ce produit pourront être dérivées du système UNIX® licencié par Novell, Inc. et du système Berkeley 4.3 BSD licencié par l'Université de Californie. UNIX est une marque enregistrée aux Etats-Unis et dans d'autres pays, et licenciée exclusivement par X/Open Company Ltd. Le logiciel détenu par des tiers, et qui comprend la technologie relative aux polices de caractères, est protégé par un copyright et licencié par des fournisseurs de Sun.

Sun, Sun Microsystems, le logo Sun, et Solaris sont des marques déposées ou enregistrées de Sun Microsystems, Inc. aux Etats-Unis et dans d'autres pays. Toutes les marques SPARC, utilisées sous licence, sont des marques déposées ou enregistrées de SPARC International, Inc. aux Etats-Unis et dans d'autres pays. Les produits portant les marques SPARC sont basés sur une architecture développée par Sun Microsystems, Inc.

Les utilisateurs d'interfaces graphiques OPEN LOOK® et Sun™ ont été développés de Sun Microsystems, Inc. pour ses utilisateurs et licenciés. Sun reconnaît les efforts de pionniers de Xerox Corporation pour la recherche et le développement du concept des interfaces d'utilisation visuelle ou graphique pour l'industrie de l'informatique. Sun détient une licence non exclusive de Xerox sur l'interface d'utilisation graphique, cette licence couvrant aussi les licenciés de Sun qui mettent en place les utilisateurs d'interfaces graphiques OPEN LOOK et qui en outre se conforment aux licences écrites de Sun.

CETTE PUBLICATION EST FOURNIE "EN L'ETAT" SANS GARANTIE D'AUCUNE SORTE, NI EXPRESSE NI IMPLICITE, Y COMPRIS, ET SANS QUE CETTE LISTE NE SOIT LIMITATIVE, DES GARANTIES CONCERNANT LA VALEUR MARCHANDE, L'APTITUDE DES PRODUITS A REpondre A UNE UTILISATION PARTICULIERE OU LE FAIT QU'ILS NE SOIENT PAS CONTREFAISANTS DE PRODUITS DE TIERS.



Adobe PostScript

Contents

Preface xv

1. Product Description 1-1

- 1.1 System Unit 1-1
 - 1.1.1 Main Logic Board 1-4
 - 1.1.2 Memory Modules 1-5
 - 1.1.2.1 Video SIMM 1-5
 - 1.1.2.2 SBus Cards 1-5
 - 1.1.3 Nonvolatile RAM (NVRAM) 1-6
 - 1.1.4 Internal Hard Disk Drive 1-7
 - 1.1.5 Internal Diskette Drive 1-7
 - 1.1.6 Power Supply 1-7
- 1.2 Monitors, Keyboard, and Mouse 1-7
- 1.3 External Storage Devices 1-8
- 1.4 System Interconnections 1-8

2. Troubleshooting Overview 2-1

- 2.1 Default Boot Mode 2-1
- 2.2 Boot PROM Diagnostics 2-1
- 2.3 Low-Level POST Code 2-4
- 2.4 Diagnostic Tools and When to Use Them 2-7

- 2.5 Power-On Self-Test 2-8
- 2.6 Selected On-Board Tests 2-8
- 2.7 Sundiag System Exerciser 2-9
- 2.8 Forth Toolkit 2-9
- 2.9 SunDiagnostic Executive 2-10

- 3. Power-On Self-Test (POST) 3-1**
 - 3.1 Power-On Self-Test (POST) 3-1
 - 3.2 Normal Mode 3-4
 - 3.3 Full Diagnostic Mode 3-4
 - 3.4 Abbreviated Diagnostic Mode 3-4
 - 3.4.1 Setting Up a t*i*p Connection to Another Workstation 3-5
 - 3.5 Tests the POST Runs 3-6
 - 3.6 POST Error Messages 3-8
 - 3.7 Status Lights (LEDs) and Indicators 3-8

- 4. Troubleshooting Procedures 4-1**
 - 4.1 No Video Output on the System Monitor 4-2
 - 4.2 Power-On Does Not Succeed 4-2
 - 4.2.1 Power Supply Test 4-3
 - 4.2.2 System Board Test 4-5
 - 4.2.2.1 Caps Lock Key Fails to Flash On and Off During POST 4-5
 - 4.3 Disk Drive Errors 4-6
 - 4.3.1 Verifying the Built-In SCSI Controller 4-6
 - 4.4 Determining Faulty DSIMM Locations 4-7

- 5. Safety and Tools Requirements 5-1**
 - 5.1 Safety Requirements 5-1
 - 5.2 Symbols 5-2
 - 5.3 System Precautions 5-3

- 5.4 Tools Required 5-3
- 6. Power Off and On 6-1**
 - 6.1 Powering Off the System 6-1
 - 6.1.1 Powering Off When the System Is Working Normally 6-1
 - 6.1.2 Powering Off When the System Does Not Respond Normally 6-3
 - 6.2 Powering On the System 6-4
- 7. Internal Access 7-1**
 - 7.1 Disconnecting the External Cables 7-1
 - 7.2 Opening the System Unit 7-2
 - 7.3 Attaching the Wrist Strap 7-3
 - 7.4 Closing the System Unit 7-4
 - 7.5 Reconnecting the External Cables 7-7
- 8. Major Subassemblies 8-1**
 - 8.1 Power Supply 8-1
 - 8.1.1 Removing the Power Supply 8-1
 - 8.1.2 Replacing the Power Supply 8-3
 - 8.2 Speaker/Power LED Assembly 8-4
 - 8.2.1 Removing the Speaker/Power LED Assembly 8-4
 - 8.2.2 Replacing the Speaker/Power LED Assembly 8-6
 - 8.3 System I/O Board 8-7
 - 8.3.1 Removing the System I/O Board 8-7
 - 8.3.2 Replacing the System I/O Board 8-12
- 9. Storage Devices 9-1**
 - 9.1 Hard Disk Drive 9-1
 - 9.1.1 Removing a Hard Disk Drive 9-2
 - 9.1.2 Preparing a Hard Drive for Installation 9-3
 - 9.1.2.1 Verifying the Jumper Settings 9-4

- 9.1.3 Installing a Hard Disk Drive 9-13
- 9.2 Disk Drive Bracket 9-15
 - 9.2.1 Removing the Disk Drive Mounting Bracket 9-16
 - 9.2.2 Replacing the Disk Drive Mounting Bracket 9-19
- 9.3 Diskette Drive 9-21
 - 9.3.1 Removing the Diskette Drive 9-22
 - 9.3.2 Replacing the Diskette Drive 9-23
- 10. System Board Overview 10-1**
 - 10.1 Before You Begin 10-1
 - 10.2 Damage Prevention 10-2
 - 10.3 Handling System Boards and Assemblies 10-2
 - 10.4 Main Logic Board Layouts 10-4
 - 10.5 Identifying Replaceable System Board Components 10-6
- 11. Main Logic Board and Component Replacement 11-1**
 - 11.1 SBus Cards 11-1
 - 11.1.1 Removing SBus Cards 11-1
 - 11.1.2 Replacing SBus Cards 11-4
 - 11.2 Video SIMM (VSIMM) 11-6
 - 11.2.1 Removing the VSIMM 11-7
 - 11.2.2 Replacing the VSIMM 11-9
 - 11.3 DRAM Single In-line Memory Modules (DSIMMs) 11-10
 - 11.3.1 DSIMM Configurations 11-11
 - 11.3.2 Removing a DSIMM 11-13
 - 11.3.3 Replacing a DSIMM 11-15
 - 11.4 Main Logic Board 11-17
 - 11.4.1 Main Logic Board Voltage Test Points 11-18
 - 11.4.2 Before Replacing the Main Logic Board 11-21
 - 11.4.3 Removing the Main Logic Board 11-24
 - 11.4.4 Installing the New Main Logic Board 11-29

11.5	Nonvolatile RAM (NVRAM)	11-31
11.5.1	Removing the NVRAM	11-31
11.5.2	Replacing the NVRAM	11-33
11.6	SPARCstation LX ISDN Jumper Settings	11-33
12.	Illustrated Parts Breakdown	12-1
12.1	Illustrations of Selected CRUs	12-1
12.2	Replacement Part List	12-4
A.	System Specifications	A-1
A.1	Input Power Requirements	A-1
A.2	Environmental Requirements	A-2
A.3	Physical Specifications	A-3
A.4	Regulatory Compliance	A-3
B.	System Connectors	B-1
B.1	Attachment Unit Interface (AUI) Connector	B-2
B.2	Twisted-Pair Ethernet Connector	B-3
B.3	ISDN Terminal Endpoint Connector	B-3
B.4	ISDN Network Termination Connector	B-4
B.5	Keyboard/Mouse Connector	B-5
B.6	SCSI Connector (External)	B-6
B.7	Serial Connector	B-7
B.8	Parallel Connector	B-8
B.9	13W3 Video Connector	B-9
B.10	Audio Ports and Audio Module	B-9
	B.10.1 Audio Ports	B-9
B.11	Signals for the Audio Ports	B-10
	B.11.1 Audio Line-Out Connector	B-10
	B.11.2 Audio Line-In Connector	B-10
B.12	SCSI Connector (Internal)	B-11

B.13 Diskette Drive Connector (Internal) B-12

B.14 SBus Connector (Internal) B-13

B.15 Power Connector (Internal) B-14

C. On-Board Diagnostics C-1

C.1 Running the On-Board Diagnostics C-1

C.1.1 Test <alias name>, Test <device path> C-3

C.1.2 Test-all C-4

C.1.3 Watch-clock C-4

C.1.4 Watch-net, Watch-aui, Watch-tpe and Watch-net-all C-4

C.1.5 Probe-scsi, Probe-scsi-all C-7

C.1.6 Test-memory C-7

C.2 Returning to the Monitor Prompt C-8

Glossary Glossary-1

Figures

- FIGURE 1-1 Front Panel of the SPARCclassic and SPARCstation LX System Units 1-2
- FIGURE 1-2 Rear Panel of the System Unit 1-3
- FIGURE 1-3 System Unit Internal Components 1-4
- FIGURE 1-4 Typical DSIMM 1-5
- FIGURE 1-5 Typical SBus Card 1-6
- FIGURE 1-6 Connecting the Major System Components 1-9
- FIGURE 2-1 Default Boot Mode 2-3
- FIGURE 3-1 Arrangement of Type-5 Keyboard Diagnostic LEDs 3-2
- FIGURE 3-2 SPARCstation System Banner 3-3
- FIGURE 3-3 System Power LED on Front of System 3-8
- FIGURE 3-4 Arrangement of the Type-5 Keyboard LEDs 3-9
- FIGURE 4-1 Power Supply Connector 4-4
- FIGURE 4-2 DSIMM Slot Locations 4-8
- FIGURE 7-1 Opening the System Unit 7-3
- FIGURE 7-2 Attaching the Wrist Strap 7-4
- FIGURE 7-3 Closing the System Unit 7-6
- FIGURE 7-4 Reconnecting System Components 7-7
- FIGURE 8-1 Removing and Replacing the Power Supply 8-3
- FIGURE 8-2 Removing and Replacing the Speaker/Power LED Assembly 8-6

FIGURE 8-3	System I/O Board and Unit Bottom	8-8
FIGURE 8-4	Extracting the Main Logic Board	8-10
FIGURE 8-5	Raising the Speaker/LED Assembly	8-10
FIGURE 8-6	Removing and Replacing the Main Logic Board	8-11
FIGURE 8-7	Removing the System I/O Board	8-12
FIGURE 8-8	Plugging in the Main Logic Board	8-14
FIGURE 9-1	Hard Disk Drive in the Disk Drive Bracket	9-3
FIGURE 9-2	Jumper Settings for 207-Mbyte Drive With Jumpers on the Left-Hand Side	9-4
FIGURE 9-3	Jumper Settings for 207-Mbyte Drive With Jumpers on the Right-Hand Side	9-5
FIGURE 9-4	Jumper Settings for 424-Mbyte Drive	9-6
FIGURE 9-5	Jumper Settings for Conner 535-Mbyte Drive	9-7
FIGURE 9-6	Jumper Settings for Seagate 535-Mbyte Drive	9-8
FIGURE 9-7	Jumper Settings for 1.0-Gbyte Drive (Part 370-1546)	9-10
FIGURE 9-8	Jumper Settings for Seagate 1.0-Gbyte Drive	9-11
FIGURE 9-9	Jumper Settings for Connor 1.0-Gbyte Drive	9-12
FIGURE 9-10	Installing a Hard Disk Drive	9-14
FIGURE 9-11	Main Logic Board	9-15
FIGURE 9-12	Open View of System Unit	9-17
FIGURE 9-13	Removing the Disk Drive Mounting Bracket	9-18
FIGURE 9-14	Detail of Disk Drive Mounting Bracket	9-19
FIGURE 9-15	Replacing the Disk Drive Mounting Bracket	9-20
FIGURE 9-16	Disk Drive Mounting Bracket	9-22
FIGURE 10-1	Main Logic Board Layout—SPARCclassic/SPARCclassic X Systems	10-4
FIGURE 10-2	Main Logic Board Layout—SPARCstation LX System (Part 270-2233)	10-5
FIGURE 10-3	Main Logic Board Layout—SPARCstation LX System (Part 270-2474)	10-6
FIGURE 10-4	View of Open System Unit	10-8
FIGURE 11-1	Removing the SBus Card	11-3
FIGURE 11-2	SBus Slot Filler Panels	11-3

FIGURE 11-3	Positioning the SBus Card	11-5
FIGURE 11-4	Connecting the SBus Card	11-6
FIGURE 11-5	VSIMM Slot Location	11-8
FIGURE 11-6	Removing the VSIMM	11-9
FIGURE 11-7	Installing the VSIMM	11-10
FIGURE 11-8	Typical DSIMM	11-11
FIGURE 11-9	DSIMM Slot Locations	11-12
FIGURE 11-10	Removing a DSIMM	11-15
FIGURE 11-11	Installing a DSIMM	11-17
FIGURE 11-12	Main Logic Board Layout—SPARCclassic/SPARCclassic X	11-19
FIGURE 11-13	Main Logic Board Layout—SPARCstation LX (Part 270-2233)	11-20
FIGURE 11-14	Main Logic Board Layout—SPARCstation LX (Part 270-2474)	11-21
FIGURE 11-15	Extracting the Main Logic Board	11-27
FIGURE 11-16	Raising the Speaker/LED Assembly	11-27
FIGURE 11-17	Removing and Replacing the Main Logic Board	11-28
FIGURE 11-18	Plugging in the Main Logic Board	11-30
FIGURE 11-19	Locating the NVRAM	11-32
FIGURE 11-20	Removing the NVRAM	11-32
FIGURE 11-21	Default SPARCstation LX ISDN Jumper Settings	11-33
FIGURE 12-1	Exploded View of the Unit Top	12-2
FIGURE 12-2	Exploded View of the Unit Bottom	12-3
FIGURE 12-3	Exploded View of the Disk Drive Mounting Bracket	12-4
FIGURE B-1	Attachment Unit Interface (AUI) Connector	B-2
FIGURE B-2	Twisted-Pair Ethernet Connector	B-3
FIGURE B-3	ISDN Terminal Endpoint Connector	B-3
FIGURE B-4	ISDN Network Termination Connector	B-4
FIGURE B-5	Keyboard/Mouse Connector	B-5
FIGURE B-6	External SCSI Connector	B-6

- FIGURE B-7 Serial Connector B-7
- FIGURE B-8 Parallel Connector B-8
- FIGURE B-9 13W3 Video Connector B-9
- FIGURE B-10 Audio Ports B-10
- FIGURE B-11 Audio Line-out Connector B-10
- FIGURE B-12 Audio Line-in Connector B-10
- FIGURE B-13 Internal SCSI Connector B-11
- FIGURE B-14 Diskette Drive Connector B-12
- FIGURE B-15 SBus Connector B-13
- FIGURE B-16 Power Connector B-14

Tables

TABLE 2-1	NVRAM Parameters Used During POST and Boot Sequence	2-5
TABLE 2-2	Summary of Autoboot and Diagnostic Switch Parameters	2-5
TABLE 2-3	Diagnostic Tools	2-7
TABLE 2-4	On-Board Diagnostics	2-8
TABLE 3-1	Interpreting the Keyboard Diagnostic LEDs	3-2
TABLE 3-2	Listing of POST Tests	3-6
TABLE 4-1	Troubleshooting Tips	4-1
TABLE 4-2	Power Supply Connector Pin Assignments	4-4
TABLE 4-3	Troubleshooting Disk Drive Errors	4-6
TABLE 4-4	Physical Memory Address Ranges for 4-Mbyte and 16-Mbyte SIMMs	4-8
TABLE 4-5	Physical Memory Address Ranges for 1-Mbyte and 2-Mbyte SIMMs	4-9
TABLE 4-6	Determining the Defective DSIMM	4-9
TABLE 5-1	Safety Precautions	5-2
TABLE 9-1	535-Mbyte Conner Drive Configuration Jumpers	9-7
TABLE 9-2	535-Mbyte Seagate Drive Configuration Jumpers	9-9
TABLE 9-3	1.0-Gbyte Seagate Drive Configuration Jumpers	9-11
TABLE 9-4	1.0-Gbyte Conner Drive Configuration Jumpers	9-13
TABLE 10-1	Safety Precautions	10-3
TABLE 10-2	Acronyms for Components of the Main Logic Board	10-7

TABLE 11-1	Memory Configuration Matrix—SPARCclassic X Terminal	11-12
TABLE 11-2	Configuration Matrix for Memory Modules	11-13
TABLE 11-3	SPARCstation LX ISDN Jumper Settings	11-34
TABLE 12-1	Part Number List—Customer Replaceable Units	12-5
TABLE 12-2	Part Number List—Miscellaneous Items	12-7
TABLE 12-3	Part Number List—Related Hardware Documentation	12-7
TABLE A-1	Input Power Requirements and Power Dissipation	A-1
TABLE A-2	Environmental Requirements	A-2
TABLE A-3	Physical Specifications	A-3
TABLE A-4	Regulatory Compliance Information	A-3
TABLE B-1	Pinout for Attachment Unit Interface (AUI) Connector	B-2
TABLE B-2	Pinout for Twisted-Pair Ethernet Connector	B-3
TABLE B-3	Pinout for ISDN Terminal Endpoint Connector	B-3
TABLE B-4	Pinout for ISDN Network Termination Connector	B-4
TABLE B-5	Pinout for Keyboard/Mouse Connector	B-5
TABLE B-6	Pinout for External SCSI Connector	B-6
TABLE B-7	Pinout for Serial Connector	B-7
TABLE B-8	Pinout for Parallel Connector	B-8
TABLE B-9	Pinout for 13W3 Video Connector	B-9
TABLE B-10	Audio Ports	B-10
TABLE B-11	Pinout for Internal SCSI Connector	B-11
TABLE B-12	Pinout for Diskette Drive Connector	B-12
TABLE B-13	Pinout for SBus Connector	B-13
TABLE B-14	Pinout for Power Connector	B-14

Preface

The *SPARCclassic/SPARCclassic X/SPARCstation LX Service Manual* describes how to:

- Identify system problems by running diagnostic programs
- Remove and replace customer replaceable units (CRUs)

This book is written for Sun Field Service representatives, original equipment manufacturers (OEMs), value-added resellers (VARs), and other customers with self-maintenance contracts.

Document Organization

This book is divided into seven parts. A table at the beginning of each part lists the chapters, sections and their page numbers.

- Part 1, “System Information,” describes an overview of the SPARCclassic™/SPARCclassic X/SPARCstation™ product line’s standard features, and its external options.
- Part 2, “Troubleshooting,” provides a troubleshooting overview; explains how to run the Power-On Self-Test (POST) and other system diagnostics; and gives troubleshooting procedures for some frequently encountered problems.
- Part 3, “Preparing for Service,” explains safety requirements, the symbols used in this book, the tools required for replacing customer replaceable units, and how to shut down, power off, and power on the system.
- Part 4, “Subassembly Removal and Replacement,” describes how to open and close the system, attach and remove a wrist strap, and remove and replace subassemblies.
- Part 5, “System Board,” provides an overview of the system board, and describes how to remove and replace the system board, replaceable parts, and components on the system board.

- Part 6, “Illustrated Parts Breakdown,” provides illustrations of the major replaceable parts and lists part numbers.
- Part 7, “Appendixes, Glossary, and Index,” defines physical, electrical, and environmental specifications; lists connector pinouts and signal descriptions; explains how to run selected on-board diagnostics; and provides a glossary of technical terms, and an index.

What Typographic Changes and Symbols Mean

The following table describes the type changes and symbols used in this book.

TABLE P-1 Typographic Conventions

Typeface or Symbol	Meaning	Example
AaBbCc123	The names of commands, files, and directories; on-screen computer output	Edit your <code>.login</code> file. Use <code>ls -a</code> to list all files. system% You have mail.
Return	In text, key names are capitalized	Press the Return key.
Stop-a	Press and hold the Stop key, then type the second character	Press Stop-a
AaBbCc123	What you type, contrasted with on-screen computer output	<div style="border: 1px solid black; padding: 5px; display: inline-block;">system% su Password:</div>
<i>AaBbCc123</i>	Command-line placeholder: replace with a real name or value	To delete a file, type <code>rm filename</code> .
<i>AaBbCc123</i>	Book titles, new words or terms, or emphasized words	Read Chapter 6 in <i>User's Guide</i> . These are called <i>class</i> options. You <i>must</i> be root to do this.
Code samples are included in boxes and may display the following:		
%	UNIX C shell prompt	system%
\$	UNIX Bourne and Korn shell prompt	UNIX Bourne and Korn shell prompt

TABLE P-1 Typographic Conventions (Continued)

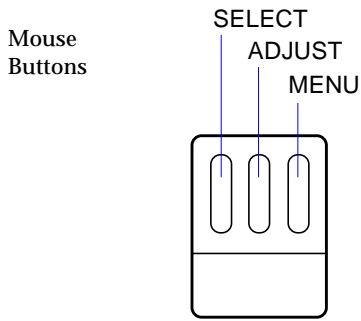
Typeface or Symbol	Meaning	Example
#	Superuser prompt, all shells	Superuser prompt, all shells
	<p>Mouse buttons are referred to in this way:</p>  <p>The diagram shows a rectangular mouse with three vertical buttons. Blue lines connect the labels 'SELECT', 'ADJUST', and 'MENU' to their respective buttons. The label 'Mouse Buttons' is positioned to the left of the mouse.</p>	

Related Books

The following books provide additional information, and are occasionally referenced in this manual:

- *Open Boot Command Summary* provides quick-reference information about the various functions of the Open Boot PROM.
- *Open Boot Command Reference* provides information about advanced functions of the Open Boot PROM.
- *Sundiag User's Guide* covers information about Sundiag, a system exerciser that runs under the SunOS™ operating system. Sundiag displays real-time use of system resources and peripherals.
- *Sundiag User's Guide—Addendum for SMCC Hardware* covers Sundiag topics that are specific to SPARCstation systems.
- *Desktop SPARC Hardware Owner's Guide* provides step-by-step instructions on how to install the system's hardware and software.
- *Using a SPARCclassic X Terminal* contains instructions on how to install the SPARCclassic X hardware.
- *Installing SPARCclassic/SPARCclassic X/SPARCstation LX SIMMs* provides step-by-step information on how to install DSIMMs and VSIMMs in these systems.

- *Desktop Storage Pack Installation & Operation Manual* explains how to install a Desktop Backup Pack, Desktop Disk Pack, or Desktop SunCD™ Pack.
- *Desktop Storage Module Installation & User's Guide* explains how to install and daisy-chain Desktop Storage Modules.
- *SunDiagnostic Executive User's Guide for SPARCstations* explains how to run extensive, configurable tests that are independent of the operating system you use. The SunDiagnostic Executive is the tool of choice when you need thorough diagnostics. With the SunDiagnostic Executive, you can determine which customer replaceable unit needs to be replaced.
- *Sun ISDN-BRI/SBI Hardware Configuration Guide* explains about configuring ISDN jumpers.

Notes, Cautions, and Warnings



Caution – Improper handling by unqualified personnel can cause serious damage to this equipment. Unqualified personnel who tamper with this equipment may be held liable for any resultant damage to the equipment.

Individuals who remove any outer panels to access this equipment must observe all safety precautions and ensure compliance with skill level requirements, certification, and all applicable local and national laws.

Procedures contained in this document must be performed by qualified Field Service-trained maintenance providers.

Note – Before you begin, carefully read each of the procedures in this manual. If you have not performed similar operations on comparable equipment, *do not attempt* to perform these procedures.

Product Description

This chapter presents an overview of the major components of the SPARCclassic, SPARCstation LX systems, and the SPARCclassic X terminal. Acquaint yourself with the overview before servicing and maintaining the hardware for these products.

- Section 1.1 “System Unit”
- Section 1.2 “Monitors, Keyboard, and Mouse”
- Section 1.3 “External Storage Devices”
- Section 1.4 “System Interconnections”

The SPARCclassic or the SPARCstation LX systems also can have an external storage device or other small computer system interface (SCSI), serial, or parallel port devices attached. The SPARCclassic X terminal software does not currently support external devices.

1.1 System Unit

The heart of the SPARCclassic and SPARCstation LX systems is the system unit, which contains the following components:

- Main logic board (MLB)
- Internal hard disk drive
- Internal diskette drive (optional)
- Power supply

FIGURE 1-1 and FIGURE 1-2 show the front and rear panels of the system unit.

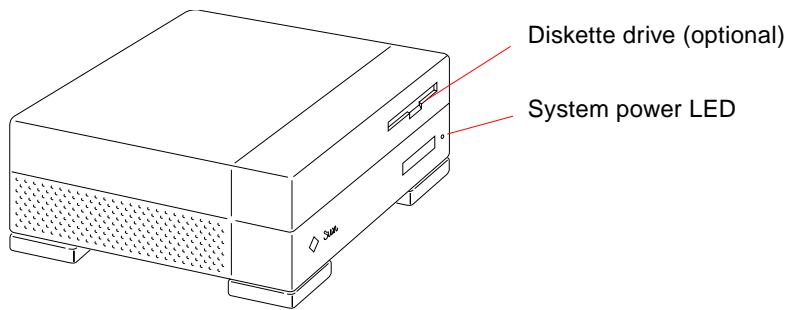

FIGURE 1-1 Front Panel of the SPARCclassic and SPARCstation LX System Units

The SPARCclassic X terminal chassis looks identical to the chassis shown above, except that the components on the list below are either not available or are inactive, and are consequently covered by connector covers:

- Diskette drive slot
- SCSI port
- Audio port
- Parallel port

Internally, the SPARCclassic X terminal differs from the basic SPARCclassic system by the absence of the disk drive and diskette drive. The annotations to FIGURE 1-2 and FIGURE 1-3 indicate the differences among the SPARCclassic system, the SPARCstation LX system, and the SPARCclassic X terminal.

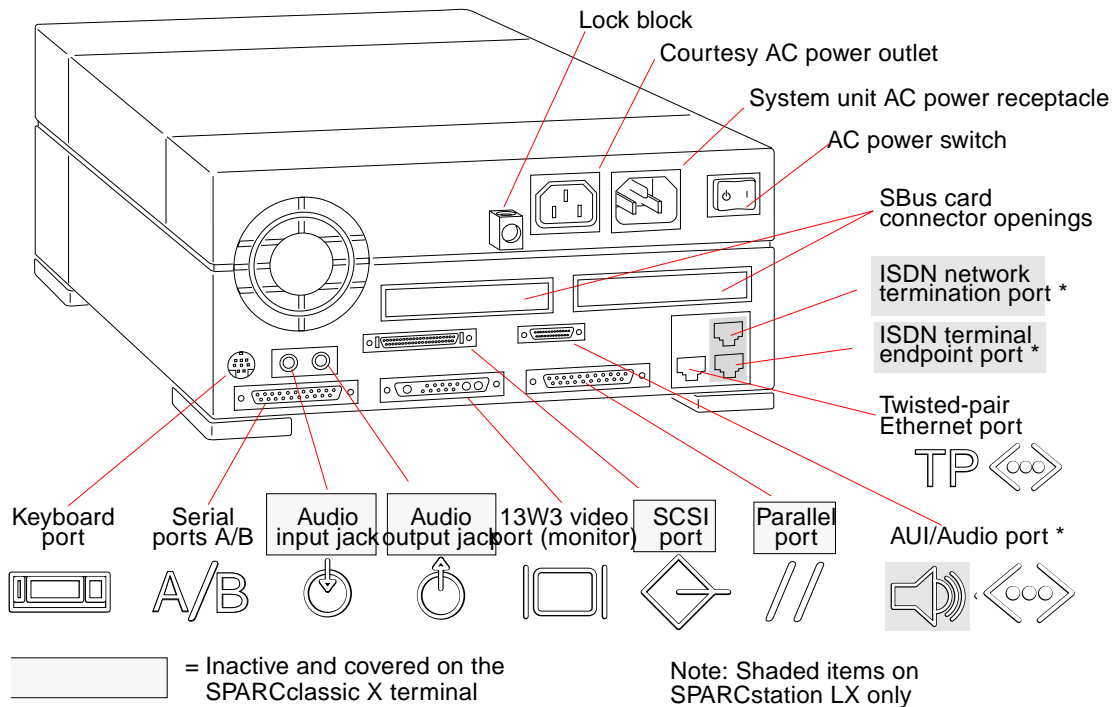

FIGURE 1-2 Rear Panel of the System Unit

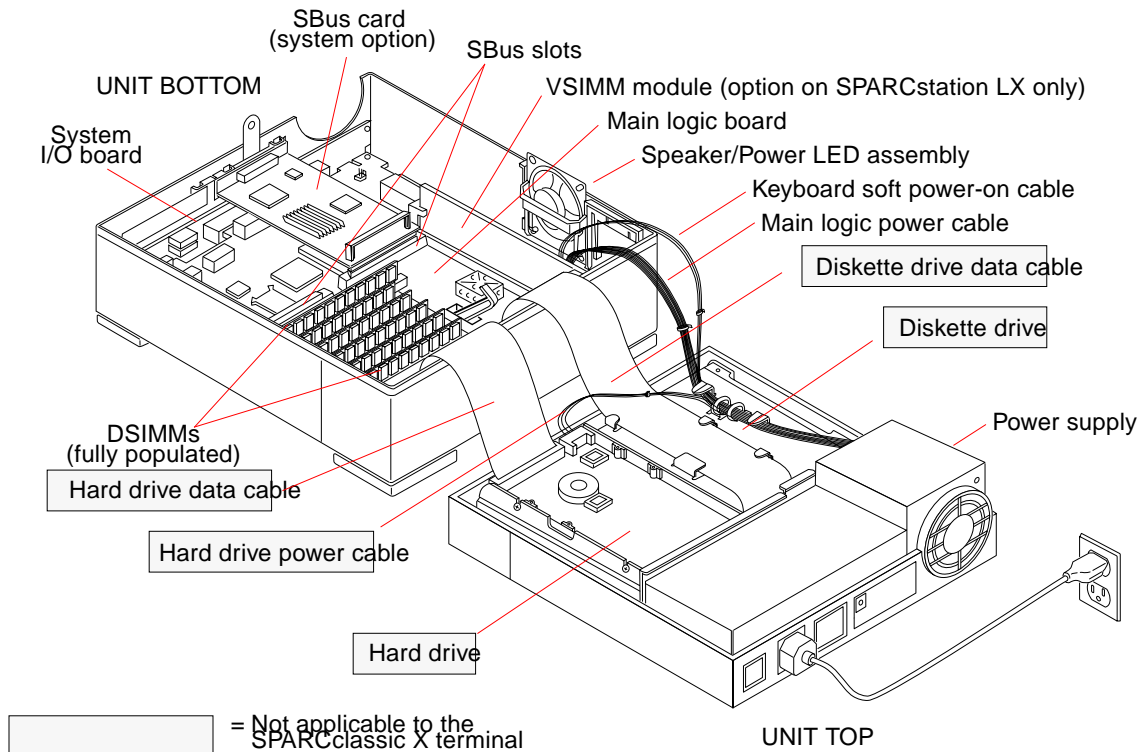

FIGURE 1-3 System Unit Internal Components

1.1.1 Main Logic Board

The main logic board (MLB) resides in the bottom half of the system unit. It plugs into the system input/output (I/O) board, which provides all of the external connectors to the system unit's back panel (see FIGURE 1-2).

The different SPARCclassic/SPARCclassic X/SPARCstation LX MLB layouts are in Chapter 10 "System Board Overview. FIGURE 10-1 shows a simplified layout of the SPARCclassic and the SPARCclassic X main logic board, while FIGURE 10-2 and FIGURE 10-3 show the SPARCstation LX main logic boards.

Customer replaceable units (CRUs) residing on the main logic board include:

- Memory modules
- Video single in-line memory modules (VSIMMs) (SPARCstation LX only)
- SBus cards
- Nonvolatile random access memory (NVRAM)

1.1.2 Memory Modules

SPARCclassic and SPARCstation LX system units come equipped with at least 16 megabytes of dynamic random access memory (DRAM), expandable to 96 megabytes. The X terminal comes with either 4 or 8 megabytes of DRAM, expandable to 96 megabytes.

Physically, DRAM chips are grouped in single in-line memory modules (DSIMMs) that plug into DSIMM slots located on the main logic board of the system unit (see FIGURE 10-1 and FIGURE 10-2). The main logic board contains six DSIMM slots capable of accepting either 1-, 2-, 4-, or 16-megabyte DSIMMs.

The maximum memory configuration is 96 megabytes using six 16-megabyte DSIMMs. You can combine different types of DSIMMs in the same system; however, you must add DSIMMs in identical pairs. That is, you can add a pair of 4-megabyte DSIMMs or a pair of 16-megabyte DSIMMs, but you can't add a single DSIMM or add one of each type.

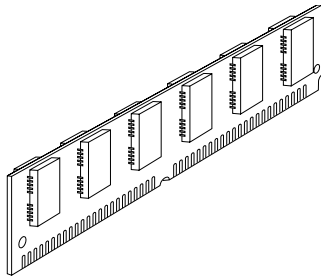

FIGURE 1-4 Typical DSIMM

1.1.2.1 Video SIMM

SPARCstation LX systems can accommodate an optional 1-megabyte video SIMM (VSIMM). The VSIMM plugs into a VSIMM slot on the main logic board and allows SPARCstation LX systems to support the following video display resolutions:

- 1600 x 1280
- 1280 x 1024
- 1152 x 900 double-buffered

1.1.2.2 SBus Cards

You can add various SBus cards to the system's two SBus slots on the main logic board. FIGURE 10-1 and FIGURE 10-2 show the location of the SBus slots. See the Section 11.1 "SBus Cards" on page 11-1 for information about how to remove and replace SBus cards.

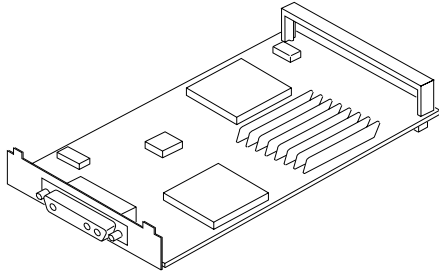

FIGURE 1-5 Typical SBus Card

The following is a sampling of the SBus cards available for SPARCclassic and SPARCstation LX systems. Note that this is not an all-inclusive list.

- *GX Graphics Accelerator Card* – This card controls the video output from the system unit, and accelerates the generation of graphic images. The GX Graphics Accelerator card occupies one SBus slot on the main logic board. (On the SPARCclassic X terminal, the card is supported as a factory-installed option but not as an add-on board.)
- *Color Frame Buffer Card* – This card occupies one SBus slot. This card controls the video output from the system unit to a color monitor.
- *Second Ethernet Card* – This card provides you with an extra Ethernet port. The Ethernet card is used in applications in which your SPARCstation acts as a gateway between two physically distinct Ethernet networks. This card has two connectors: standard (thick) Ethernet and twisted-pair Ethernet. It occupies one SBus slot.
- *Video Frame Capture Card* – This card occupies one SBus slot. This card takes video input and displays it on color or monochrome monitors.
- *SBus Printer Card* – This card occupies one SBus slot. This card connects the system to printing, plotting, and scanning devices.

1.1.3 Nonvolatile RAM (NVRAM)

The NVRAM chip on the main logic board contains the time-of-day clock and the nonvolatile RAM (FIGURE 10-1 and). The nonvolatile RAM stores the default system configuration parameters. These parameters define how the system is configured at the lowest level. You can modify these parameters using the Forth Toolkit. For additional details, see the manual *Open Boot Command Reference*.

1.1.4 Internal Hard Disk Drive

Diskful systems have one 3.5-inch embedded SCSI hard disk drive installed in the top half of the system unit. Depending on your system configuration, the drive may be a 207-megabyte, a 424-megabyte, a 535-megabyte, or a 1.0-gigabyte disk. (The SPARCclassic X terminal is not a diskful system.)

1.1.5 Internal Diskette Drive

The top half of the system unit accommodates a 3.5-inch, triple-density diskette drive, which is Sun™, IBM®, and NEC® compatible. It uses 3.5-inch (88.9-mm) diskettes (types HD, 2HD, and 2DD) and supports densities of 720 kilobytes, 1.2 megabytes, and 1.44 megabytes. The diskette drive is optional on both SPARCclassic and SPARCstation LX systems. It is not available for the SPARCclassic X terminal.

1.1.6 Power Supply

The 70-watt power supply is housed in the unit top. It connects to the main logic board via a 12-pin connector and provides +5, +12, and -12 volts DC. The power supply also supplies the power-on reset signal.

Some of the power supply's features include the following:

- Auto sensing
- Output voltage regulation
- Overcurrent protection
- Overvoltage crowbar feature
- Internal fusing

The external devices have their own power supplies.

1.2 Monitors, Keyboard, and Mouse

Each system uses a keyboard, an optical mouse, and one of the following types of video monitors:

- 15-inch color monitor (381-mm)
- 16-inch mid-range color monitor (407-mm)
- 16-inch premium color monitor (407-mm)
- 19-inch grayscale monitor (483-mm)
- 19-inch color monitor (483-mm)

The main logic board has a built-in frame buffer that controls video output from the system unit and can drive either color or grayscale monitors.

1.3 External Storage Devices

You can add expansion storage devices to increase the mass storage capacity of the SPARCclassic and SPARCstation LX systems. The following are some of the external storage devices available:

- Desktop Backup Pack 150 Mbytes (tape drive only)
- Desktop Disk Pack 207 Mbytes (hard disk drive only)
- Desktop Disk Pack 424 Mbytes (hard disk drive only)
- Desktop SunCD Pack (compact disc drive)
- Desktop Storage Module 1.3 Gbytes (hard disk drive only)
- Desktop Storage Module 2.3 Gbytes (tape drive only)
- Desktop Storage Module 5.0 Gbytes (tape drive only)

See the external storage device installation guide that comes with the device for installation procedures and for information about daisy-chaining external drive units. External storage devices are not available for the SPARCclassic X terminal.

1.4 System Interconnections

FIGURE 1-6 illustrates how to connect the basic components of the SPARCclassic and SPARCstation LX workstations, and the SPARCclassic X terminal. For more detailed installation procedures, see *Desktop SPARC Hardware Owner's Guide or Using a SPARCclassic X Terminal*.

Note – The external drive in FIGURE 1-6 is not part of the SPARCclassic X terminal. See FIGURE 1-2 and FIGURE 1-3 for differences between the SPARCclassic X terminal and the SPARCclassic workstation.

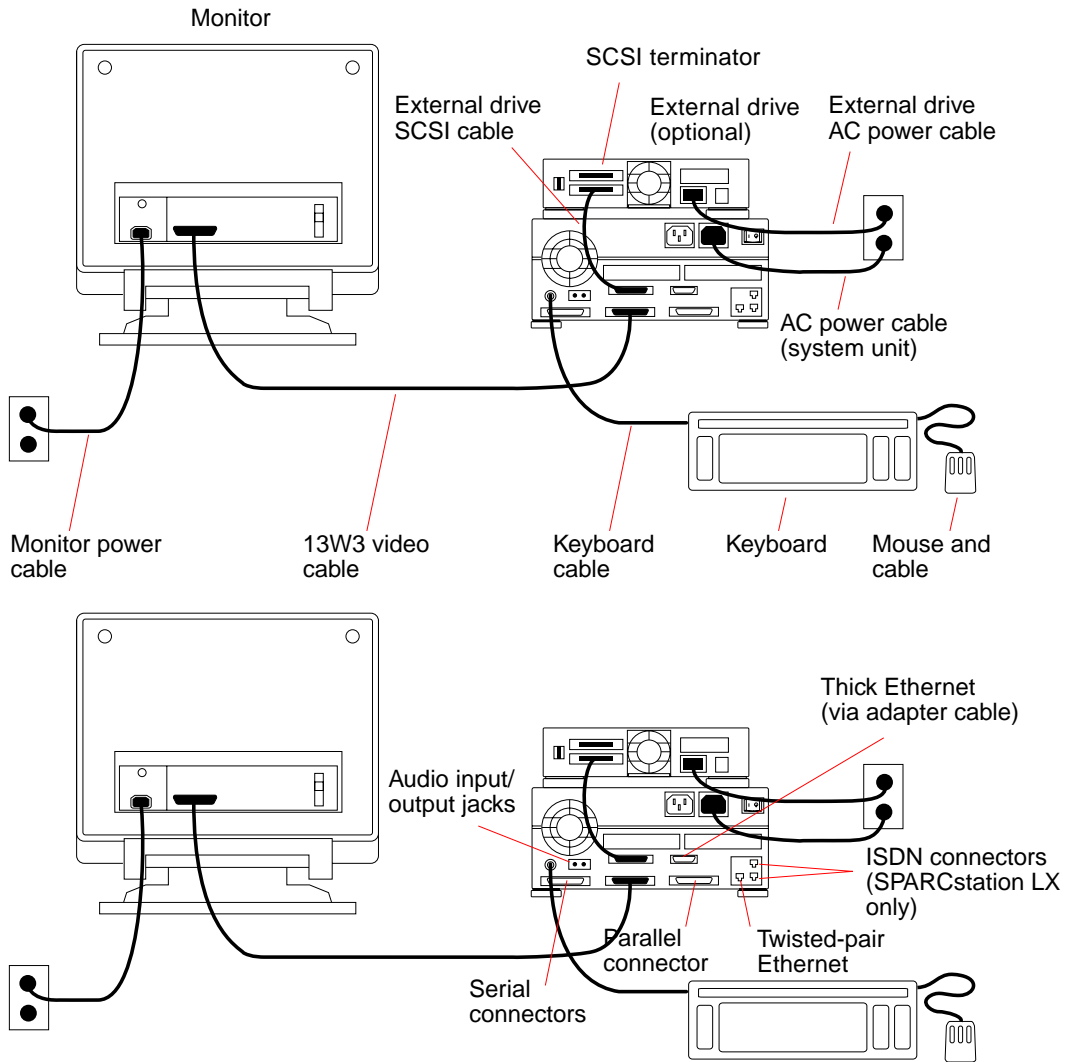

FIGURE 1-6 Connecting the Major System Components

Troubleshooting Overview

This chapter describes the different types of diagnostic firmware and software tools available to you for troubleshooting, and explains how they are related and when to use them.

- Section 2.1 “Default Boot Mode”
- Section 2.2 “Boot PROM Diagnostics”
- Section 2.3 “Low-Level POST Code”
- Section 2.4 “Diagnostic Tools and When to Use Them”
- Section 2.5 “Power-On Self-Test”
- Section 2.6 “Selected On-Board Tests”
- Section 2.7 “Sundiag System Exerciser”
- Section 2.8 “Forth Toolkit”
- Section 2.9 “SunDiagnostic Executive”

2.1 Default Boot Mode

The flowchart in FIGURE 2-1 outlines the roles played by various diagnostics during the default boot mode’s operation.

Note – The operating system diagnostic tools, as indicated in FIGURE 2-1, do not apply to the SPARCclassic X terminal.

2.2 Boot PROM Diagnostics

The diagnostics are stored in the Open Boot PROM and include the following:

- Power-On Self-Test
- On-Board Diagnostics

The Power-On Self-Test (POST) tests the core CPU functionality. The progress of testing can be monitored using the keyboard LEDs, the video monitor, and the system's serial port A.

If there is system trouble, you may want to run the extended On-Board Diagnostics to take advantage of more extensive tests, including—but not limited to—Ethernet, SCSI, memory, and diskette drive tests. See Appendix C “On-Board Diagnostics,” for more information.

Note – The SCSI and diskette drive controller tests do not apply to the SPARCclassic X terminal.

The following sections describe the relationship between the various diagnostic tools and the role each tool plays during the default boot mode. A graphical depiction is provided by the flowchart in FIGURE 2-1. The figure shows the path followed in processing for the default boot mode, and where in the sequence other diagnostic tests are available or are encountered. These descriptions assume you are using a graphics monitor to view test results.

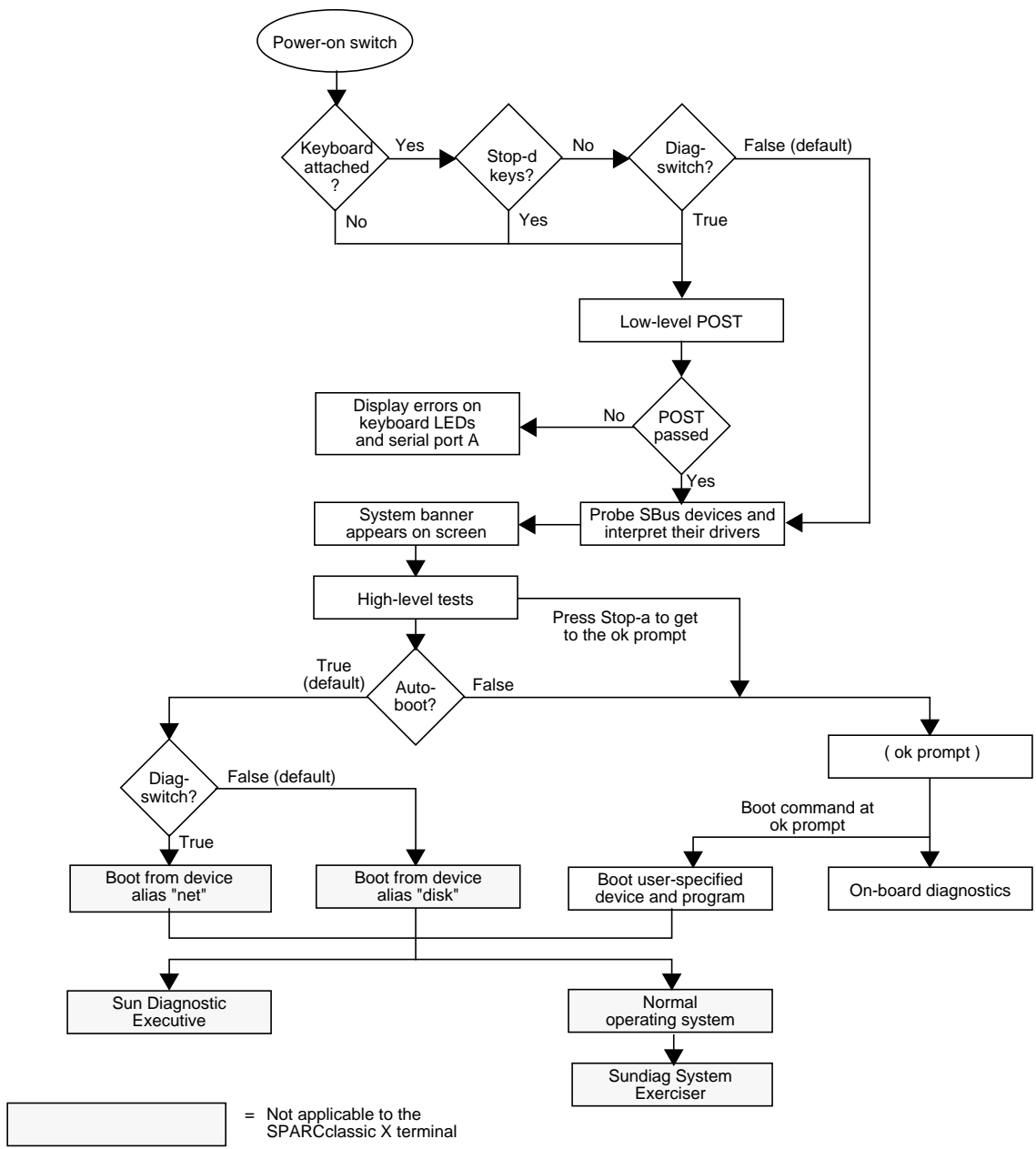

FIGURE 2-1 Default Boot Mode

2.3 Low-Level POST Code

When you turn on the system power, the low-level POST is initiated if any of the following circumstances apply:

- Keyboard is disconnected.
- Stop-d keys are held down when you turn on the power.
- `diag-switch?` NVRAM parameter is set to True.

The low-level POST code, which is stored in the boot PROM, is designed to test the most basic functions of the system hardware. The status of the POST is conveyed by four LEDs on the Type-5 keyboard. The Caps Lock LED flashes on and off to indicate that the tests are in progress. If a failure is detected during low-level POST, one of the other three LEDs will light to indicate the nature of the failure. See Chapter 3 “Power-On Self-Test (POST),” for more information.

If the low-level POST passes, the system probes for SBus devices and interprets their drivers. Next, a system banner appears on the screen, and the high-level testing begins. During this time, the screen displays a series of messages that start with the word `Testing`. Any problems detected during this phase of testing are indicated with error messages on the screen. When the high-level POSTs are finished, the system checks parameters stored in the NVRAM to determine the next step. Depending on the parameter settings, the system will:

- Boot the operating system from a specified location
- Continually cycle through the POST sequence
- Suppress the boot process and enter the Forth Toolkit (`ok` prompt)
- Suppress the boot process and enter the system monitor (`>` prompt)

TABLE 2-1 contains a list of NVRAM parameters and explains their effect on the power-up sequence. For more on NVRAM parameters, see the *Open Boot Command Summary*.

Note – At any point during the high-level POST, you can abort the POST process and access the Forth Toolkit or system monitor by pressing the Stop and “a” keys simultaneously.

TABLE 2-1 NVRAM Parameters Used During POST and Boot Sequence

NVRAM Parameter	Description
selftest-#megs Default = 1	This parameter determines how many megabytes of memory to test during high-level POST. The minimum is zero; the maximum is the amount actually installed in the system.
diag-switch? Default = False	When set to True, this parameter forces the system to test automatically all available memory. It also enables diagnostic message output to serial port A. If a properly configured terminal or “tip window” is connected, diagnostic progress can be monitored through this port. Finally, a True setting causes the system to boot the operating system from the device and file specified in the <code>diag-device</code> and <code>diag-file</code> NVRAM parameter fields.
auto-boot? Default = True	When set to False, this will suppress the boot process. The system halts with either the <code>></code> prompt or the <code>ok</code> prompt.

If the `auto-boot?` parameter is set to `false`, the system proceeds to the Forth Toolkit (`ok` prompt), or to the system monitor (`>` prompt). Using the Forth Toolkit, you can direct the system to boot the operating system from a location that you specify, or you can execute a variety of additional tests called On-Board Diagnostics. See the *Open Boot Command Reference* for a complete description of the Forth Toolkit.

If the `auto-boot?` parameter is set to `true` (the default), the system boots a standalone program. To determine which program and device to boot from, the system checks the `diag-switch?` NVRAM parameter. TABLE 2-2 summarizes the effect of the `auto-boot?` and `diag-switch?` parameters.

TABLE 2-2 Summary of Autoboot and Diagnostic Switch Parameters ¹

Autoboot Switch Parameter	Diagnostic Switch Parameter	Result
False	False or True	<code>></code> or <code>ok</code> prompt
True	False	Boot operating system from device alias “disk” or “net” for SPARCclassic X
True	True	Boot operating system from device alias “net”

1. The boot parameters represented here are default settings. The defaults may be changed by following the procedures listed in the *Open Boot Command Summary*.

Once the operating system is running, you can invoke the Sundiag System Exerciser if further diagnostic testing is warranted. Refer to Section 2.7 “Sundiag System Exerciser” on page 2-9 for additional information.

Another standalone diagnostic program you can run is the SunDiagnostic Executive. Refer to Section 2.9 “SunDiagnostic Executive” on page 2-10 for further information.

To boot user-specified programs, such as the SunDiagnostic Executive, you must be at the > prompt or ok prompt. See Appendix C “On-Board Diagnostics” for a detailed procedure on how to access the > or ok prompt.

Note – Remember that the System Exerciser and the SunDiagnostic Executive do not run on the SPARCclassic X terminal.

2.4 Diagnostic Tools and When to Use Them

TABLE 2-3 provides a summary of the available diagnostic tools and describes when to use each tool.

TABLE 2-3 Diagnostic Tools

Diagnostic Tool	When or Why to Use the Tool
Power-On Self-Test (POST)	Executes automatically at power-on when Stop-d keys are pressed or when the <code>diag-switch?</code> parameter is set to True. The POST code resides in the boot PROM and is driven by the POK signal from the power supply. POST tells you if there is a problem with the main logic board, the NVRAM, or the DSIMMs in the default bank installed.
On-Board Diagnostics	Tests functions such as the Ethernet and SCSI interfaces, system memory, and the diskette drive controller. (The SCSI and diskette drive controller tests do not apply to the SPARCclassic X terminal.) You must be at the <code>ok</code> prompt (the Forth Toolkit) to run the On-Board Diagnostics. Enter <code>n</code> at the <code>></code> prompt to enter the Forth Toolkit. The On-Board Diagnostics reside in the boot PROM.
Sundiag System Exerciser	Runs under the operating system. It displays real-time use of the system resources and peripherals. The Sundiag System Exerciser tells you if your system is functioning correctly. If Sundiag fails, run the Power-On Self-Test. If all power-on self-tests pass, then run the SunDiagnostic Executive to identify the problem. See the <i>Sundiag User's Guide</i> for more information. (This test is not applicable to the SPARCclassic X terminal.)
Forth Toolkit	Allows input to the system at the boot PROM level. Supports functions such as changing NVRAM parameters, resetting the system, running diagnostic tests, displaying system information, and redirecting input and output. See the <i>Open Boot Command Reference</i> for more information.
SunDiagnostic Executive	Runs extensive, configurable subsystem tests that are independent of the operating system. Run the SunDiagnostic Executive if all tests pass when you run the POST. Running the SunDiagnostic Executive allows you to determine which customer replaceable unit needs to be replaced. See the latest version of <i>SunDiagnostic Executive User's Guide for the SPARCstations</i> for more information. (This test is not applicable to the SPARCclassic X terminal.)

2.5 Power-On Self-Test

For more information about the POST, see Chapter 3 “Power-On Self-Test (POST).”

2.6 Selected On-Board Tests

For information about how to run the On-Board Diagnostics, see Appendix C “On-Board Diagnostics.” TABLE 2-4 lists specific on-board diagnostic tests for SPARCclassic and SPARCstation LX systems.

TABLE 2-4 On-Board Diagnostics

Test	Description and Requirements
test floppy	Tests the floppy drive's ability to respond to commands. Requires a formatted diskette in the drive.
test screen	Tests the system video graphics hardware and monitor. The <code>diag-switch?</code> NVRAM parameter must be set to True for the test to run.
test scsi	Tests the SCSI logic on the main logic board. The <code>diag-switch?</code> NVRAM parameter must be set to True for the test to run.
test net-aur	Performs internal and external loopback tests on the AUI (thick) Ethernet interface. A cable must be connected to the system AUI Ethernet port and to an Ethernet tap, or the test will fail the external loopback phase.
test net-tpe	Performs internal and external loopback tests on the twisted-pair Ethernet (TPE) interface. A cable must be connected to the system TPE port and to a TPE hub, or the test will fail the external loopback phase. If the <code>tpe-link-test?</code> parameter is False (disabled), the external loopback test will appear to pass even if a cable is not connected.
test net	Performs internal and external loopback tests on the auto-selected system Ethernet interface. A cable must be attached to the system and to an Ethernet tap or hub, or the external loopback test will fail.
test disk test disk0 test disk1 test disk2 test disk	Tests internal or external SCSI disks that have a self-diagnostic program contained in the drive controller. The drive must be spinning before this test is executed or the test will fail. Enter a <code>boot <disk alias></code> command to cause the drive to spin up. (<code>disk0</code> = SCSI target 0, <code>disk1</code> = SCSI target 1, <code>disk2</code> = SCSI target 2, <code>disk</code> and <code>disk3</code> = SCSI target 3.)
test cdrom	Performs a diagnostic self-test on the CD-ROM drive. The CD-ROM must be set to SCSI target 6 and have a CD inserted or the test will fail.

TABLE 2-4 On-Board Diagnostics (Continued)

Test	Description and Requirements
test tape test tape0 test tape1	Tests the SCSI tape drive by executing the drive self-test program. (tape and tape0 = SCSI target 4, tape1 = SCSI target 5.)
test ttya test ttyb	Test outputs an alphanumeric test pattern on the system serial ports. (ttya = serial port A, ttyb = serial port B.) You must attach a terminal to the tested port to observe the output.
test keyboard	This test executes the keyboard self-test. The four LEDs on the keyboard should flash on at once, and this message is displayed: Keyboard Present.

2.7 Sundiag System Exerciser

Use the Sundiag System Exerciser to determine real-time use of system resources and peripheral equipment such as Desktop Storage Modules and External Storage Modules. The Sundiag System Exerciser verifies that the system is functioning properly. For information about how to use the Sundiag System Exerciser, see the *Sundiag User's Guide*.

If Sundiag passes, the system is operating properly. If Sundiag fails, the error messages should indicate the part of the system that has failed. If the error messages are not descriptive enough, you may need to run POST or the SunDiagnostic Executive.

Note – The Sundiag System Exerciser is not applicable to the SPARCclassic X terminal.

2.8 Forth Toolkit

The Forth Toolkit is a basic diagnostic utility and system interface. If there is any problem with your operating system, the Forth Toolkit automatically starts, as indicated by the appearance of the `ok` prompt.

You can also choose to access the Forth Toolkit by halting the system. For information on how to access the Forth Toolkit, see Appendix C “On-Board Diagnostics.”

For extensive information about tests you can run from the Forth Toolkit, see *Open Boot Command Reference*.

2.9 SunDiagnostic Executive

The SunDiagnostic Executive is an independent operating system. It runs exhaustive subsystem tests that are independent of the normal operating system. Run the SunDiagnostic Executive if all POSTs pass, but your system still has a problem. For information about POST, see Section 3.1 “Power-On Self-Test (POST)” on page 3-1. The SunDiagnostic Executive is described in the *SunDiagnostic Executive User’s Guide for the SPARCstations*.

Note – The SunDiagnostic Executive is not applicable to the SPARCclassic X terminal.

Power-On Self-Test (POST)

This chapter describes the Power-On Self-Test (POST) for normal, full, and abbreviated modes, available with your SPARCclassic and SPARCstation LX.

- Section 3.1 “Power-On Self-Test (POST)”
- Section 3.2 “Normal Mode”
- Section 3.3 “Full Diagnostic Mode”
- Section 3.4 “Abbreviated Diagnostic Mode”
- Section 3.5 “Tests the POST Runs”
- Section 3.6 “POST Error Messages”
- Section 3.7 “Status Lights (LEDs) and Indicators”

The Power-On Self-Test (POST) diagnostics reside in the Open Boot PROM located on the system board. There are two POST modes: Normal and Diagnostic.

3.1 Power-On Self-Test (POST)

The Power-On Self-Test (POST) runs when you turn on the system unit power switch and any of the following conditions apply:

- Keyboard is disconnected.
- Stop-d keys are held down when you turn on the power.
- `diag-switch?` NVRAM parameter is set to `true`.

The POST comprises a sequence of tests designed to evaluate the major hardware components of the main logic board in the short time before the operating system is booted. The POST does not perform extensive testing on any component of the main logic board. Only major failures can be detected by the POST.

Four different LEDs on the keyboard are used to indicate the progress and results of the POST. These LEDs are on the Caps Lock, Compose, Scroll Lock, and Num Lock keys, as shown in FIGURE 3-1. To indicate the beginning of the POSTs, the four LEDs briefly light all at once. The monitor screen remains blank, and the Caps Lock LED flashes for the duration of the POST.

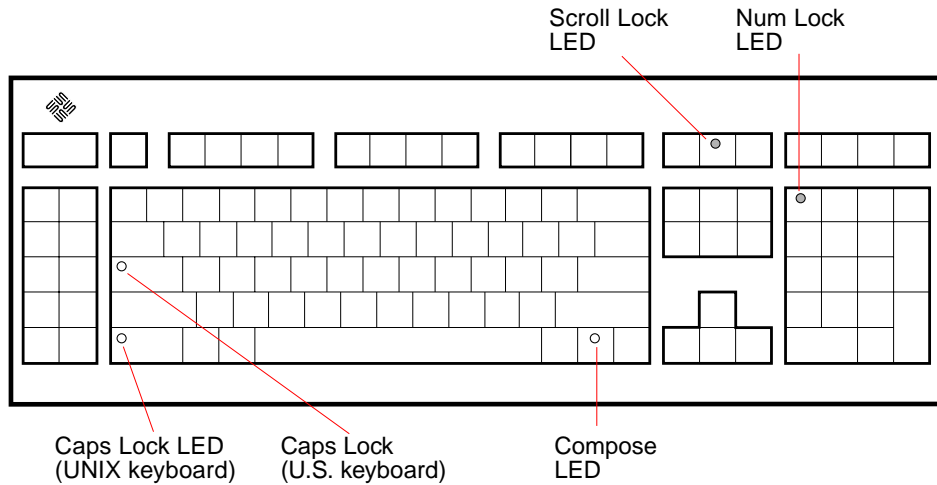

FIGURE 3-1 Arrangement of Type-5 Keyboard Diagnostic LEDs

If the system fails any POST, one of the LEDs will light to indicate the nature of the problem. The LED may be lit continuously, or for just a few seconds. TABLE 3-1 provides the meaning of each diagnostic LED.

TABLE 3-1 Interpreting the Keyboard Diagnostic LEDs

Diagnostic LED	Failed Part
Num Lock LED is lit.	Main logic board
Scroll Lock LED is lit.	NVRAM
Compose LED is lit.	DSIMM U0303 or U0304
Compose LED is lit (ROM 2.14 or later).	Last installed memory bank

Note – The Caps Lock LED is *not* used as a failure indicator; it flashes on and off to indicate that the POSTs are running. The keyboard LED diagnostics feature described here applies only to a SPARCclassic or SPARCstation LX system with a Sun Type-5 keyboard connected to its keyboard port. The LED diagnostics feature does not apply if a different keyboard is connected to the keyboard port, or if a terminal and its keyboard are used as a main console instead of a monitor and Sun Type-5 keyboard.

If the system passes all the POSTs, all four LEDs light again and then go off. Next the system banner appears on the screen. The SPARCstation banner is shown as an example; the SPARCclassic X terminal banner will be different. From this point on, the keyboard LEDs assume their normal functions (that is, you should no longer interpret the LEDs as diagnostic error indicators).

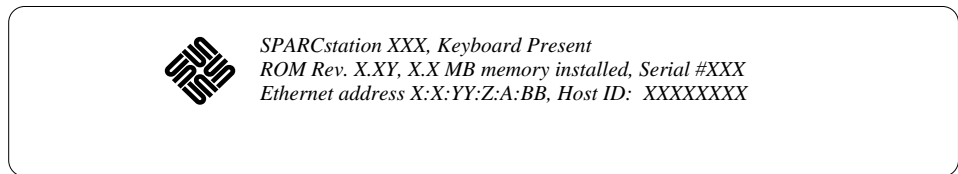

FIGURE 3-2 SPARCstation System Banner

Following the system's successful initialization, the operating system is booted automatically—unless the NVRAM configuration options specify otherwise.

You can retrieve more detailed POST failure information by connecting a terminal to the ttya serial port. If you connect a terminal, you must set the NVRAM parameter `diag-switch?` to `true`. For more information about the NVRAM parameters, see TABLE 2-1 on page 2-5. Test failure messages are displayed on the system monitor whether or not the system is in Diagnostic mode. However, it may be easier to understand the failure message output when it is accompanied by more detailed POST progress messages available via the ttya serial port.

An example of a POST failure message output over the ttya serial port is shown below.

```
FAILURE:  NVRAM    (f2000003)  Battery Failure, Exp = 00000000  Obs = 0000000a
```

3.2 Normal Mode

Under Normal mode, when the system is turned on, control is sent to the Open Boot PROM. Depending on the options set in the Open Boot PROM, for example if autoboot is enabled (set to `true`), the operating system will load. Diagnostic testing is *not* run.

3.3 Full Diagnostic Mode

Diagnostic mode, is the mode which tests the major hardware system board components and, if the POST is successful, probes the installed SBus modules. Diagnostic mode runs if *one* of these conditions is met:

- You press and hold the Stop-d keys while you turn the on the power
- You set the `diag-switch?` NVRAM parameter to `true` in the Open Boot PROM
- You disconnect the keyboard and you set the `diag-switch?` NVRAM parameter to `true` in the Open Boot PROM

Note – POST does not perform extensive testing on any system board component. POST detects only major failures.

To view error messages returned by POST, connect a terminal to serial port A or use a `tip` connection to another workstation.

If you do not connect a terminal to serial port A or use a `tip` connection, the screen will be blank during the POST Diagnostic mode. In this case, use the keyboard LEDs to display error conditions. See Section 3.7 “Status Lights (LEDs) and Indicators.”

3.4 Abbreviated Diagnostic Mode

A brief Power-On Self-Test (POST) is run if you disconnect the keyboard and you set the `diag-switch?` NVRAM parameter to `false` in the Open Boot PROM. The brief Power-On Self-Test is silent (no progressive test messages are printed out). If an error or errors occur during the abbreviated Power-On Self-Test, all error messages are displayed on the TTY or `tip` window.

3.4.1 Setting Up a `tip` Connection to Another Workstation

You can use the serial port on your SPARCstation to connect to another Sun workstation (either the same type of SPARC system or a different type of Sun workstation or server system). This connection lets you use a shell window on the Sun workstation as a terminal to the SPARCstation 10 being tested.

The `tip` method is recommended, because it lets you use SunOS windowing and operating system features to help you work with the boot PROM.

To make a `tip` connection, follow these steps:

1. **Connect the system's serial port (`ttya`) to another Sun workstation `ttya` serial port using a serial connection cable. This connection is made with a 3-wire null modem cable. Connect wires 3-2, 2-3, and 7-7.**
2. **At the other Sun workstation, add the following lines to the file `/etc/remote`:**

```
hardwire:\
:dv=/dev/ttya:br#9600:el=^C^S^Q^U^D:ie=%$:oe=^D:
```

3. **In a Shell Tool window on the Sun workstation, type `tip hardwire`. (Some commands will not work properly in a Command Tool window.)**

The system will reply `connected`.

```
hostname% tip hardwire
connected
```

The Shell window is now a `tip` window directed to the Sun workstation serial port.

4. **When you are finished running POST and want to disconnect the `tip` window, type `kill -9` and the process ID number of the `tip hardwire` process.**

```
hostname% kill -9 PID# of tip hardwire process
```

3.5 Tests the POST Runs

Following is a sample listing of the full diagnostic mode tests completed by POST.

TABLE 3-2 Listing of POST Tests

MMU Context Table Reg Test
MMU Context Register Test
MMU TLB Replace Ctrl Reg Tst
MMU Sync Fault Stat Reg Test
MMU Sync Fault Addr Reg Test
MMU TLB RAM NTA Pattern Test
MMU TLB CAM NTA Pattern Test
IOMMU SBUS Config Regs Test
IOMMU Control Reg Test
IOMMU Base Address Reg Test
IOMMU TLB Flush Entry Test
IOMMU TLB Flush All Test
SBus Read Time-out Test
EBus Read Time-out Test
D-Cache RAM NTA Test
D-Cache TAG NTA Test
I-Cache RAM NTA Test
I-Cache TAG NTA Test
Memory Address Pattern Test
FPU Register File Test
FPU Misaligned Reg Pair Test
FPU Single-precision Tests
FPU Double-precision Tests
FPU SP Invalid CEXC Test
FPU SP Overflow CEXC Test
FPU SP Divide-by-0 CEXC Test

TABLE 3-2 Listing of POST Tests (*Continued*)

FPU SP Inexact CEXC Test
FPU SP Trap Priority > Test
FPU SP Trap Priority < Test
FPU DP Invalid CEXC Test
FPU DP Overflow CEXC Test
FPU DP Divide-by-0 CEXC Test
FPU DP Inexact CEXC Test
FPU DP Trap Priority > Test
FPU DP Trap Priority < Test
PROC0 Interrupt Regs Tests
Soft Interrupts OFF Test
Soft Interrupts ON Test
PROC0 User Timer Test
PROC0 Counter/Timer Test
DMA2 E_CSR Register Test
LANCE Address Port Tests
LANCE Data Port Tests
DMA2 D_CSR Register Test
DMA2 D_ADDR Register Test
DMA2 D_BCNT Register Test
DMA2 D_NADDR Register Test
ESP Registers Tests
DMA2 P_CSR Register Test
DMA2 P_ADDR Register Test
DMA2 P_BCNT Register Test
PPORT Registers Tests
NVRAM Access Test
TOD Registers Test

3.6 POST Error Messages

The POST error messages returned to the terminal are self-explanatory. For example, if no DSIMM is installed in the system, POST will tell you that no DSIMM is installed and the slot number of the SIMM slot. Use the error messages returned by POST to troubleshoot the system.

3.7 Status Lights (LEDs) and Indicators

The LED at the front of the chassis lights up when the system is operating normally. FIGURE 3-3 shows the location of the system LED. Chapter 4 “Troubleshooting Procedures,” shows flow diagrams of actions to take when the system LED is not lit.

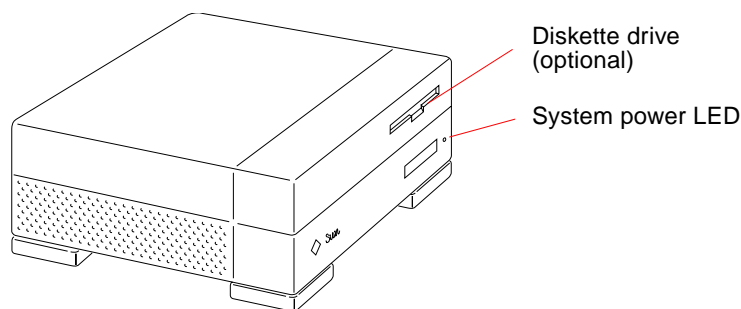

FIGURE 3-3 System Power LED on Front of System

This section describes the keyboard LED sequences displayed at power up when POST fails. If a failure occurs in POST, the keyboard displays a specific LED pattern. See FIGURE 3-4 and TABLE 3-1. During normal system operation, the LEDs should not be interpreted as diagnostic error indicators.

Following the system initialization, the operating system boots automatically, unless the NVRAM configuration options specify not to do so.

Note – The Caps Lock key LED, located just above the left-hand Shift key, is not used as a power-on test failure indicator, but flashes on and off while POST is running.

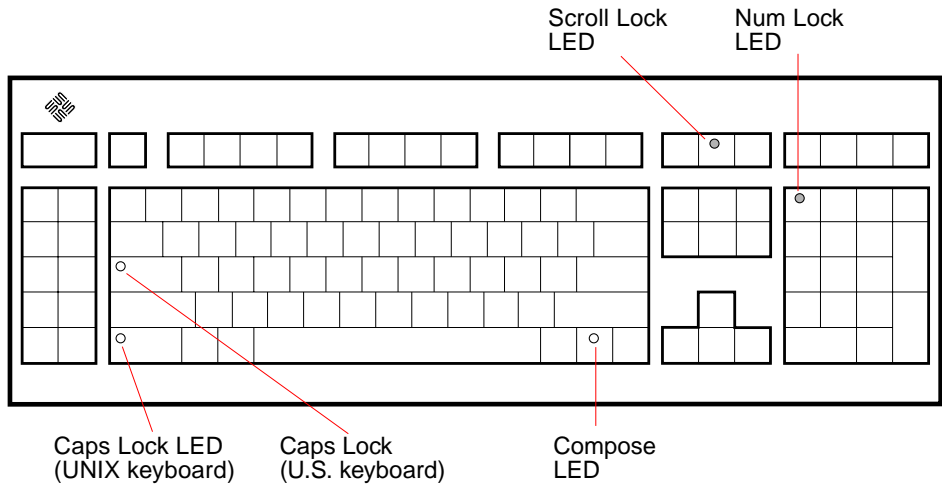

FIGURE 3-4 Arrangement of the Type-5 Keyboard LEDs

If the Caps Lock key fails to flash on and off after you have pressed and held the Stop-d keys when you power on the system, POST failed. See Section 4.2.2 “System Board Test” for troubleshooting information.

Troubleshooting Procedures

This chapter describes how to troubleshoot SPARCclassic and SPARCstation LX system problems. Each problem is described, and a set of procedures is provided for a solution to the problem.

- Section 4.1 “No Video Output on the System Monitor”
- Section 4.2 “Power-On Does Not Succeed”
- Section 4.3 “Disk Drive Errors”
- Section 4.4 “Determining Faulty DSIMM Locations”

TABLE 4-1 describes commonly encountered troubleshooting problems, and tips for solving them.

TABLE 4-1 Troubleshooting Tips

Problem	Action
LED on front of system is not lit.	Verify that the power switch is turned on and that the power cord is connected. If both the power switch and the power cord are connected, shut down the system and verify that the LED cable is connected. If the LED cable is connected, the power supply is defective. Replace the power supply. See Chapter 8 “Major Subassemblies.”
Disk drive fails to boot or does not respond.	Shut down the system. The SCSI controller may be defective. See Section 4.3.1 “Verifying the Built-In SCSI Controller.” If the SCSI controller is OK, verify that SCSI ID jumpers are set correctly and that every disk drive on the SCSI bus is set to a different SCSI address. Verify that the configuration jumpers on the disk drive are set correctly. See Chapter 9 “Storage Devices.”
Operating system does not recognize disk drive at boot up.	Shut down the system. Verify that SCSI ID jumpers are set correctly and that every disk drive on the SCSI bus is set to a different SCSI address. Verify that the configuration jumpers on the disk drive are set correctly. See Chapter 9 “Storage Devices.”
No video output on monitor.	Verify that the power cord is connected. Use a Volt Ohmmeter (VOM) to check voltages. See Section 4.1 “No Video Output on the System Monitor.”

TABLE 4-1 Troubleshooting Tips (Continued)

Problem	Action
Slow disk drive response.	If many SCSI devices are connected to the same SCSI bus and if some of these devices are “fast SCSI” devices, you can install an FSBE/S SBus card to the “fast SCSI” devices to speed up performance.
Read, write, or parity error reported by the operating system or applications.	Replace the disk drive indicated by the failure message. The operating system identifies the internal disk drive 0 (SCSI target ID 3) as <code>sd0</code> and internal disk drive 1 (SCSI target ID 1) as <code>sd1</code> .
Power on does not succeed. LEDs on keyboard do not light and there is no tone from the keyboard when you turn on the system power.	The power supply may be defective. See Section 4.2.1 “Power Supply Test.”
Power on does not succeed. The system fails to initialize but the LEDs on the keyboard light and there is a tone from the keyboard.	The system board may be defective. See Section 4.2.2 “System Board Test.”

4.1 No Video Output on the System Monitor

1. **Check that the power cord is connected to the monitor and to the wall outlet.**
2. **Verify that the wall outlet is supplying AC power to the monitor.**
Use a Volt Ohmmeter (VOM).
3. **Verify that the video cable connection is secure between the monitor and the system video output port.**
Use a VOM to perform the continuity test on the video cable.
If the power cord and video cable connection are good and there is still no video output, reseat the video card for the monitor.
4. **If the monitor power supply is internally fused, check the fuse.**
The fuse could be blown.

4.2 Power-On Does Not Succeed

1. **Turn off the system power switch.**

2. Check that the system power cord is properly connected to the system rear panel power receptacle and to the wall outlet.

3. Verify with a VOM that the wall outlet is supplying AC power to the system.

4. Turn the system power switch on and observe the keyboard.

The LEDs on the keyboard should briefly light. You should hear a tone from the keyboard.

If you hear no tone or see no lights on the keyboard, the system's power supply may be defective. See Section 4.2.1 "Power Supply Test."

If you hear a tone and see lights on the keyboard, but the system still fails to initialize, see Section 4.2.2 "System Board Test."

5. If the system power supply is internally fused, check the fuse.

The fuse could be blown. If the power supply is working, you should hear the fans humming.

4.2.1 Power Supply Test

1. Use a VOM (Volt Ohmmeter) to check the power supply output voltages.

Place the VOM negative probe on one of the logic ground pins in the connector, and test the +12V, -12V, and +5.1V power pins individually with the positive probe (pins 1 through 7). See FIGURE 4-1.

Note – The power supply connector (J1401 for SPARCclassic and SPARCclassic X or J1601 for SPARCstation LX) must remain connected to the system board.

2. Replace the power supply assembly if any of the voltages are not present.

See Section 8.1 "Power Supply."

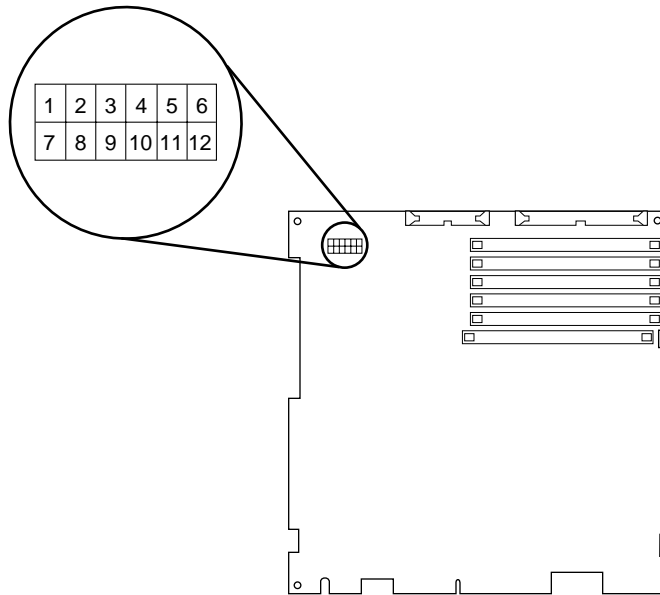

FIGURE 4-1 Power Supply Connector

TABLE 4-2 shows the pin assignments on the power supply connector.

TABLE 4-2 Power Supply Connector Pin Assignments

Pin	Description	Pin	Description
1	+5 Vdc	7	+5 Vdc
2	+5 Vdc	8	+5 Vdc
3	Ground	9	Ground
4	Ground	10	Ground
5	+12 Vdc	11	+12 Vdc
6	POK	12	-12 Vdc

4.2.2 System Board Test

1. **Connect a terminal to serial port A or use a tip connection to another workstation to receive additional POST failure information.**

To set up a tip connection to another workstation, see Section 3.4.1 “Setting Up a tip Connection to Another Workstation.”

2. **Press and hold the Stop-d keys. While holding the keys down, turn the system power switch on. Watch the keyboard LEDs.**
 - a. **The Caps Lock key on the keyboard should flash on and off, indicating that the system is running the Power-On Self-Test (POST).**

If the Caps Lock key fails to flash on and off after you have pressed and held the Stop-d keys, POST failed.
 - b. **To further troubleshoot the system board, see Section 4.2.2.1 “Caps Lock Key Fails to Flash On and Off During POST.”**

3. **Observe the keyboard LEDs.**

If a failure occurs during POST, an LED may light up. TABLE 3-1 in Chapter 3 “Power-On Self-Test (POST), describes types of problems that occur when an LED on the keyboard lights up.

4. **Replace the defective part indicated.**

4.2.2.1 Caps Lock Key Fails to Flash On and Off During POST

1. **Remove optional SBus cards and SIMMs.**

Leave a pair of SIMMs in Bank 1.

2. **Run POST again before replacing the system board.**

Remove all other parts to eliminate the possibility that parts you removed could cause the POST failure.

4.3 Disk Drive Errors

TABLE 4-3 presents disk drive error conditions and corrective actions.

TABLE 4-3 Troubleshooting Disk Drive Errors

Symptom	Corrective Action
Read, write, or parity error reported by the operating system or applications.	Replace the disk drive indicated by the failure message. The operating system identifies the internal disk drive 0 (SCSI target ID 3) as <code>sd0</code> and internal disk drive 1 (SCSI target ID 1) as <code>sd1</code> .
Drive fails to boot or does not respond to commands.	SCSI controller may be defective. See Section 4.3.1 “Verifying the Built-In SCSI Controller.” If SCSI controller is OK, the SCSI ID jumpers or configuration jumpers may be set incorrectly. Refer to Chapter 9 “Storage Devices.”
Slow disk drive response.	If many SCSI devices are connected to the same SCSI bus and if some of these devices, such as the 1.05-Gbyte disk drive, are “fast SCSI” devices, you may want to install an FSBE/S SCSI host adapter card to the “fast SCSI” devices and put these “fast SCSI” devices on a separate SCSI bus to speed up disk drive response.

4.3.1 Verifying the Built-In SCSI Controller

To check whether the built-in SCSI controller is defective, test the drive response to the `probe-scsi` command. To test additional SCSI host adapters added to the system, use the `probe-scsi-all` command. Refer to Section C.1.5 “Probe-scsi, Probe-scsi-all” on page C-7.

- At the `ok` prompt, type `probe-scsi`.

See the following example.

```
ok probe-scsi
Target 1
  Unit 0  Disk SEAGATE ST1480  SUN0424  Copyright  (c) 1991
Target 3
  Unit 0  Disk SEAGATE ST1480  SUN0424  Copyright  (c) 1991
```

- a. **If the disk drive responds and a message is displayed, the system SCSI controller has successfully probed the devices.**

This indicates that the system board is working correctly.

- b. **If a disk doesn't respond:**

- i. **Verify that the SCSI target ID is set correctly. Make sure that every SCSI disk and other SCSI device on the SCSI bus has a different SCSI target ID.**
- ii. **Verify that all SCSI cables and the SCSI terminator are connected securely.**
- iii. **Check the SCSI cables to make sure there are no bent pins.**
- iv. **If you have not found the problem, after checking the previous causes, replace the unresponsive drive.**
- v. **If the problem still occurs after replacing the drive, replace the system board.**
- vi. **If replacing the disk drive and the system board does not correct the problem, replace the internal disk drive cable assembly.**

4.4 Determining Faulty DSIMM Locations

The Sundiag System Exerciser, SunDiagnostic Executive, and POST diagnostics can report memory errors encountered during program execution. For general information about diagnostics see Chapter 2, “Troubleshooting Overview.” Memory error messages on the video monitor usually indicate a physical memory address where the error was detected.

Depending on the diagnostic program you are running, a DSIMM location number (“U” number) or a memory address may be displayed. If the error message displays the location number (see FIGURE 4-2 for DSIMM location numbers), follow the instructions in Section 11.3.2 “Removing a DSIMM” on page 11-13 for removing the defective DSIMM at the numbered location. To replace the DSIMM, follow the directions in Section 11.3.3 “Replacing a DSIMM” on page 11-15.

If the error message displays a physical memory address, consult TABLE 4-4 or TABLE 4-5—depending on your DSIMMs’ capacity—to see which memory bank contains the physical address.

Then, look up the last digit of the address in TABLE 4-6 to find out which of the two DSIMMs in that bank caused the memory error.

For example, in a system using 16-Mbyte DSIMMs, if an error is detected at physical memory address 12fe958, TABLE 4-4 shows that the error occurred in memory bank 1 (DSIMMs U0304 and U0303). TABLE 4-6 then shows that the defective DSIMM is in slot U0304. Follow the instructions in Section 11.3.2 “Removing a DSIMM” on page 11-13 for removing the defective DSIMM at that location. Then, to install the replacement, follow the instructions in Section 11.3.3 “Replacing a DSIMM” on page 11-15.

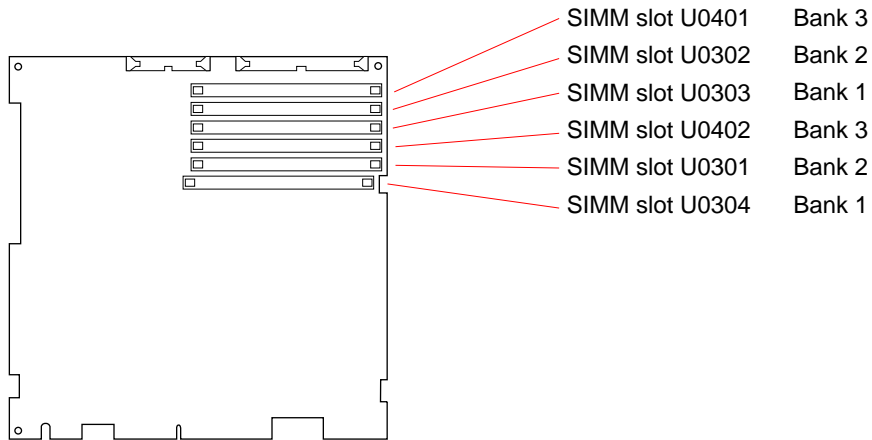

FIGURE 4-2 DSIMM Slot Locations

TABLE 4-4 Physical Memory Address Ranges for 4-Mbyte and 16-Mbyte SIMMs

Bank	SIMM #	Physical Memory Address Ranges	
		4-Mbyte SIMMs	16-Mbyte SIMMs
1	U0304	0000000 through 07FFFFFF	0000000 through 1FFFFFFF
1	U0303	0000000 through 07FFFFFF	0000000 through 1FFFFFFF
2	U0301	2000000 through 27FFFFFF	2000000 through 3FFFFFFF
2	U0302	2000000 through 27FFFFFF	2000000 through 3FFFFFFF
3	U0402	4000000 through 47FFFFFF	4000000 through 5FFFFFFF
3	U0401	4000000 through 47FFFFFF	4000000 through 5FFFFFFF

TABLE 4-5 Physical Memory Address Ranges for 1-Mbyte and 2-Mbyte SIMMs

Bank	SIMM #	Physical Memory Address Ranges	
		1-Mbyte SIMMs	2-Mbyte SIMMs
1	U0304	0000000 through 01FFFFFF	0000000 through 01FFFFFF
1	U0303	0000000 through 01FFFFFF	0400000 through 05FFFFFF
2	U0301	2000000 through 21FFFFFF	2000000 through 21FFFFFF
2	U0302	2000000 through 21FFFFFF	2400000 through 25FFFFFF
3	U0402	4000000 through 41FFFFFF	4000000 through 41FFFFFF
3	U0401	4000000 through 41FFFFFF	4400000 through 45FFFFFF

TABLE 4-6 Determining the Defective DSIMM

If the physical address ends in . . .	The defective DSIMM is in . . .
0, 1, 2, 3, 8, 9, A, or B	U0304, U0301, or U0402
4, 5, 6, 7, C, D, E, or F	U0303, U0302, or U0401

Note – Both DSIMMs in a memory bank have the same physical address range. The last digit in the physical address reported determines which of the two DSIMMs in a bank caused the memory error (see TABLE 4-6).

Safety and Tools Requirements

This chapter describes standards, safety procedures, and precautions you should follow whenever you need to replace or remove assemblies or subassemblies from your system.

- Section 5.1 “Safety Requirements”
- Section 5.2 “Symbols”
- Section 5.3 “System Precautions”
- Section 5.4 “Tools Required”

5.1 Safety Requirements

For your protection, observe the following safety requirements:

- Follow all cautions, warnings, and instructions marked on the equipment.
- Ensure that the voltage and frequency rating of the power outlet to be used matches the electrical rating labels on the system.
- Use properly grounded power outlets.

To protect both yourself and the equipment, observe the safety precautions listed in TABLE 5-1.

TABLE 5-1 Safety Precautions

Item	Problem	Precaution
AC power cord	Electric shock	Unplug the AC cord from the AC wall socket before working on the power supply.
	Grounding	Leave the AC power cord plugged into the AC wall outlet when replacing drives, SIMMs, chips, or the system board. Leaving the AC power cord plugged into the wall outlet provides a grounding path for the wrist strap, which must be attached.
Wrist strap	Electrostatic Discharge (ESD)	Wear a wrist strap when handling printed circuit boards, drives, or other components such as SIMMs.
ESD mat	ESD	An approved antistatic mat provides protection from static damage when used with a wrist strap. The mat also cushions and protects small parts that are attached to printed circuit boards. Chapter 12 "Illustrated Parts Breakdown, lists the part number of the mat.
Printed circuit boards	ESD	Handle a printed circuit board by the edges only. Store a board in an antistatic bag.
Cover	System damage and overheating	Replace the cover after performing service on the system.
SBus slot filler panels	System damage and overheating	Install filler panels in all unused SBus slots. Openings on the back of system board reduces the cooling capability of the system.

5.2 Symbols

The following symbols mean:



Caution – This equipment contains lethal voltages. Accidental contact can result in serious injury or death.



Caution – Physical danger due to a non-electrical hazard or danger of irreversible damage to data or to the operating system.



Caution – Improper handling by unqualified personnel can cause serious damage to this equipment. Unqualified personnel who tamper with this equipment may be held liable for any resulting damage to the equipment.



Caution – Hot surface. Avoid contact. Surfaces are hot and may cause personal injury if touched.

5.3 System Precautions

Individuals who service this equipment must observe all safety precautions and ensure compliance with skill level requirements, certification, and all applicable local and national laws.

Procedures contained in this document must be performed by trained maintenance providers. Only people who have been trained at the Sun Microsystems® training facilities (or at Sun Microsystems affiliates) and have been certified as required by local and national laws are considered qualified.



Caution – Before you begin, carefully read each of the procedures in this manual. If you have not performed similar operations on comparable equipment, *do not attempt* to perform these procedures.

5.4 Tools Required

To remove and replace customer replaceable units (CRUs), you will need the following tools and materials:

- Small Phillips-head screwdriver
- Small flat-blade screwdriver
- Wrist strap
- Antistatic surface
- Volt Ohmmeter (VOM) for checking voltages and continuity
- Needlenose pliers
- Conductive foam to store chips
- Container for screws

You will need an antistatic surface on which to place static-sensitive parts such as boards, cards, modules, and SIMMs. The replacement procedures will let you know when you need to place a part on an antistatic surface. The following items can be used as antistatic surfaces:

- Bag that is used to wrap a Sun replacement part.
- Shipping container that is used to package a Sun replacement part.
- Inner surface of the system unit cover.
- Sun electrical static discharge (ESD) mat with Sun logo. Contact your Sun sales representative to purchase it.
- Disposable ESD mat. You can purchase it through your Sun sales representative.

Power Off and On

This chapter explains steps to perform before removing a customer replaceable unit (CRU).

- Section 6.1 “Powering Off the System”
- Section 6.2 “Powering On the System”

6.1 Powering Off the System

Before you begin any removal or replacement procedure, you must halt the system in an orderly manner. The procedure depends on whether your system is working normally or not, as described in the next sections.



Caution – When the operating system or any other standalone program has already booted, do not use the Stop-a keys to halt the system. Using the Stop-a keys to abort program execution can damage data files.

6.1.1 Powering Off When the System Is Working Normally

To halt your system when it is working normally:

- 1. Save all your work.**

Consult your software documentation for instructions on ending a work session and saving your files. If you do not save your work, you could lose it when you switch off the power.

2. Return to the operating system environment.

If you are in a windowing environment, exit from it and wait for the system prompt to appear. See the documentation supplied with your windowing system.

Note – On a SPARCclassic X terminal, just click SELECT on the Halt button in the Terminal Controls window. The system responds with an OK> prompt. You can then skip to Step 5 of this procedure.

3. Halt the operating system.

See the documentation supplied with your operating system for instructions on how to halt it.

For example, if you are using the Solaris® 2.x operating system:

1. At the system prompt, type `su` and press Return.
2. Type your superuser password and press Return.
4. **To inform other system users of your intentions, and to then halt the system use Step 3.**
5. **To halt the system immediately, continue with Step 3.**

a. Type `/usr/sbin/shutdown +5` and press Return.

The example above uses 5 minutes for a warning period to other system users. Use appropriately chosen switch settings to inform other system users of your intentions (see `shutdown(1)`). Continue with Step 4.

b. Type `/usr/sbin/init 0` and press Return.

For example, to halt the system immediately type:

```
nevada% su
Password: welcome      (Password does not appear on screen.)
nevada# /usr/sbin/init 0
```

6. After halting the operating system, wait for either the > or ok prompt.

The system displays system halt messages followed by either the > or ok prompt.

When either prompt appears, you can safely turn off the power in the proper sequence.

7. Turn off the power to the system components in this order:

1. External drive units (if you have any)
2. System unit

6.1.2 Powering Off When the System Does Not Respond Normally

To halt a system that is hung, or frozen, and unresponsive to commands:

1. If your system is on a network, wait a few minutes before proceeding.

Your system's slow response may be due to network problems or delays. Check with the person in charge of your network. If the response is not due to the network, go to the next step.

2. Press Stop-a (or Break).

If you use a Wyse® WY-50™, VT100™, or compatible terminal as the console with your SPARCstation system unit, press Break instead of Stop-a.

Note – If the system does not respond to the mouse and keyboard, pressing Stop-a will not be effective. You may have to turn the power off, wait at least 10 seconds, and turn the power on again. Then try pressing Stop-a once more.

Note – Steps 3 through 6 are not necessary for the SPARCclassic X terminal.

When the `ok` or `>` prompt appears, boot the operating system.

Enter `boot` at the `ok` prompt or `b` at the `>` prompt.

3. When you see the `login` prompt, log in to the system with your user name and password.

4. Halt the operating system.

See the documentation supplied with your operating system for instructions on how to halt it.

For example, if you are using the Solaris 2.x operating system:

1. At the system prompt, type `su` and press Return.
2. Type your superuser password and press Return.
3. Type `/usr/sbin/init 0` and press Return.

For example, to halt the system immediately type:

```
nevada% su
Password: welcome      (Password does not appear on screen.)
nevada# /usr/sbin/init 0
```

5. After halting the operating system, wait for either the > or ok prompt.

The system displays system halt messages followed by either the > or ok prompt.

When either prompt appears, you can safely turn off the power in the proper sequence.

6. Turn off the power to the system components in this order:

a. External drive units (if you have any)

b. System unit

c. Monitor

6.2 Powering On the System



Caution – Before turning on power to your system, be sure to close the system unit. It is not safe to operate your SPARCstation while the system unit is open.



Caution – These devices are equipped with a 3-wire grounded power cord. To reduce the risk of electrical shock, always plug the power cord into a properly grounded power outlet.



Caution – Always allow 10 seconds between turning off the power and turning it back on again. This pause prevents possible damage to power supply components in your system unit.

After turning off the power to replace a part, restarting the system is relatively simple:

1. Reconnect the cables.

See Section 7.5 “Reconnecting the External Cables” on page 7-7.

2. Turn on the power in this sequence:

1. External drive units (if any), starting with the unit that is furthest electrically from the system unit
2. Monitor (if you turned it off)
3. Desktop SPARCstation system unit

3. Boot the operating system.

The operating system may start to boot automatically, or you may need to enter a command at the system prompt. What you do next depends on the operating system software you are using. Consult the documentation supplied with your operating system for instructions on booting and logging in to your system.

Internal Access

This chapter describes how to access the subassemblies inside the system unit, and how to close the system unit after you have finished.

- Section 7.1 “Disconnecting the External Cables”
- Section 7.2 “Opening the System Unit”
- Section 7.3 “Attaching the Wrist Strap”
- Section 7.4 “Closing the System Unit”
- Section 7.5 “Reconnecting the External Cables”

7.1 Disconnecting the External Cables

Detach all cables connected to the rear of the system unit. Take care to remember where each cable attaches to the system unit.

Note – Do *not* disconnect the power cord from the system unit’s power receptacle. The power cord should remain connected to a grounded power outlet.

To disconnect the SCSI cable:

1. **Press in on both the finger clips of the connector that attaches the device to the system unit.**
2. **Pull the connector off.**

7.2 Opening the System Unit



Caution – Before opening the system unit, make sure the system power switch is in the Standby position. The green LED on the front of the system unit should not be lit, and the fan should not be running. When the system power switch is in the Standby position, and the AC power cord remains connected to a power outlet, hazardous AC voltage is still present in the power supply primary. Do not attempt to service the power supply under these conditions. Disconnect the AC power cord prior to handling the power supply. When servicing any other system component, the AC power cord should remain connected; it poses no safety hazard.

To open the system unit and gain access to the CRUs inside it:

1. Make sure that the system power switch is in the Standby position.

The green LED on the front of the system unit should not be lit, and the fan should not be running. Leave the AC power cord connected to both the system unit and wall outlet.

2. Position the system on the table with the rear panel facing you.

Leave enough space to lay the unit top flat on the table behind the unit bottom.

3. Remove the screw that secures the lock block to the back panel (see FIGURE 7-1).

4. Grasp the unit top at its rear corners and carefully open the system unit like a suitcase (see FIGURE 7-1).

Lay the unit top flat on the table behind the unit bottom. The unit top and bottom are still connected by the power and data cables leading from the disk drive and power supply to the main logic board.

Note – The unit top contains the power supply and disk drive, and is the heavier of the two sections.

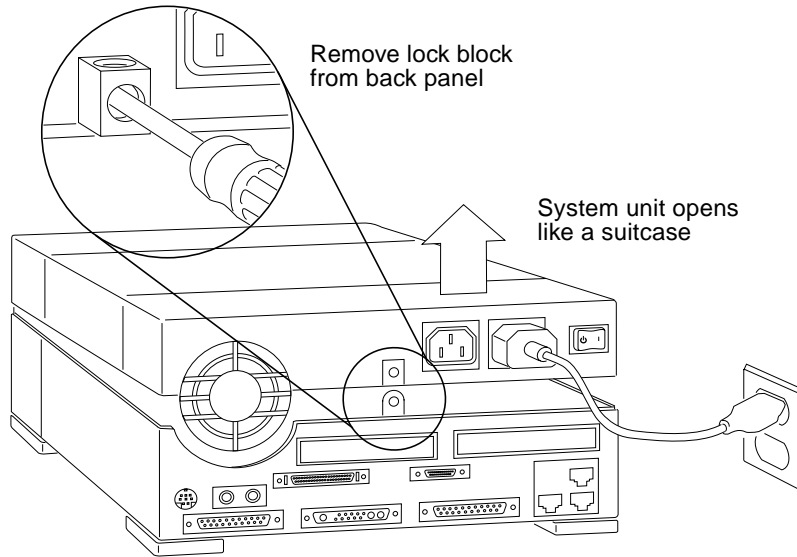

FIGURE 7-1 Opening the System Unit



Caution – When you are finished installing parts inside the system unit, be sure to close the system unit before turning on the power. It is not safe to operate the system unit while it is open. See Section 7.4 “Closing the System Unit” on page 7-4 for instructions.

7.3 Attaching the Wrist Strap

A wrist strap (or grounding strap) provides grounding for static electricity between your body and the chassis of the system unit. Electric current and voltage do not pass through the wrist strap.

Before you handle any components inside the system unit, attach the wrist strap to your wrist and to the metal casing of the power supply.



Caution – Boards and modules can be damaged by harmful electrical charges if you do not wear a wrist strap. Parts that require the use of a wrist strap are packed with one.

To attach a wrist strap:

- 1. Wrap the grounding strap twice around your wrist.**
Make sure the adhesive side is against your skin.
- 2. Attach the end with the adhesive copper strip to the metal casing of the power supply in the top of the system unit.**

Attach end to metal case of power supply.

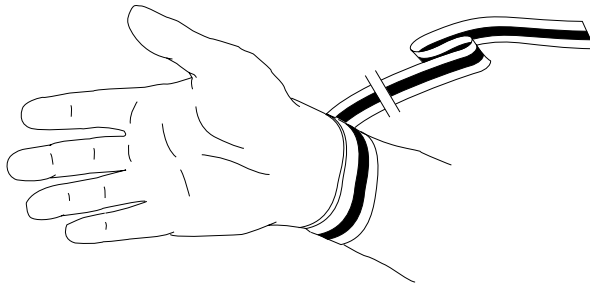

Wrap the wrist strap twice around your wrist (adhesive against your skin).

FIGURE 7-2 Attaching the Wrist Strap

To detach a wrist strap:

- 1. Unwrap the grounding strap from your wrist.**
- 2. Detach the end with the adhesive copper strip from the metal casing of the power supply in the top of the system unit.**

7.4 Closing the System Unit

To close the system unit:

- 1. Preparation.**
 - a. Check that there are no loose tools or screws in the unit.**
 - b. Check that all SBus cards and SIMMs are seated properly.**
 - c. Check that all internal cable connections are tight.**

d. Check that the power supply wiring is tucked inside the system to avoid pinching the wiring when you close the system unit.

2. Detach and remove the wrist strap.

3. Grasp the unit top near the power supply (see FIGURE 7-3).

Rotate the unit top at a 15-degree angle and rotate your hand position so that thumbs and fingers point up and the five interlock hooks can be aligned.

Note – The interlock hooks do not engage until the unit is lowered to a 45-degree angle. Continue to hold the cover with your hands.

4. Reconnect the unit top and bottom (see FIGURE 7-3).

a. Rest the front edges together to connect the interlock hooks by pushing gently toward the back of the unit.

b. As you lower the unit top, continue to push back to secure the connection. The unit top will rest slightly forward.

c. Gently push the unit top back a few millimeters until the unit top and bottom are aligned.

5. Attach the lock block.

Attach the lock block by inserting the PEM screw through the block on the outside, through the security loop on the inside, and into the power supply (see FIGURE 7-3). Tighten the screw with a screwdriver. Be careful not to overtighten the screw.

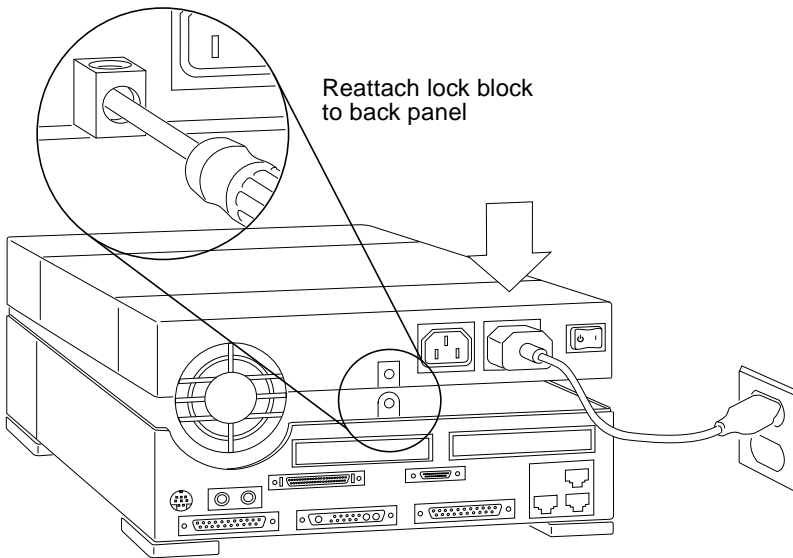
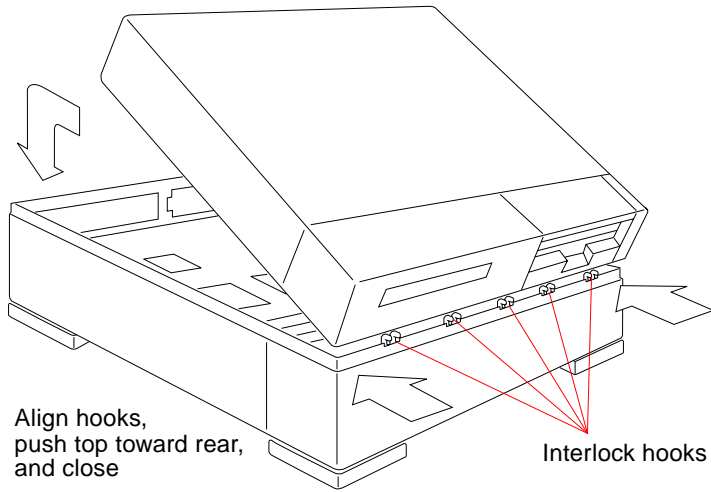

FIGURE 7-3 Closing the System Unit

7.5 Reconnecting the External Cables

Refer to FIGURE 7-4 to reconnect the system cables.

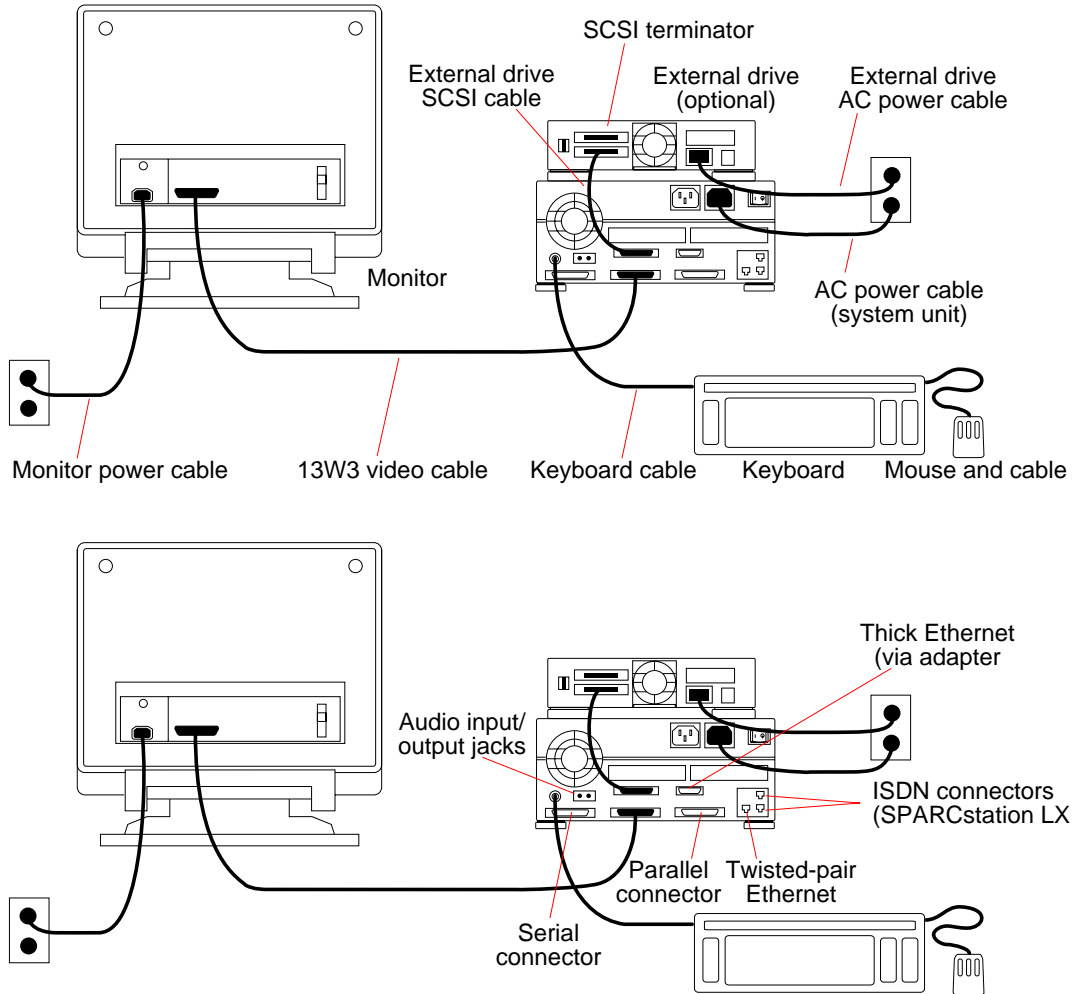

FIGURE 7-4 Reconnecting System Components

See the *Desktop SPARC Hardware Owner's Guide*, or *Using a SPARCclassic X Terminal* for complete details about cabling. To turn on power to the system, See Section 6.2 "Powering On the System" on page 6-4.

Major Subassemblies

This chapter describes how to remove and replace the system unit's major subassemblies.

- Section 8.1 "Power Supply"
- Section 8.2 "Speaker/Power LED Assembly"
- Section 8.3 "System I/O Board"

8.1 Power Supply

The power supply is a self-contained metal assembly in the system unit top just behind the disk drive mounting bracket (see FIGURE 9-12).

The power supply is held in place by four hooks in the unit top that mate with four slots in the power supply. In addition, the screw at the rear of the system unit that holds the top and bottom halves of the unit together also retains the power supply.

The power supply wiring harness branches into four separate "power cables." A 12-pin power cable connects to the main logic board in its right front corner (see FIGURE 9-13). Nearby, a 3-pin cable provides the keyboard soft power-on signal from the main logic board to the power supply. Two 4-pin power cables supply power to the hard disk drive and diskette drive (if present).

The power supply is auto-sensing and will operate with input voltage of 100-120 Vac or 200-240 Vac without adjustment. If the power supply fails to operate, replace it.

FIGURE 8-1 shows how to remove and replace the power supply.

8.1.1 Removing the Power Supply

To remove the power supply:

1. Prepare to work on the system as described in Chapter 7 “Internal Access.

Halt the system and verify that the power LED is not lit and that the fan is not running. Then open the system unit and attach a wrist strap as described in Section 7.3 “Attaching the Wrist Strap” on page 7-3.

2. Make sure that the system unit’s power is in the Standby position.

Make sure that the green LED at the front of the chassis is not lit and that the fan in the power supply is not running.

3. Remove the disk drive mounting bracket.

The disk drive mounting bracket must be removed before the power supply can be lifted out of the system unit. Follow the directions in Section 9.2.1 “Removing the Disk Drive Mounting Bracket” on page 9-16 for removing the disk drive mounting bracket (ignore step 1 and the Caution that follows it).

4. Make sure that you disconnected the power supply wiring harness from the diskette drive, hard disk drive, and main logic board.

5. Disconnect the system unit AC power cord and detach the wrist strap from the power supply.

For this procedure, the power cord must *not be* connected between the system unit and the AC wall outlet.



Caution – Make sure that the system unit is unplugged from the AC power outlet and that the power switch is in the Standby position before you remove, replace, or install the power supply. Failure to take this precaution may result in severe electrical shock.

6. Remove the power supply (see FIGURE 8-1).

Grasp the power supply firmly and slide it about 0.25 inch toward the front of the unit to disengage it from the four hooks in the bottom of the system unit. Lift the power supply straight up and out. If the power supply does not lift easily, be sure that it has cleared the hooks.

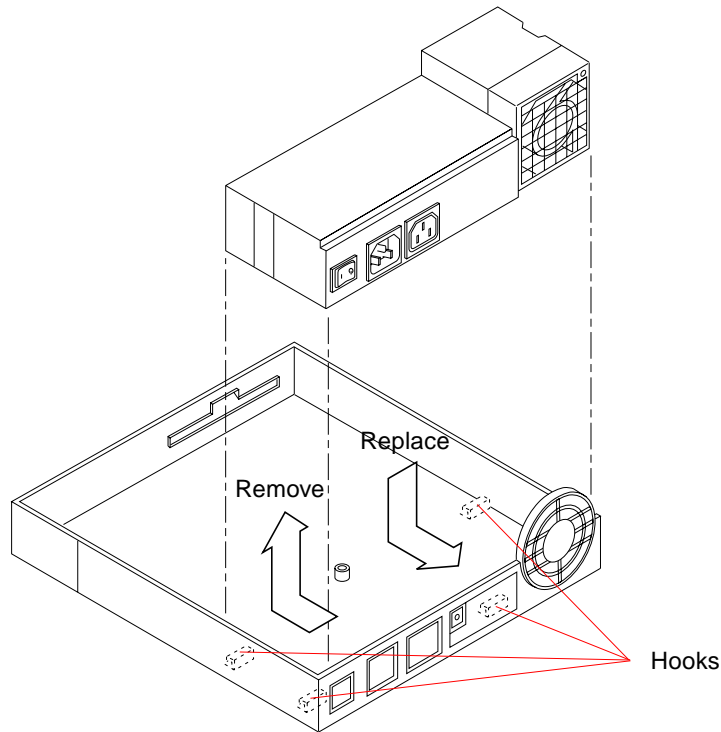

FIGURE 8-1 Removing and Replacing the Power Supply

8.1.2 Replacing the Power Supply

To install a new power supply:

- 1. Remove the faulty power supply as described in the previous section.**
- 2. Install the new power supply.**
 1. Align the holes in the bottom of the power supply with the hooks in the system unit top (see FIGURE 8-1).
 2. Lower the power supply into the unit top as shown.
 3. Properly position the power supply by pushing it firmly toward the rear of the unit (about 0.25 inch) until it engages with the hooks.
- 3. Reattach the wrist strap to the metal casing of the new power supply.**

4. Connect the AC power cord between the system unit and an AC wall outlet to provide the ground path for the wrist strap.

5. Reinstall the disk drive mounting bracket.

Reinstall the disk drive mounting bracket in front of the power supply. For detailed instructions, see Section 9.2.2 “Replacing the Disk Drive Mounting Bracket” on page 9-19.

6. Be sure to reconnect the power supply wiring harness to the diskette drive, hard disk drive, and main logic board.

Connect the 12-pin and 3-pin connectors from the wiring harness to the power connector and keyboard soft power-on connector on the main logic board. Connect the 4-pin connectors from the harness to the hard disk drive and diskette drive (if present). Each connector is keyed to fit only one way.

7. Refer to Chapter 7 “Internal Access to perform the following procedures:

- Detaching the wrist strap
- Closing the system unit
- Reconnecting system components

8. Refer to Chapter 6 “Power Off and On to turn the power on.

After turning the power back on, check for proper operation of the system unit and the newly installed power supply. If the newly installed power supply still does not work properly, a problem may exist in the system unit, such as a blown component or a short circuit.

8.2 Speaker/Power LED Assembly

This section describes the removal and replacement procedures for the speaker/power LED assembly. This assembly is mounted on the right-hand side of the system unit bottom (see FIGURE 8-8).

8.2.1 Removing the Speaker/Power LED Assembly

To remove the speaker/power LED assembly:

1. Prepare to work on the system as described in Chapter 6 “Power Off and On, and in Chapter 7 “Internal Access.

Halt the system and verify that the power LED is not lit and that the fan is not running. Then open the system unit and attach a wrist strap as described in Section 7.3 “Attaching the Wrist Strap” on page 7-3.



Caution – The AC power cord should remain attached between the system unit and an AC wall outlet. This connection provides the ground path necessary to protect internal system components from harmful static discharges. Inside the system unit, be sure the power supply wiring harness is connected to the main logic board to complete the ground.



Caution – Verify that the system power switch is in the Standby position. The green LED at the front of the system unit should not be lit and the fan should not be running. When the system power switch is in the Standby position, and the AC power cord remains connected to a power outlet, hazardous AC voltage is still present in the power supply primary. Do not attempt to service the power supply under these conditions. Disconnect the AC power cord prior to handling the power supply. When servicing any other system component, the AC power cord should remain connected and poses no safety hazard.

2. Disconnect the speaker/LED cable from its connector on the main logic board.

For the connector location, see Chapter 11 “Main Logic Board and Component Replacement.”

3. Squeeze the speaker assembly where indicated in FIGURE 8-2 and slide it up and out of the system unit.



Caution – Do not touch or press on the speaker cone. You may damage the speaker or the sound quality.

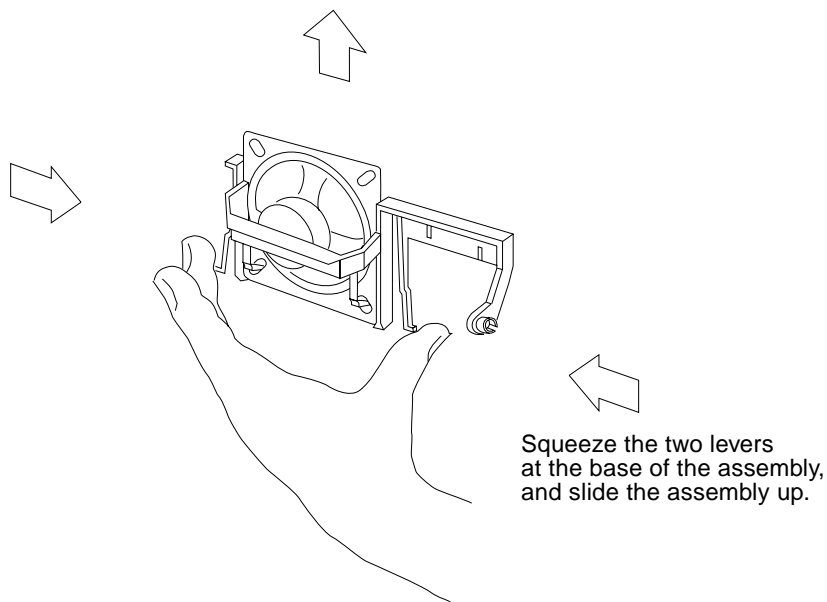

FIGURE 8-2 Removing and Replacing the Speaker/Power LED Assembly

8.2.2 Replacing the Speaker/Power LED Assembly

To replace the speaker/power LED assembly:

1. **Remove the faulty speaker/power LED assembly as described in the previous section.**
2. **Squeeze the replacement speaker assembly where indicated in FIGURE 8-2 and slide it down into its channel guides until it snaps into place.**



Caution – Do not touch or press on the speaker cone. You may damage the speaker or the sound quality.

3. **Reconnect the speaker/LED cable to its connector on the main logic board.**
The connector is keyed to fit only one way. For the connector location, see Chapter 11 “Main Logic Board and Component Replacement.”
4. **Refer to Chapter 7 “Internal Access to perform the following procedures:**
 - Detaching the wrist strap
 - Closing the system unit

- Reconnecting system components

5. Refer to Chapter 6 “Power Off and On to turn the power on.

8.3 System I/O Board

The system I/O board is located in the bottom half of the system unit (see FIGURE 8-3). It provides all of the system’s I/O connectors through cutouts in the unit’s rear panel. The main logic board plugs into the system I/O board.



Caution – Printed circuit boards are made of delicate electronic components that are extremely sensitive to static electricity. Ordinary amounts of static from your clothes or work environment can destroy the boards. Handle boards only by the non-conducting edges. Do not touch the components themselves or any metal parts. Always wear a grounding (wrist) strap when handling the boards. Attach the wrist strap to the metal casing of the power supply at the rear of the unit top.

8.3.1 Removing the System I/O Board

To remove the system I/O board:

1. Prepare to work on the system as described in Chapter 6 “Power Off and On, and in Chapter 7 “Internal Access.

Halt the system and verify that the power LED is not lit and that the fan is not running. Then open the system unit, detach all peripherals, and attach a wrist strap as described in Section 7.3 “Attaching the Wrist Strap” on page 7-3.



Caution – The AC power cord should remain attached between the system unit and an AC wall outlet. This connection provides the ground path necessary to protect internal system components from harmful static discharges. Inside the system unit, be sure the power supply wiring harness is connected to the main logic board to complete the ground.



Caution – Verify that the system power switch is in the Standby position. The green LED at the front of the system unit should not be lit and the fan should not be running.



Caution – When the system power switch is in the Standb position, and the AC power cord remains connected to a power outlet, hazardous AC voltage is still present in the power supply primary. Do not attempt to service the power supply under these conditions. Disconnect the AC power cord prior to handling the power supply. When servicing any other system component, the AC power cord should remain connected and poses no safety hazard.

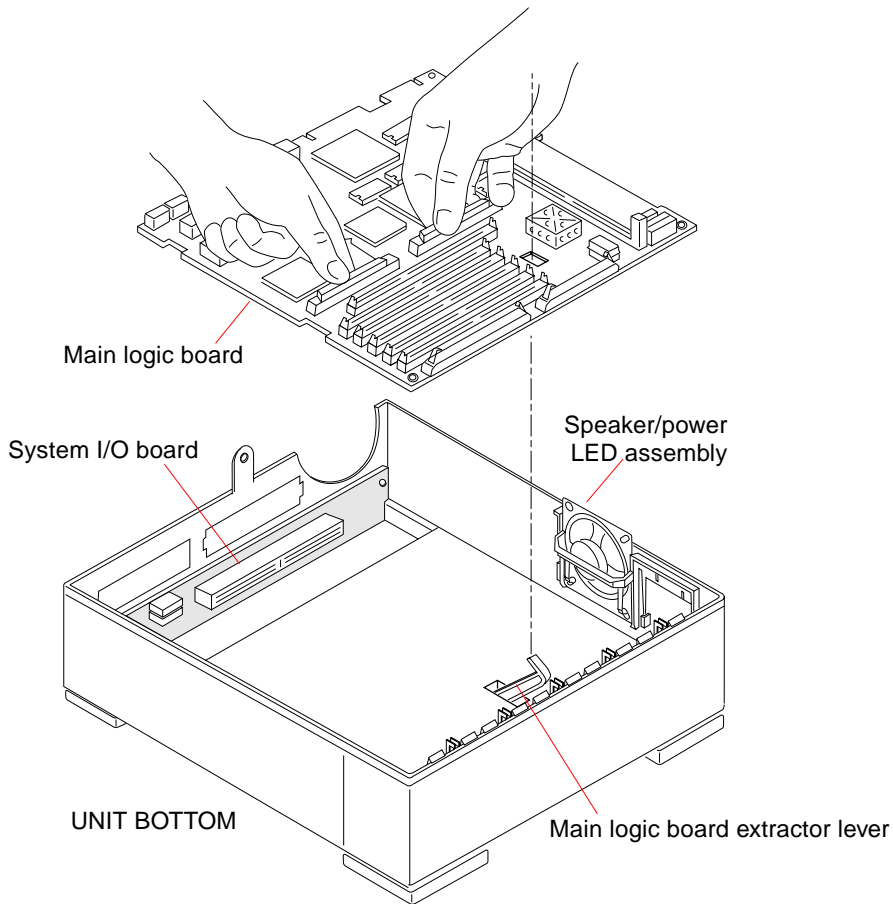

FIGURE 8-3 System I/O Board and Unit Bottom

- 2. Place an antistatic mat, shiny side down, next to the system unit.**
- 3. Remove any SBus cards installed in the system unit.**

See Section 11.1 “SBus Cards” on page 11-1 for removal procedures.

4. Disconnect all cables attached to the main logic board.

For connector locations, choose the appropriate board illustration in Chapter 11 “Main Logic Board and Component Replacement.

1. Disconnect the 12-pin power supply cable from its mating connector by squeezing the clip at the end of the cable and pulling straight up.
2. Disconnect the keyboard soft power-on cable from its connector next to the 12-pin power supply connector.
3. Disconnect the LED/speaker cable from its mating connector on the main logic board.
4. Disconnect the diskette drive and hard disk drive data cables from their connectors at the front of the main logic board.

5. Remove the main logic board.

1. Pull the main logic board extractor lever toward the front of the system unit to disconnect the main logic board from the system I/O board (see FIGURE 8-4).
2. Raise the speaker assembly to allow removal of the main logic board (see FIGURE 8-5).
3. Grasp the board by the SBus connectors with both hands. Tilt the board slightly to avoid the speaker assembly and lift it up and out of the system unit (see FIGURE 8-6). Avoid handling any of the delicate electronic components or touching any of the circuit board traces.
4. Place the main logic board on an antistatic mat.

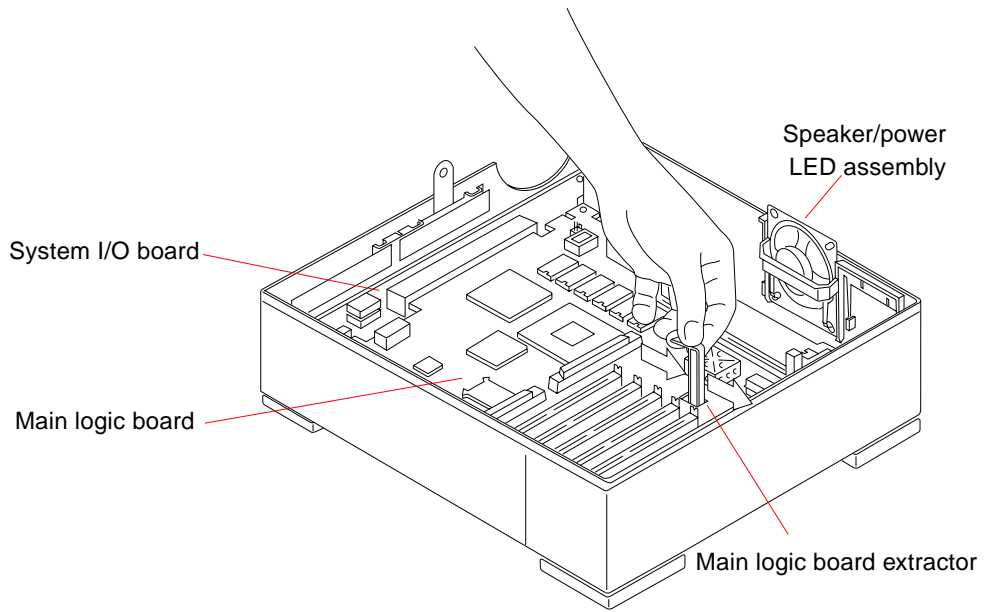

FIGURE 8-4 Extracting the Main Logic Board

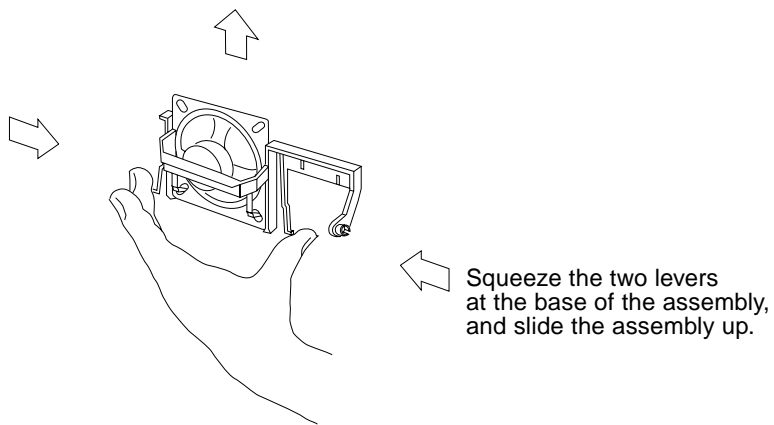

FIGURE 8-5 Raising the Speaker/LED Assembly

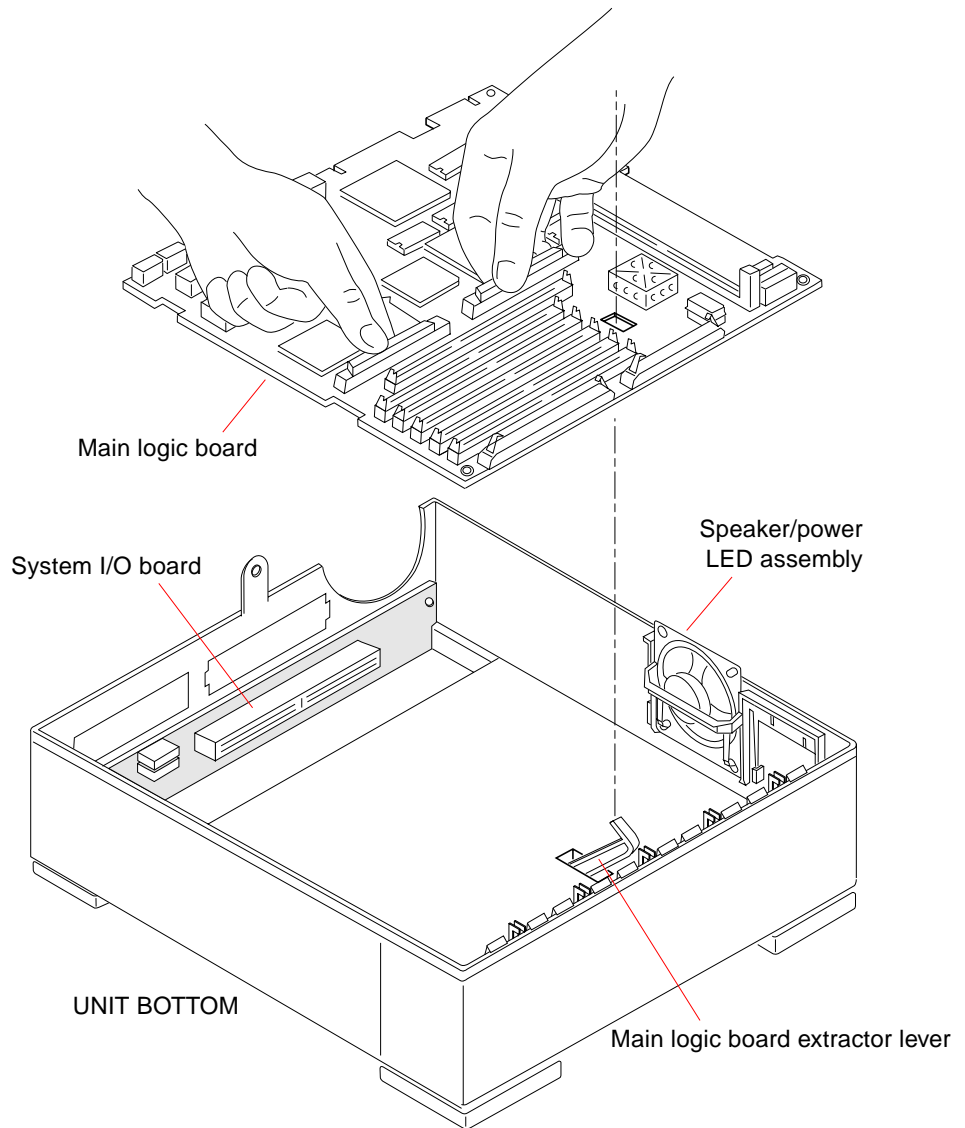

FIGURE 8-6 Removing and Replacing the Main Logic Board

6. Remove the system I/O board.

1. On the SPARCclassic X terminal, pull the plastic connector covers off the inactive ports to gain access to the screws.

2. Use a small flat-blade screwdriver to remove the 10 screws that secure the system I/O board to the system unit chassis (see FIGURE 8-7). Take care to remember where each screw belongs.
3. Pull the system I/O board away from the back panel to remove it.

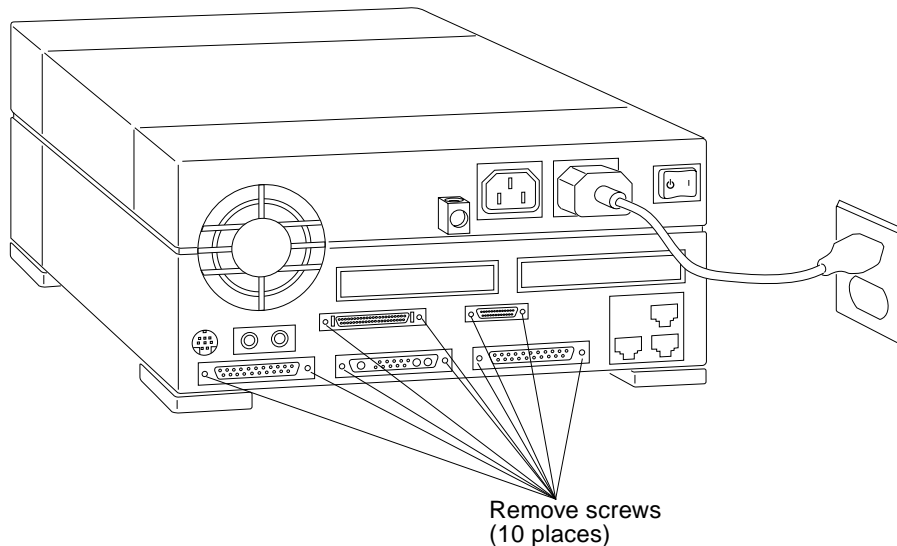

FIGURE 8-7 Removing the System I/O Board

8.3.2 Replacing the System I/O Board

To replace the system I/O board:

1. **Replace the system I/O board.**
 - a. **Position the system I/O board so that its connectors protrude through their respective openings in the system unit chassis.**
 - b. **Align the screw holes in the chassis with the holes in the system I/O board and secure the board with the 10 screws provided (see FIGURE 8-7). (Replace the plastic connector covers, if necessary.)**
2. **Reinstall the main logic board.**
 - a. **Grasp the board by the SBus connectors with both hands. Insert the main logic board extractor lever through the rectangular cutout in the main logic board (see FIGURE 8-6). Avoid handling any of the delicate electronic components or touching any of the circuit board traces.**

- b. Tilt the board to avoid the speaker assembly and lower it onto the floor of the system unit.**
 - c. Align the board's edge connector with its mating connector on the system I/O board.**
 - d. Push the main logic board extractor lever toward the rear of the system unit to plug the main logic board into the system I/O board (see FIGURE 8-8).**
 - e. Lower the speaker assembly back to its original position.**
- 3. Reconnect all cables that attach to the main logic board.**

Each connector is keyed to fit only one way. For connector locations, see Chapter 11 "Main Logic Board and Component Replacement."

- a. Connect the 12-pin connector from the power supply harness to its mating connector on the main logic board.**
- b. Connect the 3-pin connector from the power supply harness to the keyboard soft power-on connector on the main logic board.**
- c. Connect the LED/speaker cable to its mating connector on the main logic board.**
- d. Connect the diskette drive and hard disk drive data cables to their connectors at the front of the main logic board.**

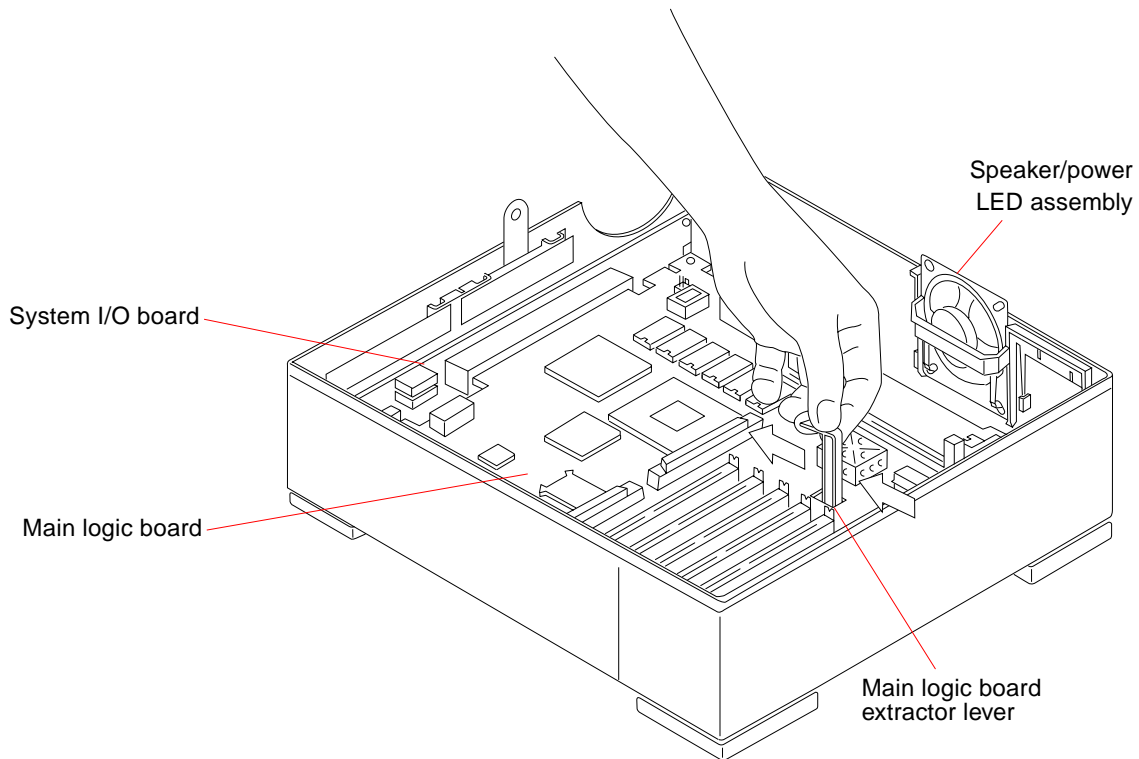

FIGURE 8-8 Plugging in the Main Logic Board

4. Reinstall any SBus cards (if applicable).

See Section 11.1.2 “Replacing SBus Cards” on page 11-4 for installation details.

5. Refer to Chapter 7 “Internal Access” to perform the following procedures:

- Detaching the wrist strap
- Closing the system unit
- Reconnecting system components

6. Refer to Chapter 6 “Power Off and On to turn the power on.

Storage Devices

This chapter includes information about how to replace the system storage drives.

- Section 9.1 “Hard Disk Drive”
- Section 9.2 “Disk Drive Bracket”
- Section 9.3 “Diskette Drive”

9.1 Hard Disk Drive

One 3.5-inch hard disk drive can be installed in the top section of the system chassis. A 50-pin SCSI data cable and a 4-pin power cable connect to the rear of the drive. The hard disk drive is mounted beside the optional diskette drive and can be accessed without removing the disk drive mounting bracket.



Caution – The hard disk drive and diskette drive contain electronic components that are extremely sensitive to static electricity. Ordinary amounts of static from your clothes or work environment can destroy the components. Do not touch the components themselves or any metal parts. Always wear a grounding strap when handling these drives. Attach the strap to your wrist and to the metal casing of the power supply.



Caution – The AC power cord should remain attached between the system unit and an AC wall outlet. This connection provides the ground path necessary to protect internal system components from harmful static discharges. Inside the system unit, be sure the power supply wiring harness is connected to the main logic board to complete the ground.



Caution – Verify that the system power switch is in the Standby position. The green LED at the front of the system unit should not be lit and the fan should not be running. When the system power switch is in the Standby position, and the AC power cord remains connected to a power outlet, hazardous AC voltage is still present in the power supply primary. Do not attempt to service the power supply under these conditions. Disconnect the AC power cord prior to handling the power supply. When servicing any other system component, the AC power cord should remain connected and poses no safety hazard.

9.1.1 Removing a Hard Disk Drive

To remove a hard disk drive from the system unit:

- 1. Prepare to work on the system as described in Chapter 6 “Power Off and On, and in Chapter 7 “Internal Access.**

Halt the system and verify that the power LED is not lit and the fan is not running. Then open the system unit and attach a wrist strap as described in Section 7.3 “Attaching the Wrist Strap” on page 7-3.

- 2. Place an antistatic mat, shiny side up, next to the system unit.**
- 3. Disconnect the hard drive data cable from its connector on the main logic board.**
See FIGURE 9-1 for the cable location.
- 4. Disconnect the hard drive power cable from the hard drive.**
See FIGURE 9-1 for the cable location.
- 5. Disconnect the data cable from its connector on the hard drive.**
Set the data cable aside for installation on the replacement drive.
- 6. Remove the four screws securing the hard drive to the drive bracket.**
- 7. Lift the hard drive straight up to remove it from the system unit.**

Place the drive on the antistatic mat. This completes the hard disk drive removal process.

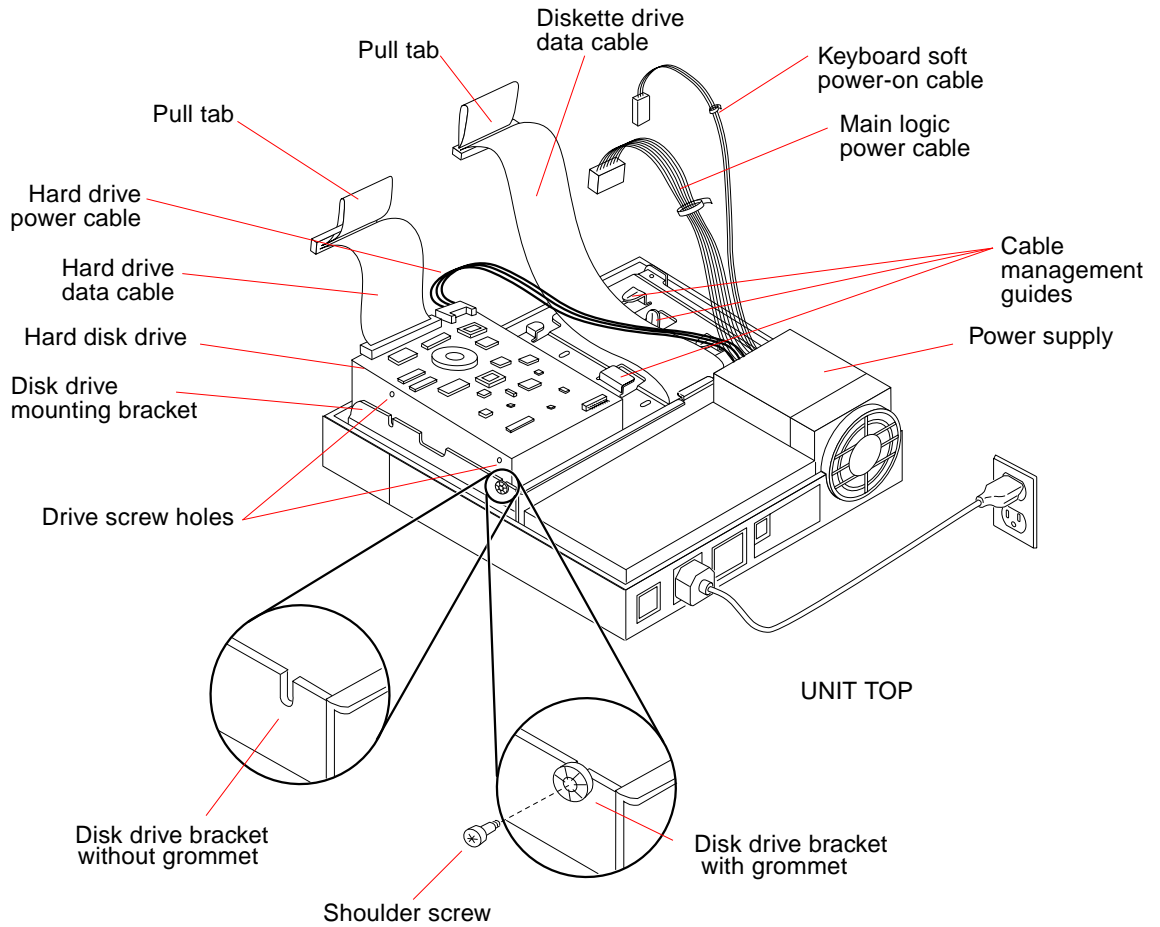

FIGURE 9-1 Hard Disk Drive in the Disk Drive Bracket

9.1.2 Preparing a Hard Drive for Installation

To prepare a hard drive for installation, you must first verify that the SCSI ID jumpers on the drive controller board are set correctly. After you are satisfied that the SCSI ID jumpers are correct, follow the directions later in the chapter for installing the hard drive.

9.1.2.1 Verifying the Jumper Settings

The SCSI ID jumpers must be set to SCSI address 3. This is the factory default setting, but you should verify the jumper settings.

The location of the SCSI ID jumpers depends on the type of drive shipped with your system. FIGURE 9-2 through FIGURE 9-7 show the jumper locations and settings for the various types of replacement drives. Note that only one of these illustrations applies to your hard drive.

To verify the jumper settings on the hard drive:

- 1. Remove the replacement drive from its protective packaging and set it with the component side up on the antistatic mat.**
You now have access to the drive controller board.
- 2. Inspect the jumper settings.**
 - a. Determine which illustration among FIGURE 9-2 through FIGURE 9-7 matches your drive.**
 - b. Compare the jumper settings in the figure to the settings on your drive.**
 - c. If the settings are not the same, change them to match the settings in the figure.**

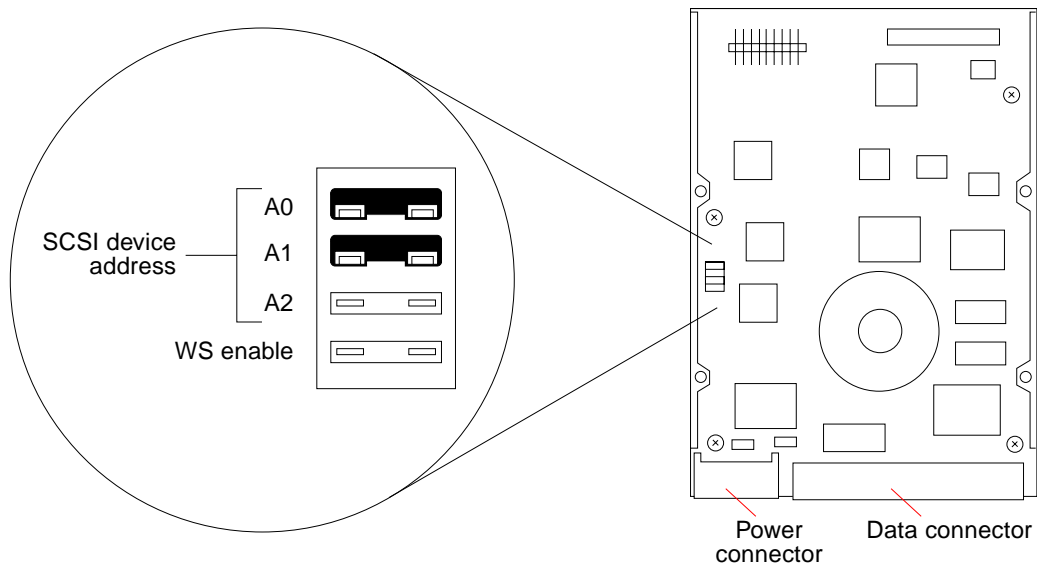

FIGURE 9-2 Jumper Settings for 207-Mbyte Drive With Jumpers on the Left-Hand Side

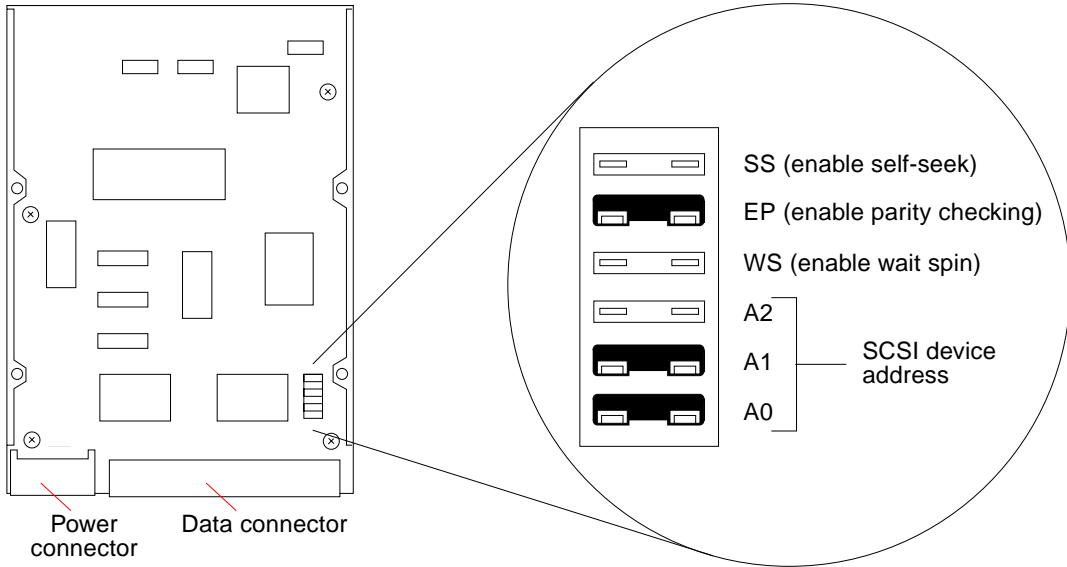

FIGURE 9-3 Jumper Settings for 207-Mbyte Drive With Jumpers on the Right-Hand Side

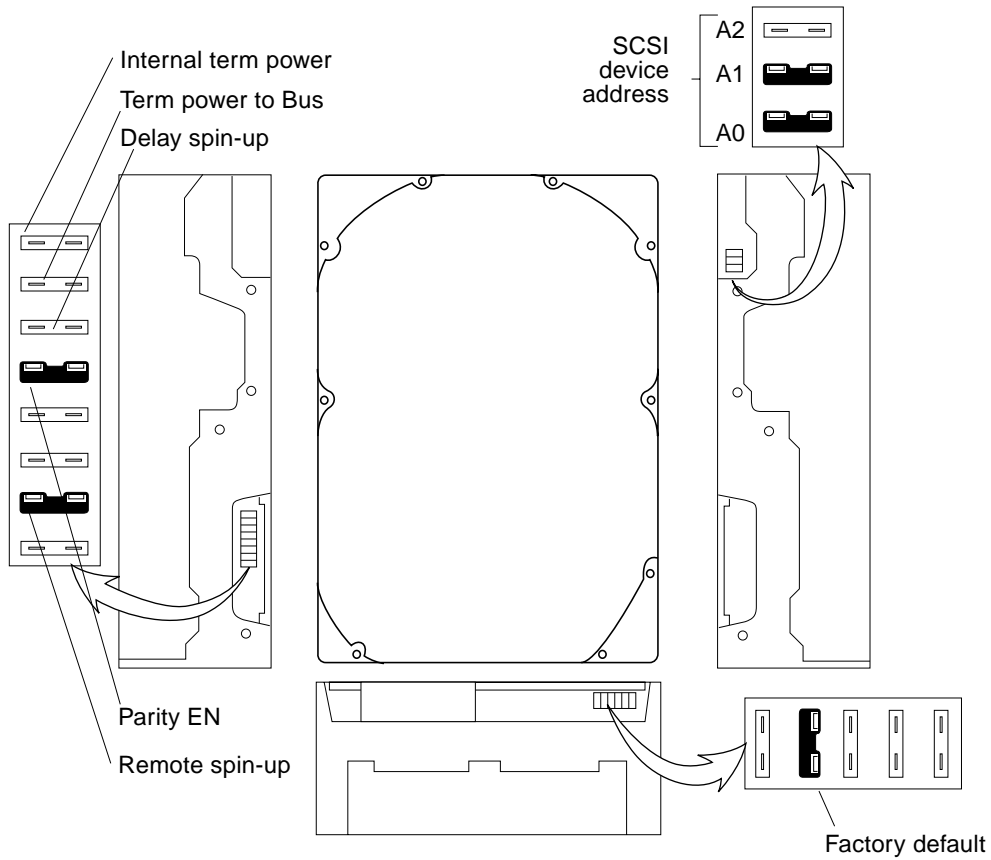

FIGURE 9-4 Jumper Settings for 424-Mbyte Drive

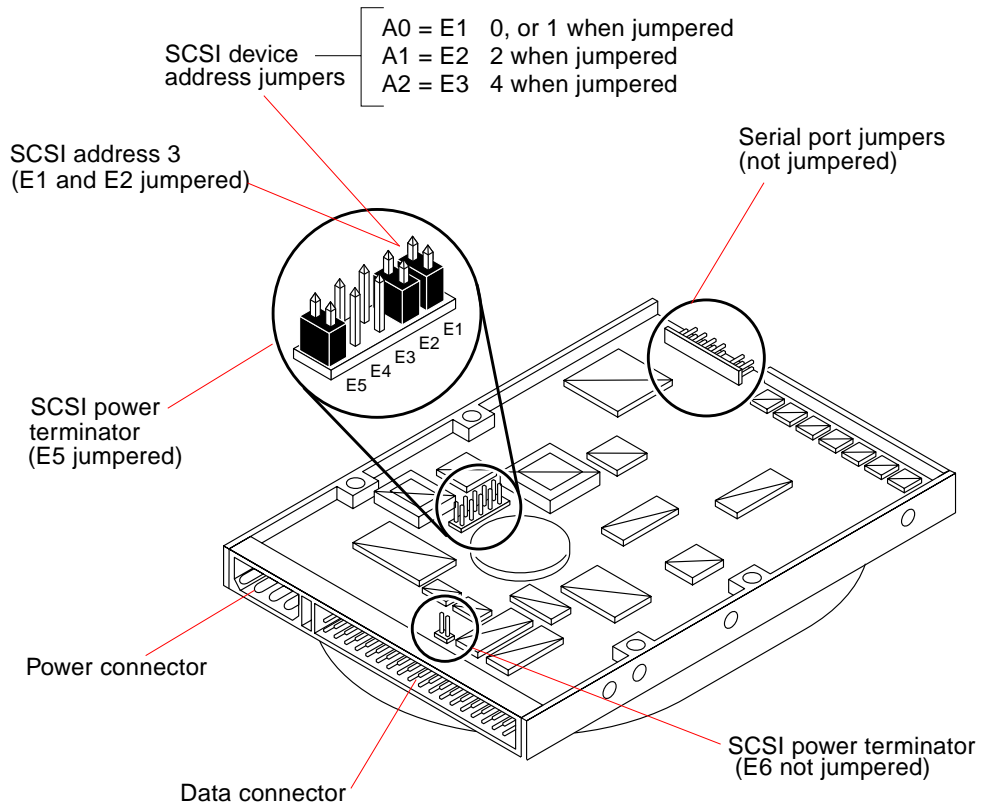

FIGURE 9-5 Jumper Settings for Conner 535-Mbyte Drive

TABLE 9-1 describes the 535-megabyte Conner drive's factory jumper settings.

TABLE 9-1 535-Mbyte Conner Drive Configuration Jumpers

Pin Pair	Description	Factory Set
E1	SCSI ID address	Yes
E2	SCSI ID address	Yes
E3	SCSI ID address	No

TABLE 9-1 535-Mbyte Conner Drive Configuration Jumpers (Continued)

Pin Pair	Description	Factory Set
E4	Wait spin disabled	No
E5	Disk power termination	Yes
E6	SCSI bus power termination	No

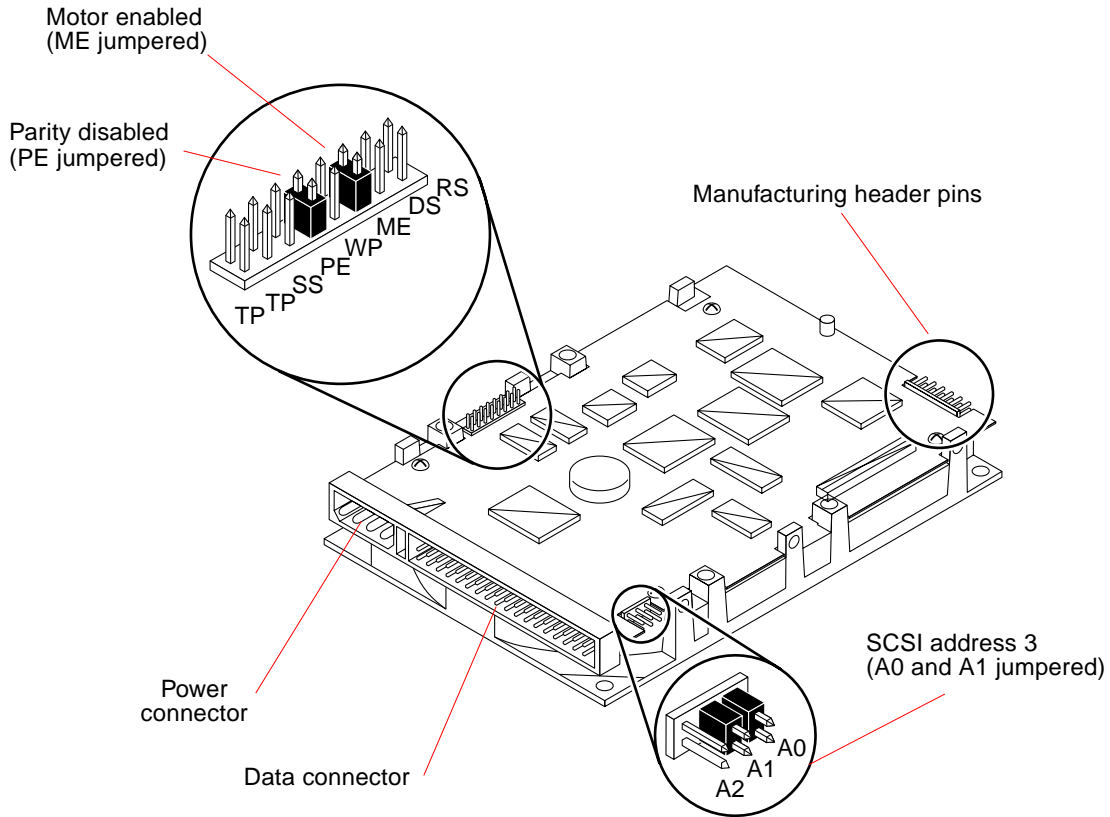

FIGURE 9-6 Jumper Settings for Seagate 535-Mbyte Drive

TABLE 9-2 describes the 535-megabyte Seagate drive's factory jumper settings.

TABLE 9-2 535-Mbyte Seagate Drive Configuration Jumpers

Abbreviation	Description	Factory Set
RS	Reserved	No
DS	Motor start delay	No
ME	Motor start is enabled at unit's start command	Yes
WP	Write protect disabled	No
PE	Parity disabled	Yes
SS	Reserved	No
TP	Drive does not supply power termination to itself	No
TP	Drive does not supply power termination to the SCSI bus	No

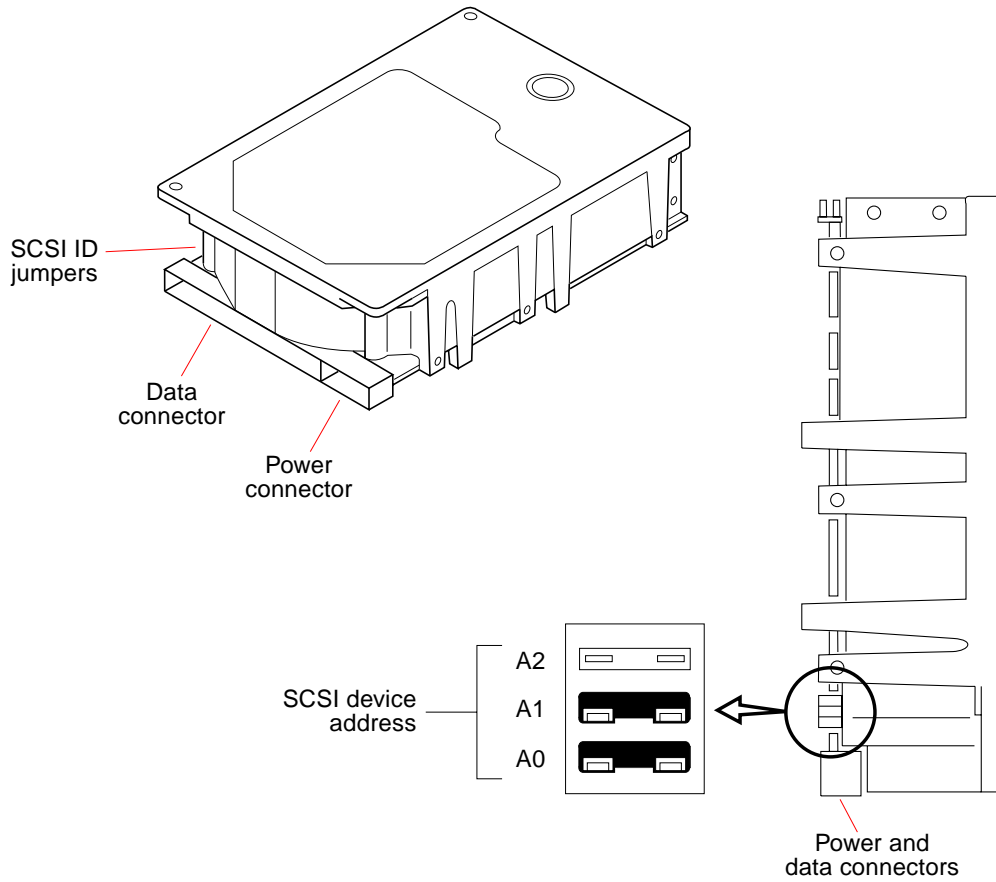

FIGURE 9-7 Jumper Settings for 1.0-Gbyte Drive (Part 370-1546)

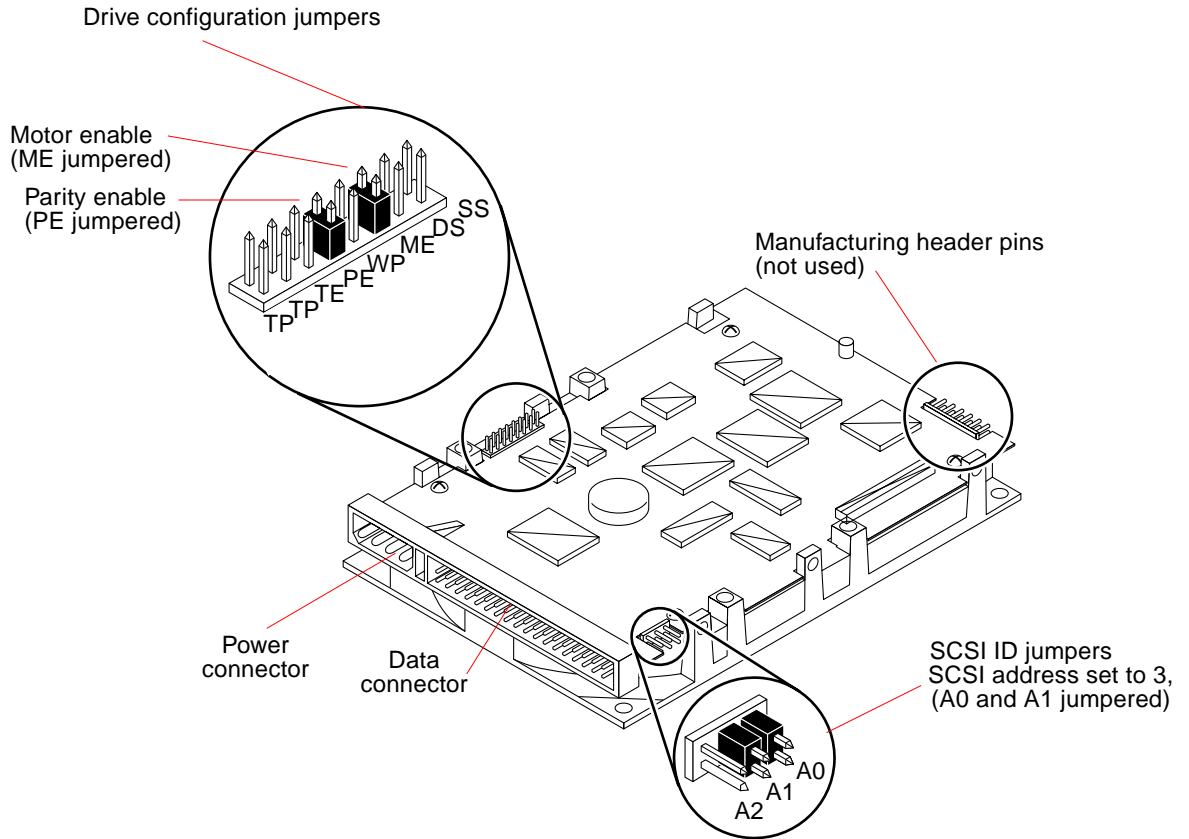

FIGURE 9-8 Jumper Settings for Seagate 1.0-Gbyte Drive

TABLE 9-3 describes the 1.0-gigabyte Seagate drive's factory jumper settings.

TABLE 9-3 1.0-Gbyte Seagate Drive Configuration Jumpers

Abbreviation	Description	Factory Set
SS	(Reserved)	No
DS	Delayed start	No
ME	Motor enable	Yes
WP	Write protect	No
PE	Parity enable	Yes

TABLE 9-3 1.0-Gbyte Seagate Drive Configuration Jumpers (Continued)

Abbreviation	Description	Factory Set
TE	Termination enable	No
TP	Termination power from drive	No
TP	Termination power to SCSI bus	No

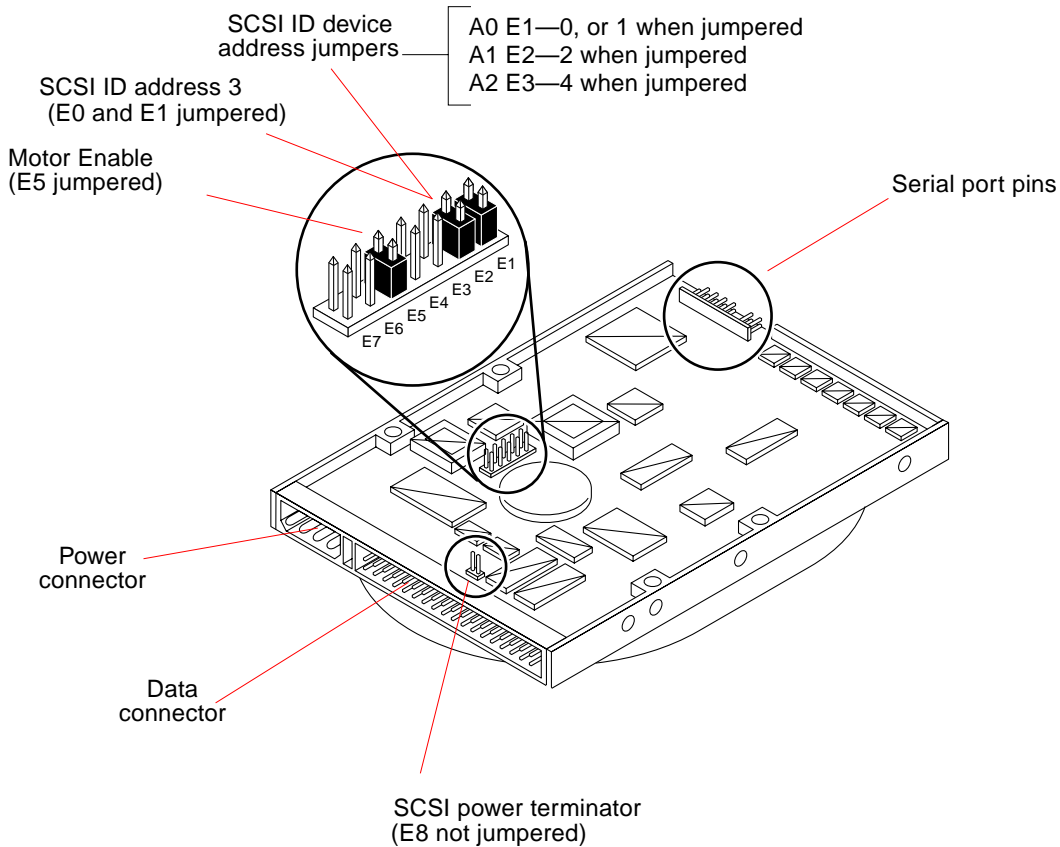

FIGURE 9-9 Jumper Settings for Connor 1.0-Gbyte Drive

TABLE 9-4 describes the 1.0-gigabyte Connor drive's factory jumper settings.

TABLE 9-4 1.0-Gbyte Conner Drive Configuration Jumpers

Pin Pair	Description	Factory Set
E1	SCSI ID address	Yes
E2	SCSI ID address	Yes
E3	SCSI ID address	No
E4	(Reserved)	No
E5	Motor enable	Yes
E6	Delay spin	No
E7	Disable parity	No
E8	SCSI bus power termination	No

9.1.3 Installing a Hard Disk Drive

To install a hard disk:

1. **Refer to** FIGURE 9-10.
2. **Determine which type of disk drive mounting bracket you have.**
 - a. *If the disk drive bracket does not have grommets, continue with Step 3.*
 - b. *If the disk drive bracket has grommets, skip Step 3 and move on to Step 4.*
3. **For a drive bracket without grommets, partially insert the standard mounting screws into the drive screw holes.**

Use the holes that are closest to the corners of the drive. *Now skip ahead to Step 5.*
4. **If the drive bracket has grommets, insert a shoulder screw into each grommet, leaving enough clearance for the drive to be lowered into the bracket.**
5. **Lower the hard drive into the bracket and tighten the four screws.**

Note – The drive may not sit perfectly flat until it is completely fastened.

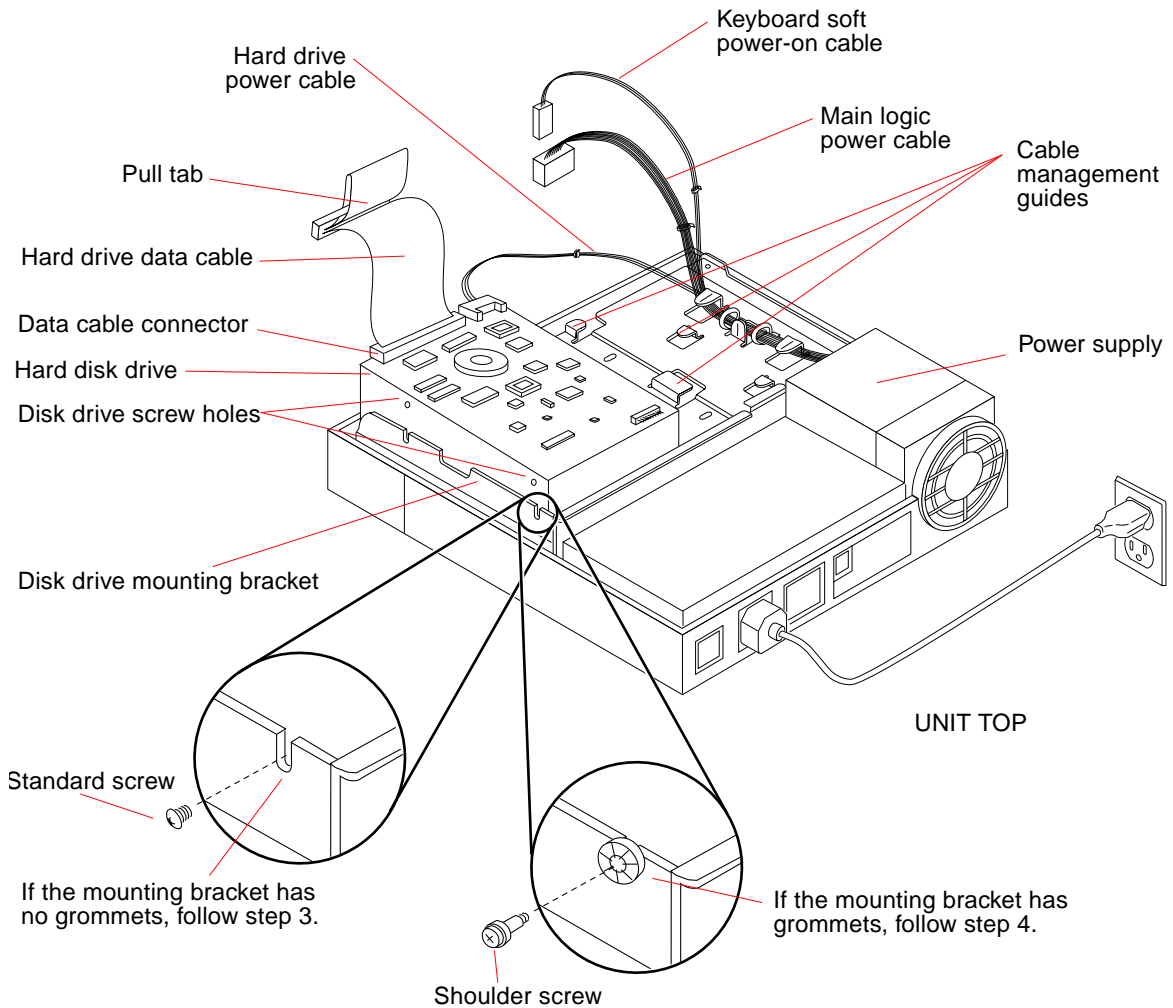

FIGURE 9-10 Installing a Hard Disk Drive

6. Attach the hard drive data cable to the data cable connector on the disk drive.

The location of the data connector on the disk drive is shown in FIGURE 9-10. The data cable connector is keyed to fit only one way.



Caution – Carefully align the connector pins with the socket to avoid damaging the pins. Do not force the connection.

7. Locate the disk drive power cable coming from the power supply and connect it to the disk drive.

The disk drive power cable has a small 4-pin connector. The power connector on the hard drive is located next to the data connector, and is shown in FIGURE 9-1. Make the connection so that the beveled edge of the connector is facing down.

8. Attach the disk drive data cable to the disk drive data connector on the main logic board.

See FIGURE 9-11 for the connector's location. The connector is keyed to fit only one way.

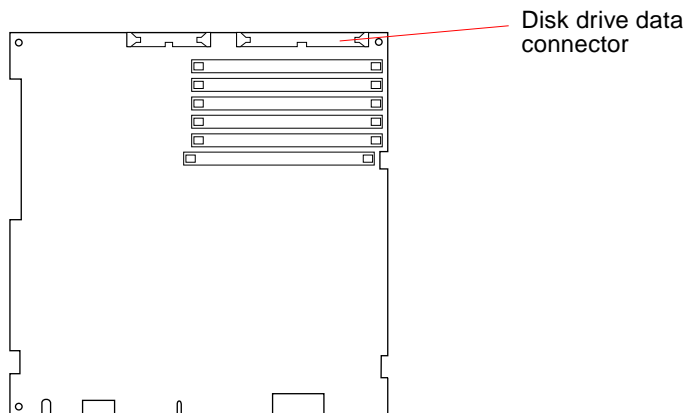

FIGURE 9-11 Main Logic Board

This completes the procedure for installing the disk drive.

9.2 Disk Drive Bracket

The disk drive bracket resides in the top part of the system unit in front of the power supply (see FIGURE 9-13). It houses both the diskette drive and the hard disk drive. The hard drive may be removed independently of the disk drive mounting bracket, but you must remove the disk drive bracket before removing the diskette drive or power supply. Refer to FIGURE 9-12 through FIGURE 9-15 for the location of the disk drive mounting bracket and the captive screw that secures it to the system.

9.2.1 Removing the Disk Drive Mounting Bracket

To remove the disk drive mounting bracket:

1. **Prepare to work on the system as described in Chapter 6 “Power Off and On,” and in Chapter 7 “Internal Access.**

Halt the system and verify that the power LED is not lit and the fan is not running. Then open the system unit and attach a wrist strap as described in Section 7.3 “Attaching the Wrist Strap” on page 7-3.



Caution – The AC power cord should remain attached between the system unit and an AC wall outlet. This connection provides the ground path necessary to protect internal system components from harmful static discharges. Inside the system unit, be sure the power supply wiring harness is connected to the main logic board to complete the ground.



Caution – Verify that the system power switch is in the Standby position. The green LED at the front of the system unit should not be lit and the fan should not be running. When the system power switch is in the Standby position, and the AC power cord remains connected to a power outlet, hazardous AC voltage is still present in the power supply primary. Do not attempt to service the power supply under these conditions. Disconnect the AC power cord prior to handling the power supply. When servicing any other system component, the AC power cord should remain connected and poses no safety hazard.

2. **Place an antistatic mat, shiny side up, next to the system unit.**
3. **Disconnect cables.**
 - a. **Free the power and diskette drive data cables (if present) from the cable management guides located above the diskette drive (see FIGURE 9-12).**
 - b. **Disconnect the power cable attached to the hard disk drive (see FIGURE 9-12).**
 - c. **Disconnect the main logic power cable and the keyboard soft power-on cable from the main logic board (see FIGURE 9-12).**
 - d. **Disconnect the diskette drive data cable (if present) and the hard disk data cable from their connectors on the main logic board (see FIGURE 9-12).**

Note – When pulling up the data cable’s pull tab, brace the main logic board near the socket to minimize board flex.

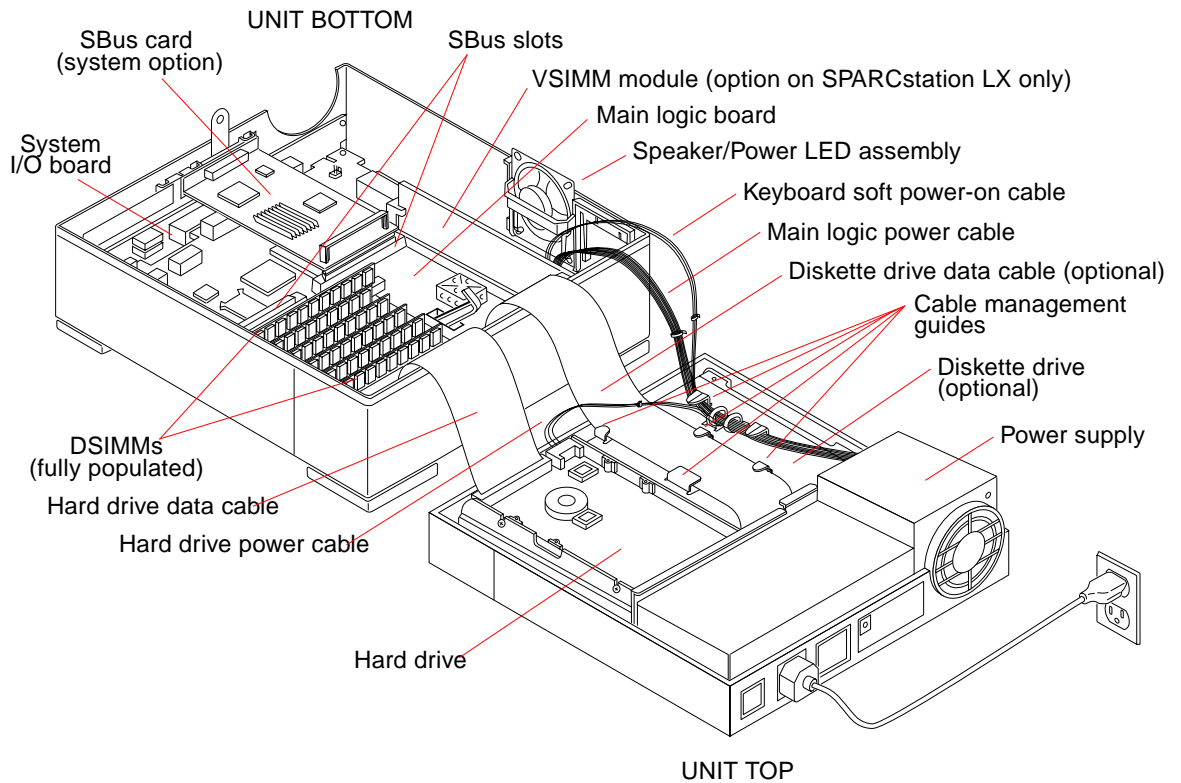

FIGURE 9-12 Open View of System Unit

4. Loosen the captive Phillips-head screw that secures the disk drive mounting bracket to the system chassis.

See FIGURE 9-13 and FIGURE 9-14 for the screw's location.

Lift up the bracket as you loosen the screw until the bracket disengages from the unit top.

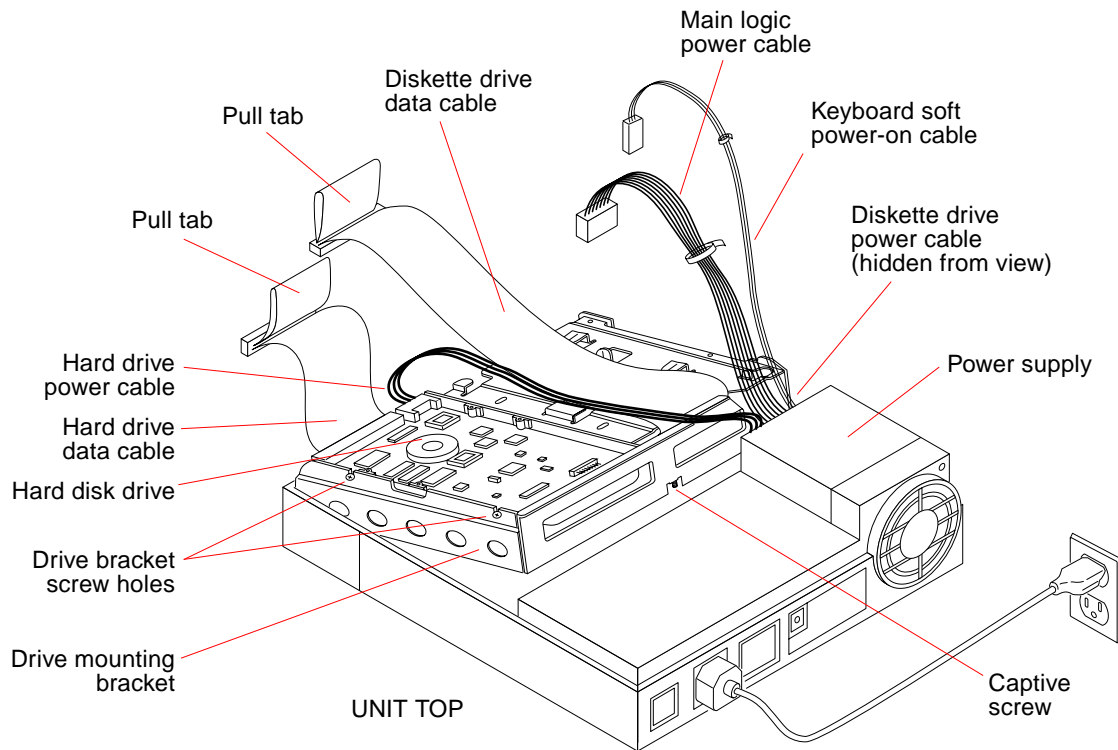

FIGURE 9-13 Removing the Disk Drive Mounting Bracket

5. Remove the disk drive mounting bracket.

- a. Carefully bend the power cables where they exit the power supply so that the mounting bracket can be removed without snagging or cutting the cables.
- b. Tilt the bracket up and away from the power supply (see FIGURE 9-13).
- c. Lift the bracket out of the system unit and place it on an antistatic mat.

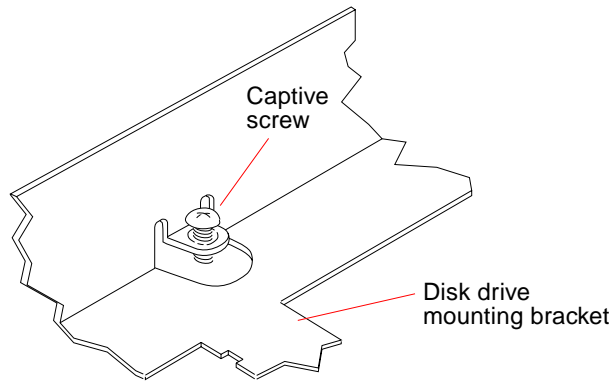

FIGURE 9-14 Detail of Disk Drive Mounting Bracket

9.2.2 Replacing the Disk Drive Mounting Bracket

To replace the disk drive mounting bracket:

1. Preparation.

Before setting the disk drive bracket flat in the unit top, connect the power cable to the diskette drive (if present) and the data cable to the hard drive (see FIGURE 9-15 and FIGURE 9-16).

2. Install the bracket.

Tilt the disk drive bracket toward the front of the unit. Gently lower the bracket into position in front of the power supply (see FIGURE 9-15).

Note – The disk drive bracket must engage a securing ridge at the inside front of the unit top. If the bracket is installed incorrectly, you will not be able to insert diskettes into the diskette drive.

3. Tighten the captive screw.

Tighten the captive Phillips-head screw at the center rear of the bracket to secure it to the chassis. Be careful not to overtighten the screw or damage may result.

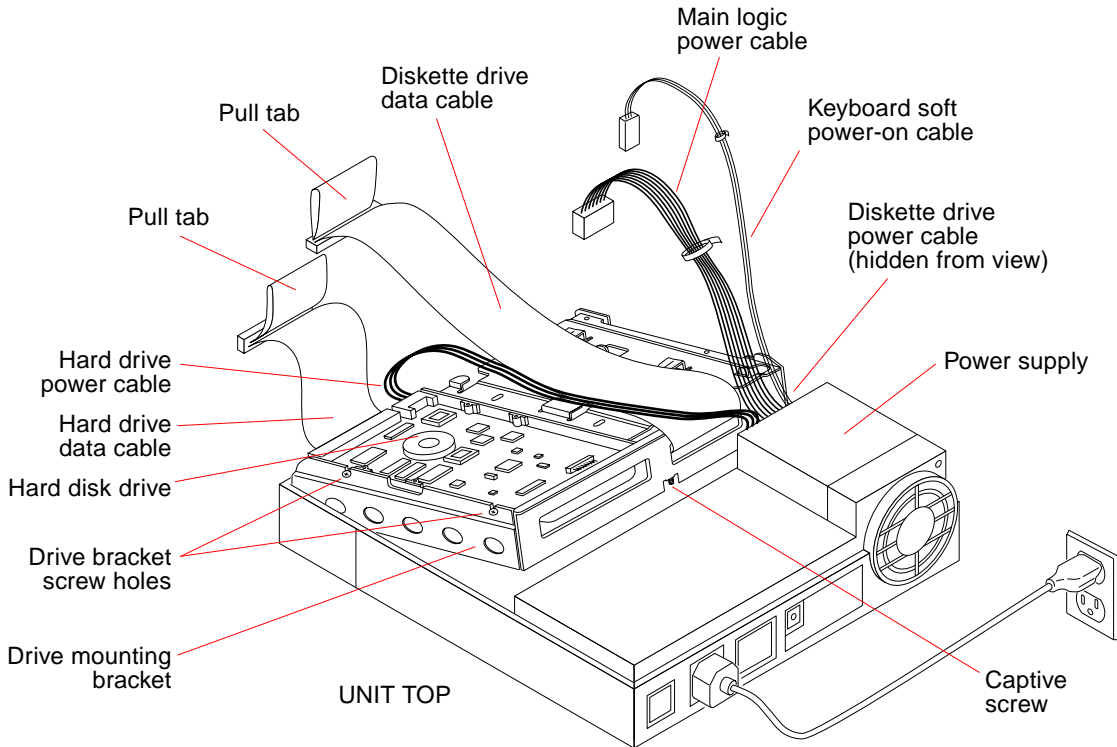

FIGURE 9-15 Replacing the Disk Drive Mounting Bracket

4. Reconnect the cables (see FIGURE 9-15).

Each connector is keyed to fit only one way. For connector locations on the main logic board, see Chapter 11 “Main Logic Board and Component Replacement.”

a. Connect the power cable to the hard disk drive.

b. Secure the diskette drive data cable (if present) and the power supply wiring harness in the cable management guides above the diskette drive (see FIGURE 9-12).

c. Connect the hard disk data cable and the diskette drive data cable (if present) to their respective connectors on the main logic board (see FIGURE 9-15).

d. Connect the internal power cable and the keyboard soft power-on cable to their respective connectors on the main logic board.

5. Refer to Chapter 7 “Internal Access” to perform the following procedures:

- Detaching the wrist strap
- Closing the system unit

- Reconnecting system components

6. Refer to Chapter 6 “Power Off and On to turn the power on.

9.3 Diskette Drive

The diskette drive is in the unit top at the front right side (see FIGURE 9-12). A 34-pin data cable and a 4-pin power cable connect to the rear of the drive. Four Phillips-head screws attach the diskette drive to the mounting bracket. The drive and the mounting bracket (described previously) are secured to the chassis by a single captive Phillips-head screw at the center rear of the bracket. See FIGURE 9-14 and FIGURE 9-16.



Caution – The hard disk drive and diskette drive contain electronic components that are extremely sensitive to static electricity. Ordinary amounts of static from your clothes or work environment can destroy the components. Do not touch the components themselves or any metal parts. Always wear a grounding strap when handling these drives. Attach the strap to your wrist and to the metal casing of the power supply.



Caution – The AC power cord should remain attached between the system unit and an AC wall outlet. This connection provides the ground path necessary to protect internal system components from harmful static discharges. Inside the system unit, be sure the power supply wiring harness is connected to the main logic board to complete the ground.



Caution – Verify that the system power switch is in the Standby position. The green LED at the front of the system unit should not be lit and the fan should not be running. When the system power switch is in the Standby position, and the AC power cord remains connected to a power outlet, hazardous AC voltage is still present in the power supply primary. Do not attempt to service the power supply under these conditions. Disconnect the AC power cord prior to handling the power supply. When servicing any other system component, the AC power cord should remain connected and poses no safety hazard.

9.3.1 Removing the Diskette Drive

To remove the diskette drive:

1. Preparation.

Follow the instructions for removing the disk drive mounting bracket in Section 9.2.1 "Removing the Disk Drive Mounting Bracket."

2. Remove the four Phillips-head screws holding the diskette drive to the disk drive mounting bracket (see FIGURE 9-16).

3. Remove the diskette drive from the bracket.

Slide the diskette drive out of the bracket as shown in FIGURE 9-16 and place it on an antistatic mat.

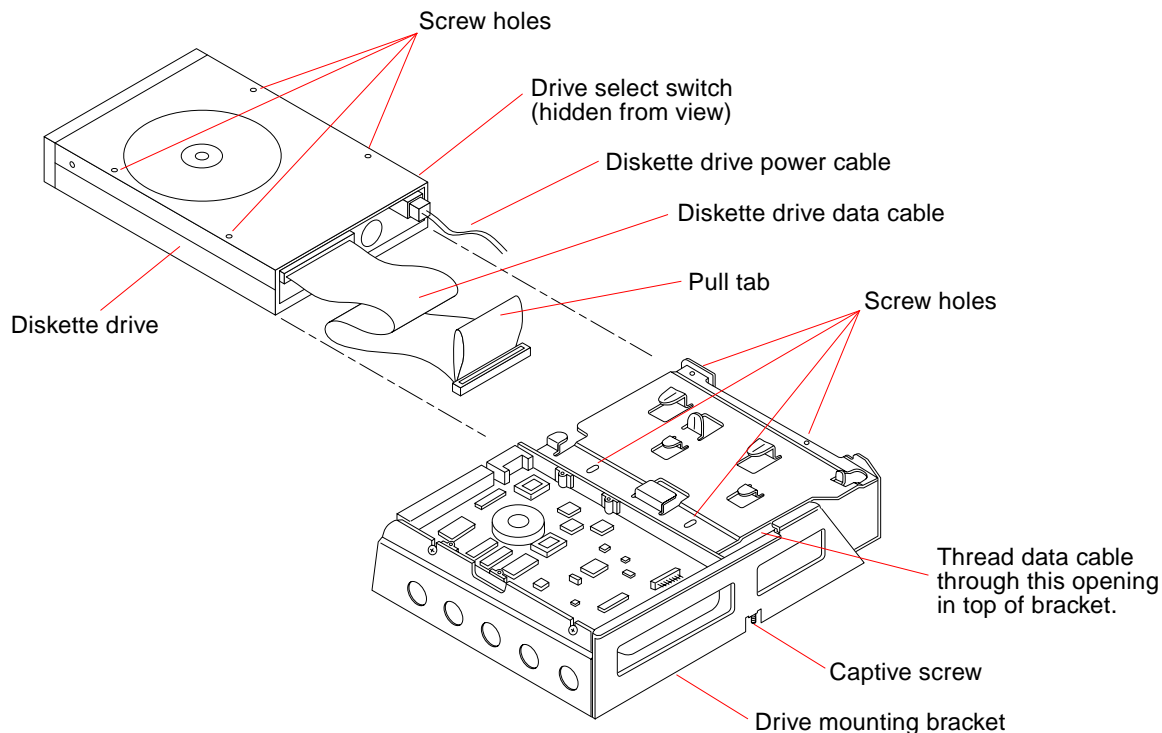

FIGURE 9-16 Disk Drive Mounting Bracket

4. Detach the diskette drive data cable.

Detach the data cable from the diskette drive and set it aside for use with the replacement drive.

This completes the diskette drive removal process.

9.3.2 Replacing the Diskette Drive

To replace the diskette drive:

- 1. Remove the defective diskette drive as instructed in the preceding section.**
- 2. On the replacement drive, verify the proper setting of the drive select switch.**
Make sure the switch position matches that of the defective drive. See FIGURE 9-16 for the switch location.
- 3. Connect the data cable to the replacement drive (see FIGURE 9-16).**
Use the end of the cable that has no pull tab. The connector is keyed so it will fit only one way.
- 4. Install the diskette drive (see FIGURE 9-16).**
 - a. Slide the diskette drive and attached cable into the cavity in the disk drive mounting bracket. Make sure the drive's printed circuit board is facing up.**
 - b. Thread the data cable through the opening on top of the drive mounting bracket.**
 - c. Align the four screw holes in the mounting bracket with the holes in the diskette drive, insert the screws, and fasten the diskette drive securely in the bracket.**
- 5. Replace the disk drive mounting bracket in the unit top.**
See Section 9.2.2 "Replacing the Disk Drive Mounting Bracket" on page 9-19.

System Board Overview

This chapter describes how to prepare for replacing the system board and its components and assemblies when you are replacing parts. Each SPARCclassic/SPARCclassic X/SPARCstation LX system board is illustrated and their customer replaceable units (CRUs) identified.

- Section 10.1 “Before You Begin”
- Section 10.2 “Damage Prevention”
- Section 10.3 “Handling System Boards and Assemblies”
- Section 10.4 “Main Logic Board Layouts”
- Section 10.5 “Identifying Replaceable System Board Components”

10.1 Before You Begin

Before you begin to replace CRUs, make sure you do the following:

- Halt your system
- Gather the proper tools
- Disconnect external peripherals (if any)
- Open the system unit
- Attach a wrist strap

Instructions for the procedures listed above are described in Chapter , “Power Off and On, and in Chapter , “Internal Access.

10.2 Damage Prevention



Caution – Use an antistatic mat (the part number is listed in Chapter 12 “Illustrated Parts Breakdown”) when working with the system board. An antistatic mat contains the amount of cushioning needed to protect the underside components, to prevent board flexing, and to provide antistatic protection.

10.3 Handling System Boards and Assemblies



Caution – Verify that the system power switch is in the Standby position. The green LED at the front of the system unit should not be lit and the fan should not be running. When the system power switch is in the Standby position, and the AC power cord remains connected to a power outlet, hazardous AC voltage is still present in the power supply primary. Do not attempt to service the power supply under these conditions. Disconnect the AC power cord prior to handling the power supply. When servicing *any other* system component, the AC power cord should remain connected and poses no safety hazard.



Caution – The AC power cord should remain attached between the system unit and an AC wall outlet. This connection provides the ground path necessary to protect internal system components from harmful static discharges. Inside the system unit, be sure the power supply wiring harness is connected to the main logic board to complete the ground.



Caution – Printed circuit boards are made of delicate electronic components that are extremely sensitive to static electricity. Ordinary amounts of static from your clothes or work environment can destroy the boards. Handle boards only by the non-conducting edges. Do not touch the components themselves or any metal parts. Always wear a grounding (wrist) strap when handling the boards. Attach the wrist strap to the metal casing of the power supply at the rear of the unit top.



Caution – Hot surface. Avoid contact. Surfaces are hot and may cause personal injury if touched.



Caution – The system board and related modules and cards have surface-mount components which may break when the board is flexed.

To minimize the amount of board flexing, observe the following precautions:

- Hold the system board only by the edges.
- Do not place the system board on a hard surface. Use a cushioned antistatic mat. See Chapter 12 “Illustrated Parts Breakdown,” for the part number.
- Transport the board in an antistatic bag.

Protect yourself and the equipment by observing the safety precautions described in TABLE 10-1.

TABLE 10-1 Safety Precautions

Item	Problem	Precaution
AC power cord	ESD (Electrostatic discharge)	Make sure that the power cord connects the system to a grounded electrical outlet. The power cord provides a ground path for the system unit.
	Electric shock	Make sure that the system power switch is in the standby position before opening the system for service.
Wrist strap	ESD	Wear a wrist strap when handling printed circuit boards.
ESD mat	ESD	Use the antistatic mat (see Chapter 12 “Illustrated Parts Breakdown”) when working on a printed circuit board. In addition to providing ESD protection, the mat also cushions the board to prevent breakage of parts mounted on the bottom of the board.
Printed circuit boards	ESD	Handle a printed circuit board by the edges only. Store a board in an antistatic bag.
Cover	System damage and overheating	Replace the cover to keep out foreign objects and to prevent overheating.
Filler panels	System damage and overheating	Install filler panels in all unused SBus board slots. Open slots severely reduce the correct airflow in the system and can lead to equipment damage.

The following items are customer replaceable units.

10.4 Main Logic Board Layouts

The main logic board (MLB) resides in the bottom half of each system unit (see FIGURE 10-4). FIGURE 10-1 shows a simplified layout of the SPARCclassic and the SPARCclassic X terminal main logic board. TABLE 10-2 lists acronyms and abbreviations for certain components.

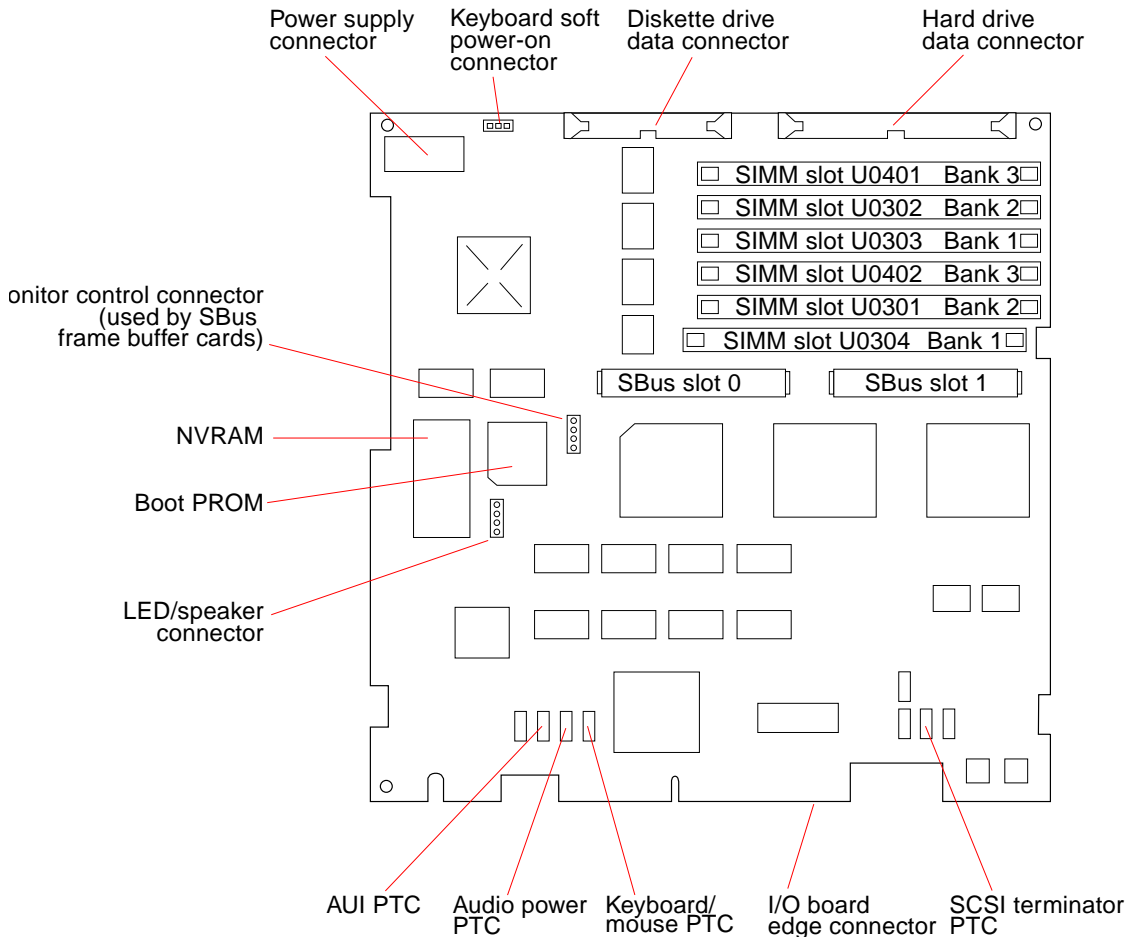

FIGURE 10-1 Main Logic Board Layout—SPARCclassic/SPARCclassic X Systems

FIGURE 10-2 and FIGURE 10-3 illustrate the SPARCstation LX main logic boards.

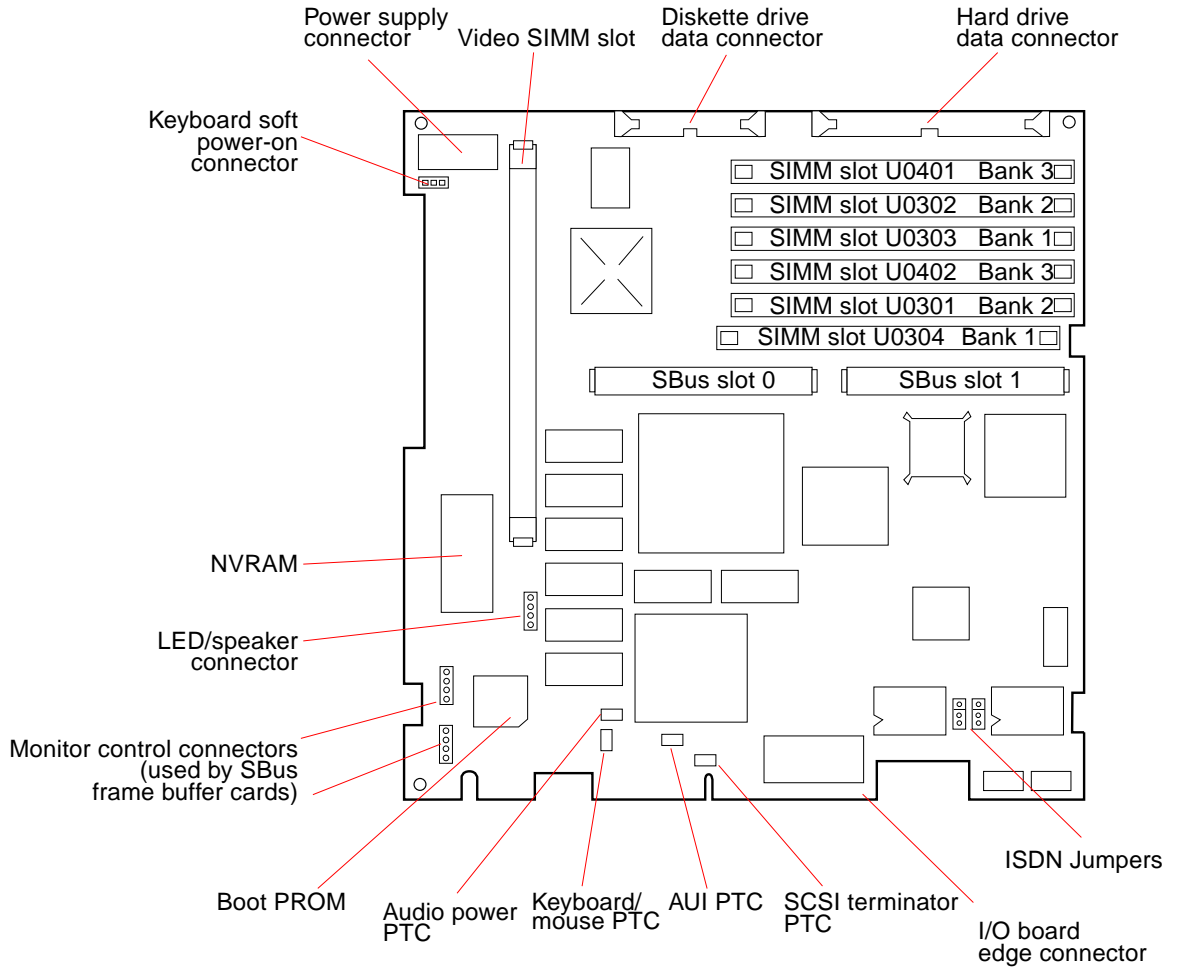

FIGURE 10-2 Main Logic Board Layout—SPARCstation LX System (Part 270-2233)

Visually identify each CRU by looking at the appropriate system board layout illustration from FIGURE 10-1, FIGURE 10-2, or FIGURE 10-3, and by looking at the unit bottom illustration in FIGURE 10-4. TABLE 10-2 lists acronyms and abbreviations for certain components of the MLB.

TABLE 10-2 Acronyms for Components of the Main Logic Board

Acronym/Abbreviation	Full Expression
NVRAM	Nonvolatile Random Access Memory
PROM	Programmable Read-Only Memory
PTC	Positive Temperature Coefficient
DRAM	Dynamic Random Access Memory
DSIMM	Dynamic Single In-line Memory Module
VSIMM	Video Single In-line Memory Module
AUI	Attachment Unit Interface (Ethernet adapter cable)
LED	Light-Emitting Diode
ISDN	Integrated Services Digital Network

The SPARCclassic/SPARCclassic X/SPARCstation LX system board CRUs are listed below.

Unit bottom

- DSIMMs
- VSIMM
- SBus cards
- Speaker/power LED assembly
- Main logic board
- NVRAM
- System I/O board

Internal cables

- Diskette drive data cable (*Not applicable to SPARCclassic X terminal*)
- Hard disk drive data cable (*Not applicable to SPARCclassic X terminal*)

Note – As noted in the part labels shown in FIGURE 10-4, some items are not applicable to the SPARCclassic X terminal.

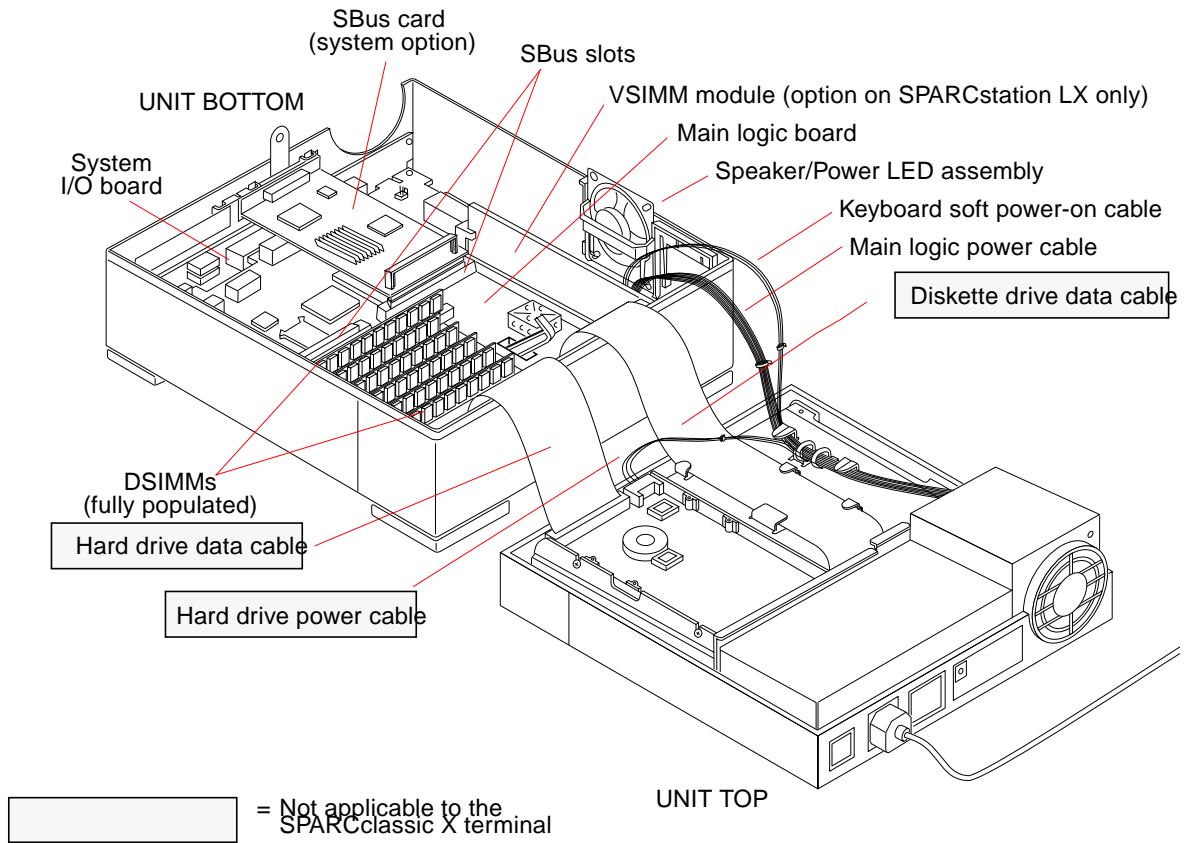

FIGURE 10-4 View of Open System Unit

Main Logic Board and Component Replacement

This chapter describes procedures for removing and replacing the main logic board and its components. In addition, the default SPARCstation LX ISDN jumper settings are also described.

- Section 11.1 “SBus Cards”
- Section 11.2 “Video SIMM (VSIMM)”
- Section 11.3 “DRAM Single In-line Memory Modules (DSIMMs)”
- Section 11.4 “Main Logic Board”
- Section 11.5 “Nonvolatile RAM (NVRAM)”
- Section 11.6 “SPARCstation LX ISDN Jumper Settings”

11.1 SBus Cards

This section describes the procedures for removing and replacing a faulty SBus card. If you are adding a new SBus card, and not replacing one, refer instead to the *Desktop SPARC Hardware Owner's Guide* and the documentation supplied with the new card.

11.1.1 Removing SBus Cards

To remove an SBus card from the system unit:

1. Prepare to work on the system as described in Chapter 6 “Power Off and On, and in Chapter 7 “Internal Access.

Halt the system and verify that the power LED is not lit and the fan is not running. Then open the system unit and attach a wrist strap as described in Section 7.3 “Attaching the Wrist Strap.



Caution – The AC power cord should remain attached between the system unit and an AC wall outlet. This connection provides the ground path necessary to protect internal system components from harmful static discharges. Inside the system unit, be sure the power supply wiring harness is connected to the main logic board to complete the ground.



Caution – Verify that the system power switch is in the Standby position. The green LED at the front of the system unit should not be lit and the fan should not be running. When the system power switch is in the Standby position, and the AC power cord remains connected to a power outlet, hazardous AC voltage is still present in the power supply primary. Do not attempt to service the power supply under these conditions. Disconnect the AC power cord prior to handling the power supply. When servicing any other system component, the AC power cord should remain connected and poses no safety hazard.

2. Place the antistatic mat, shiny side up, next to the system unit.

The mat is supplied with the replacement SBus card.

3. Detach any external cables connected to the faulty SBus card (if applicable).

4. Detach any internal cables leading from the SBus card to the main logic board (if applicable).

Detach the cables from their connectors on the main logic board.

5. Remove the faulty SBus card.

Place your index fingers or thumbs beneath the corners of the SBus card where it plugs into its slot. Lift up the card to release it from the slot (see FIGURE 11-1).



Caution – The plastic SBus card retainer is not a handle. Pulling on the SBus card retainer can cause it to break.

6. Place the SBus card on an antistatic mat.

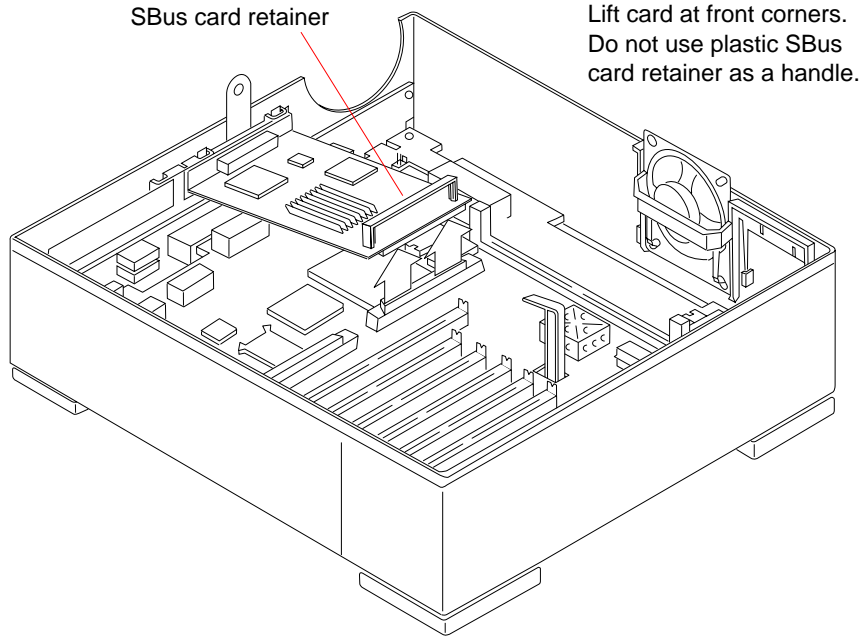

FIGURE 11-1 Removing the SBus Card

7. Replace the SBus slot filler panel (if necessary).

If you will not be installing a replacement SBus card, install the filler panel before closing the system unit (FIGURE 11-2). Failure to do so can cause cooling problems inside the system unit.

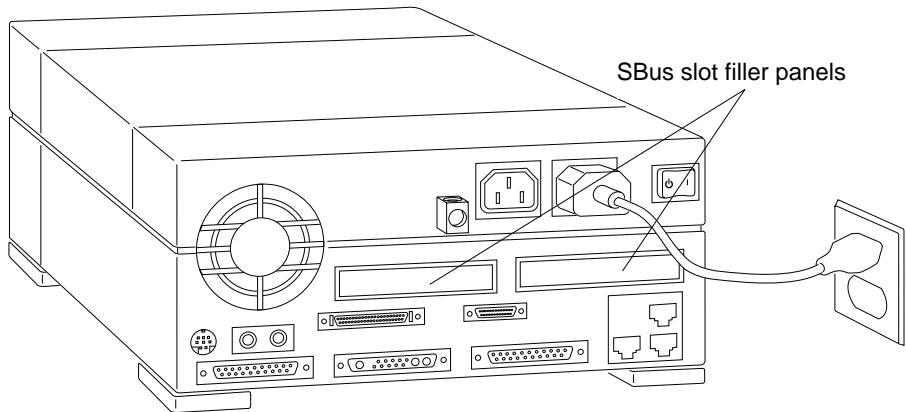

FIGURE 11-2 SBus Slot Filler Panels

11.1.2 Replacing SBus Cards



Caution – Verify that the system power switch is in the Standby position. The green LED at the front of the system unit should not be lit and the fan should not be running. When the system power switch is in the Standby position, and the AC power cord remains connected to a power outlet, hazardous AC voltage is still present in the power supply primary. Do not attempt to service the power supply under these conditions. Disconnect the AC power cord prior to handling the power supply. When servicing any other system component, the AC power cord should remain connected and poses no safety hazard.

To install a replacement SBus card in the system unit:

1. Remove the faulty SBus card.

See Section 11.1.1 “Removing SBus Cards” on page 11-1. Make sure you use the wrist strap and antistatic mat. Be sure to remember which slot contained the faulty SBus card.

2. Read the manual supplied with the replacement SBus card.

Pay particular attention to the section describing the jumper or switch settings, slot requirements, and tools needed.

3. Remove the replacement card from its antistatic bag. Hold the card by the edges.

Place the SBus card on an antistatic surface (either an antistatic mat or the antistatic bag in which the card was shipped).

4. If required, set the jumpers or switches on the card.

Refer to the manual supplied with the replacement SBus card.

5. Align the mounting plate of the new SBus card with the rectangular opening in the system unit’s back panel (see FIGURE 11-3 and FIGURE 11-4).

Position the card in the same location that the faulty card occupied. Insert the two locating tabs on the card’s mounting plate into the slots above the rectangular opening in the back panel.

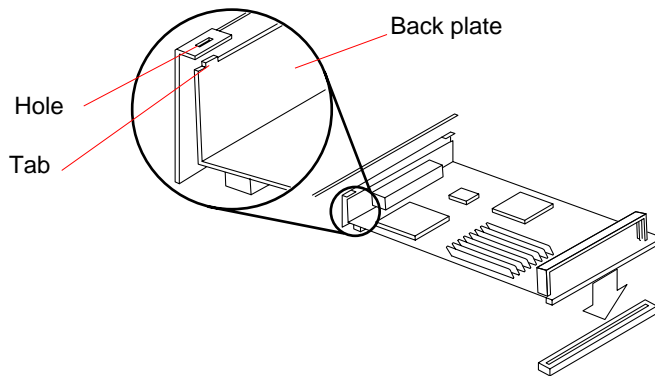

FIGURE 11-3 Positioning the SBus Card

6. Connect the SBus card to its slot.

Align the connector on the card with the SBus slot on the main logic board. Press gently on the corners of the SBus card until the connection is secure (see FIGURE 11-4). *Do not force the card.*



Caution – Do not press down on the SBus card retainer, as this can cause it to break. Using excessive force to secure the connection may bend or damage the connector pins.

- 7. Refer to the manual supplied with the replacement card for instructions on any additional hardware setup.**
- 8. Attach any internal cables leading from the SBus card to the main logic board (if applicable).**
- 9. Attach any external cables that must be connected to the SBus card (if applicable).**

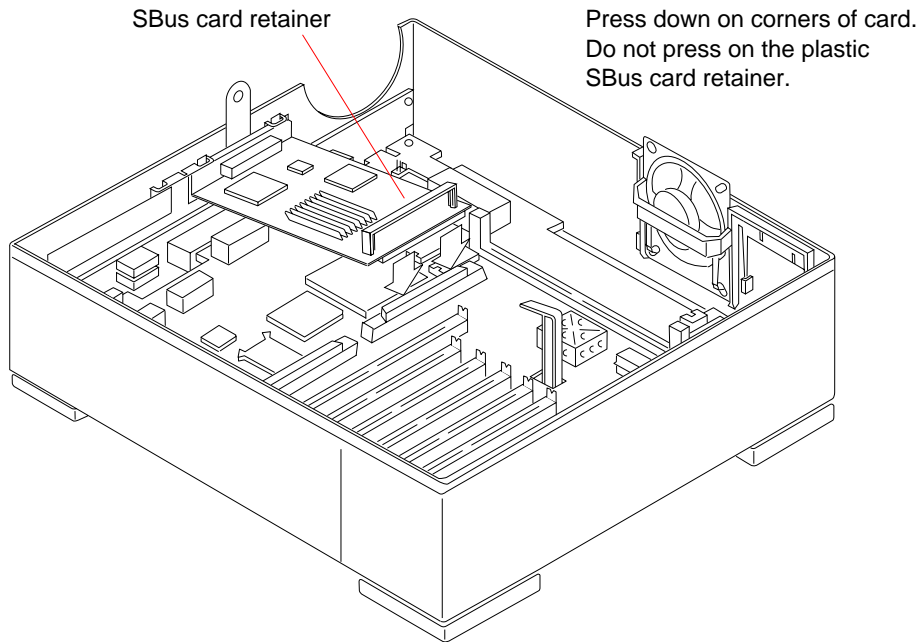

FIGURE 11-4 Connecting the SBus Card

10. Refer to Chapter 7 "Internal Access to perform the following procedures:
 - Detaching the wrist strap
 - Closing the system unit
 - Reconnecting system components
11. Refer to Chapter 6 "Power Off and On to turn the power on.
12. Refer to the guide for your SBus product to complete any required software installation, configuration, or additional setup procedures.

11.2 Video SIMM (VSIMM)

This section describes the procedures for removing and replacing a faulty Video SIMM. The VSIMM is an option on SPARCstation LX systems only. Complete installation procedures can be found in *Installing SPARCclassic/SPARCclassic X/SPARCstation LX DSIMMs and VSIMMs*.

11.2.1 Removing the VSIMM



Caution – Printed circuit boards are made of delicate electronic components that are extremely sensitive to static electricity. Ordinary amounts of static from your clothes or work environment can destroy the boards. Handle boards only by the nonconducting edges. Do not touch the components themselves or any metal parts. Always wear a grounding (wrist) strap when handling the boards. Attach the wrist strap to the metal casing of the power supply at the rear of the unit top.

To remove the VSIMM from the system unit:

1. **Prepare to work on the system as described in Chapter 6 “Power Off and On, and in Chapter 7 “Internal Access.**

Halt the system and verify that the power LED is not lit and the fan is not running. Then open the system unit and attach a wrist strap as described in Section 7.3 “Attaching the Wrist Strap.



Caution – The AC power cord should remain attached between the system unit and an AC wall outlet. This connection provides the ground path necessary to protect internal system components from harmful static discharges. Inside the system unit, be sure the power supply wiring harness is connected to the main logic board to complete the ground.



Caution – Verify that the system power switch is in the Standby position. The green LED at the front of the system unit should not be lit and the fan should not be running. When the system power switch is in the Standby position, and the AC power cord remains connected to a power outlet, hazardous AC voltage is still present in the power supply primary. Do not attempt to service the power supply under these conditions. Disconnect the AC power cord prior to handling the power supply. When servicing any other system component, the AC power cord should remain connected and poses no safety hazard.

2. **Locate the VSIMM slot on the main logic board.**

See FIGURE 11-5.

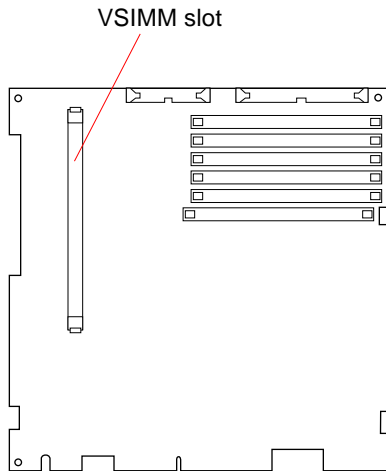

FIGURE 11-5 VSIMM Slot Location

3. Place an antistatic mat, shiny side up, next to the system unit.

The mat is supplied with the replacement VSIMM.

4. Remove the faulty VSIMM.

Grasp the VSIMM at its top corners and carefully wiggle it free from its connector (see FIGURE 11-6). Be careful not to touch any of the components on the VSIMM.

5. Place the VSIMM on the antistatic mat.

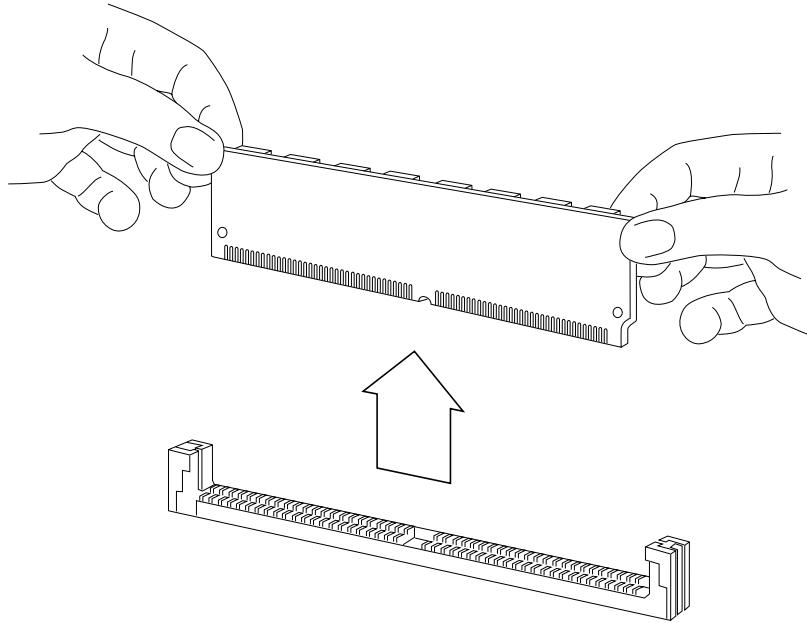

FIGURE 11-6 Removing the VSIMM

11.2.2 Replacing the VSIMM



Caution – Verify that the system power switch is in the Standby position. The green LED at the front of the system unit should not be lit and the fan should not be running. When the system power switch is in the Standby position, and the AC power cord remains connected to a power outlet, hazardous AC voltage is still present in the power supply primary. Do not attempt to service the power supply under these conditions. Disconnect the AC power cord prior to handling the power supply. When servicing any other system component, the AC power cord should remain connected and poses no safety hazard.



Caution – The SIMMs installed in your system must be specifically designed to operate in it. *Do not* transfer a SIMM from a different Sun system unless you are sure it is compatible with your system.

To replace the VSIMM on the main logic board:

1. Remove the faulty VSIMM.

See Section 11.2.1 “Removing the VSIMM” on page 11-7. Make sure you use the wrist strap and antistatic mat.

2. Install the new VSIMM.

The VSIMM is keyed so it can be installed only in one way. Grasp the VSIMM by its top corners and align it with its connector (see FIGURE 11-7). Applying equal pressure to both corners, push down the VSIMM until it is firmly seated in its connector.

3. Refer to Chapter 7, “Internal Access,” to perform the following procedures:

- Detaching the wrist strap
- Closing the system unit
- Reconnecting system components

4. Refer to Chapter 6 “Power Off and On to turn the power on.

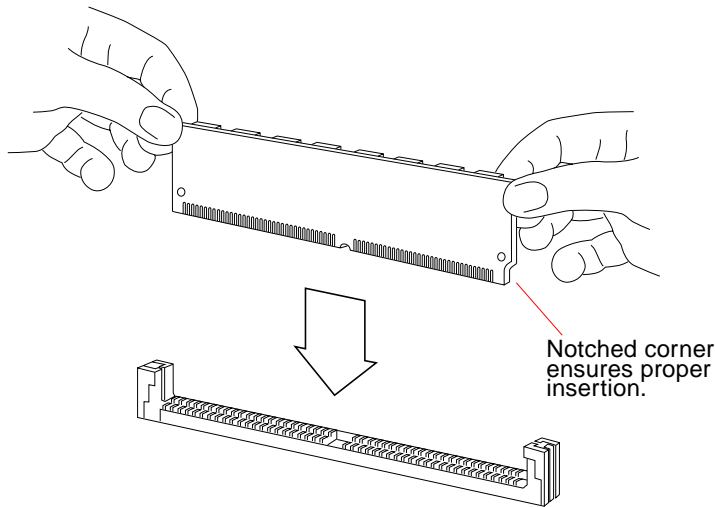

FIGURE 11-7 Installing the VSIMM

11.3 DRAM Single In-line Memory Modules (DSIMMs)

This section describes the procedures for removing and replacing faulty DSIMMs. To determine the location of a faulty DSIMM, see Section 4.4 “Determining Faulty DSIMM Locations” on page 4-7.

11.3.1 DSIMM Configurations

The main logic board contains six DSIMM slots capable of accepting either 1-, 2-, 4-, or 16-megabyte DSIMMs. The six DSIMM slots are logically grouped into three memory banks, with two DSIMM slots to a bank. Each slot is labeled 1, 2, or 3 to indicate its corresponding memory bank.

You can combine different types of DSIMMs in the same system, but you must observe the following restriction: The two DSIMM slots within each bank must be identically configured (that is, they should both contain the same type of DSIMM or else both should be empty).

FIGURE 11-8 shows a typical DSIMM. If you are merely expanding memory, and not repairing it, refer instead to the document supplied with your memory upgrade, *Installing SPARCclassic/SPARCclassic X/SPARCstation LX SIMMs*.

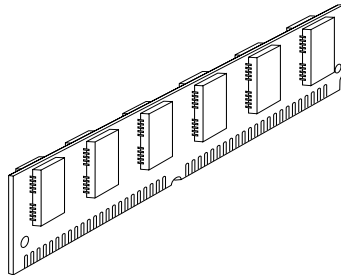

FIGURE 11-8 Typical DSIMM

FIGURE 11-9 shows the DSIMM slot locations on the main logic board. TABLE 11-1 shows the configuration matrix for the SPARCclassic X terminal using 1-,2-,4-, and 16-megabyte memory modules. TABLE 11-2 shows the configuration matrix using 4- and 16-megabyte memory modules. The maximum memory configuration is 96 megabytes using six 16-megabyte DSIMMs.

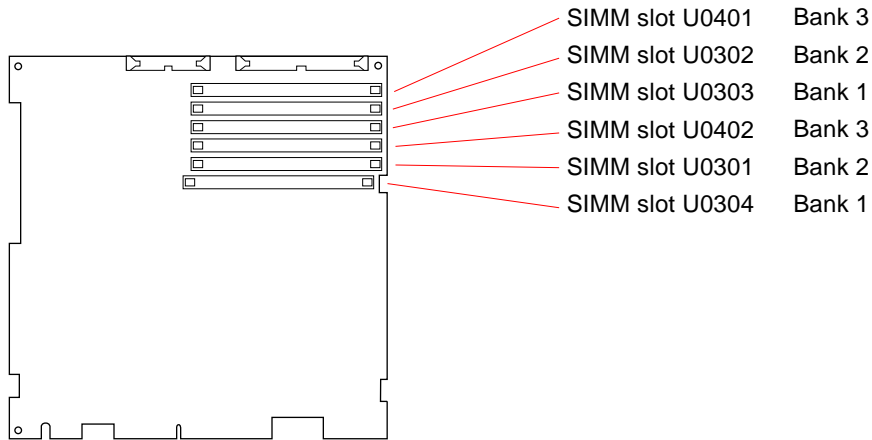

FIGURE 11-9 DSIMM Slot Locations

TABLE 11-1 Memory Configuration Matrix—SPARCclassic X Terminal

Total	Slot	Slot	Slot	Slot	Slot	Slot
Memory	U0304	U0301	U0402	U0303	U0302	U0401
8 MB	1 MB	1 MB	2 MB	1 MB	1 MB	2 MB
8 MB	2 MB	2 MB	—	2 MB	2 MB	—
8 MB	4 MB	—	—	4 MB	—	—
12 MB	1 MB	1 MB	4 MB	1 MB	1 MB	4 MB
12 MB	2 MB	4 MB	—	2 MB	4 MB	—
12 MB	2 MB	2 MB	2 MB	2 MB	2 MB	2 MB
16 MB	2 MB	2 MB	4 MB	2 MB	2 MB	4 MB
16 MB	4 MB	4 MB	—	4 MB	4 MB	—
20 MB	2 MB	4 MB	4 MB	2 MB	4 MB	4 MB
24 MB	4 MB	4 MB	4 MB	4 MB	4 MB	4 MB
32 MB	16 MB	—	—	16 MB	—	—
36 MB	1 MB	1 MB	16 MB	1 MB	1 MB	16 MB
36 MB	2 MB	16 MB	—	2 MB	16 MB	—
40 MB	2 MB	2 MB	16 MB	2 MB	2 MB	16 MB
40 MB	4 MB	16 MB	—	4 MB	16 MB	—
44 MB	2 MB	4 MB	16 MB	2 MB	4 MB	16 MB

TABLE 11-1 Memory Configuration Matrix—SPARCclassic X Terminal (Continued)

Total	Slot	Slot	Slot	Slot	Slot	Slot
48 MB	4 MB	4 MB	16 MB	4 MB	4 MB	16 MB
64 MB	16 MB	16 MB	—	16 MB	16 MB	—
68 MB	2 MB	16 MB	16 MB	2 MB	16 MB	16 MB
72 MB	4 MB	16 MB	16 MB	4 MB	16 MB	16 MB
96 MB	16 MB	16 MB	16 MB	16 MB	16 MB	16 MB

TABLE 11-2 Configuration Matrix for Memory Modules

Total	Slot	Slot	Slot	Slot	Slot	Slot
Memory	U0304	U0301	U0402	U0303	U0302	U0401
16 MB	4 MB	4 MB	—	4 MB	4 MB	—
24 MB	4 MB	4 MB	4 MB	4 MB	4 MB	4 MB
32 MB	16 MB	—	—	16 MB	—	—
40 MB	4 MB	16 MB	—	4 MB	16 MB	—
48 MB	4 MB	4 MB	16 MB	4 MB	4 MB	16 MB
64 MB	16 MB	16 MB	—	16 MB	16 MB	—
72 MB	4 MB	16 MB	16 MB	4 MB	16 MB	16 MB
96 MB	16 MB	16 MB	16 MB	16 MB	16 MB	16 MB

11.3.2 Removing a DSIMM

The procedure for removing a DSIMM is the same regardless of the type of DSIMM.



Caution – Printed circuit boards are made of delicate electronic components that are extremely sensitive to static electricity. Ordinary amounts of static from your clothes or work environment can destroy the boards. Handle boards only by the edges. Do not touch the components themselves or any metal parts. Always wear a grounding (wrist) strap when handling the boards. Attach the wrist strap to the metal casing of the power supply at the rear of the unit top.



Caution – The AC power cord should remain attached between the system unit and an AC wall outlet. This connection provides the ground path necessary to protect internal system components from harmful static discharges. Inside the system unit, be sure the power supply wiring harness is connected to the main logic board to complete the ground.



Caution – Verify that the system power switch is in the Standby position. The green LED at the front of the system unit should not be lit and the fan should not be running. When the system power switch is in the Standby position, and the AC power cord remains connected to a power outlet, hazardous AC voltage is still present in the power supply primary. Do not attempt to service the power supply under these conditions. Disconnect the AC power cord prior to handling the power supply. When servicing any other system component, the AC power cord should remain connected and poses no safety hazard.

To remove a DSIMM:

1. Prepare to work on the system as described in Chapter 6 “Power Off and On,” and in Chapter 7, “Internal Access.”

Halt the system and verify that the power LED is not lit and the fan is not running. Then open the system unit and attach a wrist strap as described in Section 7.3 “Attaching the Wrist Strap. Be sure to leave the system unit plugged in to an AC wall outlet to provide a proper ground path.

2. Locate the DSIMM slots on the main logic board.

See FIGURE 11-9.

3. Place an antistatic mat, shiny side up, next to the system unit.

The mat is supplied with the replacement DSIMMs.

4. Locate and remove the faulty DSIMM.

See Section 4.4 “Determining Faulty DSIMM Locations” on page 4-7.

The DSIMMs are held in their slots by metal clips. To release the modules, pry apart the clips with your fingernails while pushing the top of the module gently forward about 30 degrees from the vertical position (see FIGURE 11-6). Then pull the DSIMM out of its socket.

Any DSIMMs you remove should be placed on the antistatic mat.

Note – The DSIMMs are closely spaced. In order to remove a DSIMM, you may need to remove adjacent DSIMMs first. Keep track of which DSIMMs are installed in which slots. If you are removing a defective DSIMM, take care not to get it mixed up with the other DSIMMs.

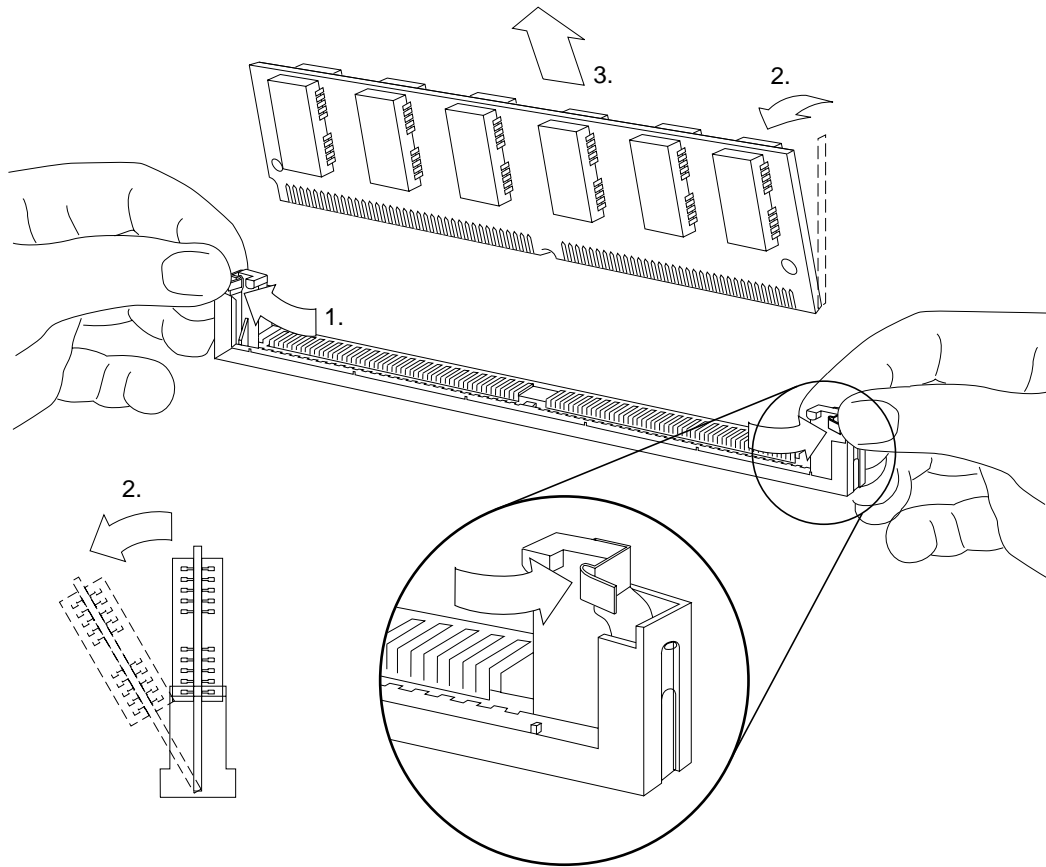

FIGURE 11-10 Removing a DSIMM

11.3.3 Replacing a DSIMM

The procedure for replacing a DSIMM is the same regardless of the type of SIMM.



Caution – The SIMMs installed in your system must be specifically designed to operate in it. *Do not* transfer a SIMM from a different Sun system unless you are sure it is compatible with your system.



Caution – Verify that the system power switch is in the Standby position. The green LED at the front of the system unit should not be lit and the fan should not be running. When the system power switch is in the Standby position, and the AC power cord remains connected to a power outlet, hazardous AC voltage is still present in the power supply primary. Do not attempt to service the power supply under these conditions. Disconnect the AC power cord prior to handling the power supply. When servicing any other system component, the AC power cord should remain connected and poses no safety hazard.

To replace a DSIMM:

1. Identify and remove the faulty DSIMM.

See Section 11.3.2 “Removing a DSIMM” on page 11-13. Make sure you use the wrist strap and antistatic mat. For any DSIMM you remove, be sure to note its original slot.

2. Remove the replacement DSIMM from its protective packaging, and place it on the antistatic mat.

3. Determine where to install the new DSIMM and any others you may have removed.

The replacement DSIMM should go where the faulty DSIMM was located. Any other DSIMMs you removed should go in the slots where they were originally installed.

Note – The six DSIMM slots are logically grouped into pairs—labeled 1, 2, and 3. When installing DSIMMs, you must make sure that each pair of DSIMM slots is identically configured. For more information, see the discussion of paired DSIMMs in Section 11.3 “DRAM Single In-line Memory Modules (DSIMMs).”

4. Install the DSIMMs.

Since the DSIMMs are closely spaced, they must be installed in the proper order. Start with the slot closest to the center of the main logic board and work outward toward the board’s front edge.

Hold each DSIMM at its edges and insert it into the plastic guides at an angle about 30 degrees from the vertical position (see FIGURE 11-11). Then, by pushing gently on its top edge, rotate the DSIMM into an upright position. You should hear it click into place.

Note – Each DSIMM is keyed so it can only be installed in one way.

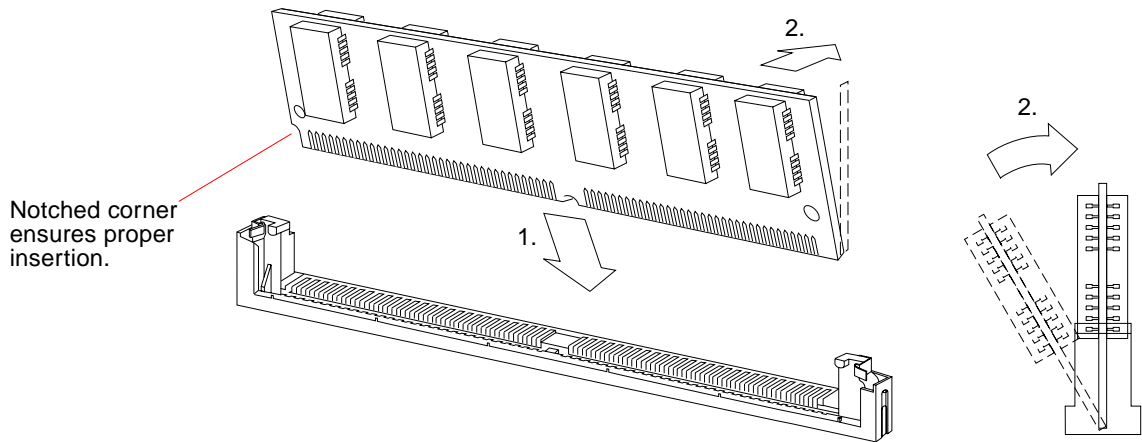

FIGURE 11-11 Installing a DSIMM

5. Refer to Chapter 7, “internal Access,” to perform the following procedures:
 - Detaching the wrist strap
 - Closing the system unit
 - Reconnecting system components
6. Refer to Chapter 6, “Power Off and On,” to turn the power on.



Caution – When you are finished installing parts inside the system unit, be sure to close the system unit before turning on the power. It is not safe to operate the system unit while it is open. See Section 7.4 “Closing the System Unit” on page 7-4 for instructions.

11.4 Main Logic Board

This section explains how to remove and replace the main logic board (MLB).

11.4.1 Main Logic Board Voltage Test Points

There are no voltage test points on the main logic board. If you need to measure voltages, the safest place is at the power supply connection on the main logic board (see FIGURE 11-12 and FIGURE 11-13). See Section 11.4.2 “Before Replacing the Main Logic Board” on page 11-21 for the connector wiring and voltages.



Caution – Printed circuit boards are made of delicate electronic components that are extremely sensitive to static electricity. Ordinary amounts of static from your clothes or work environment can destroy the boards. Handle boards only by the nonconducting edges. Do not touch the components themselves or any metal parts. Always wear a grounding (wrist) strap when handling the boards. Attach the wrist strap to the metal casing of the power supply at the rear of the unit top.



Caution – The AC power cord should remain attached between the system unit and an AC wall outlet. This connection provides the ground path necessary to protect internal system components from harmful static discharges. Inside the system unit, be sure the power supply wiring harness is connected to the main logic board to complete the ground.



Caution – Verify that the system power switch is in the Standby position. The green LED at the front of the system unit should not be lit and the fan should not be running. When the system power switch is in the Standby position, and the AC power cord remains connected to a power outlet, hazardous AC voltage is still present in the power supply primary. Do not attempt to service the power supply under these conditions. Disconnect the AC power cord prior to handling the power supply. When servicing any other system component, the AC power cord should remain connected and poses no safety hazard.

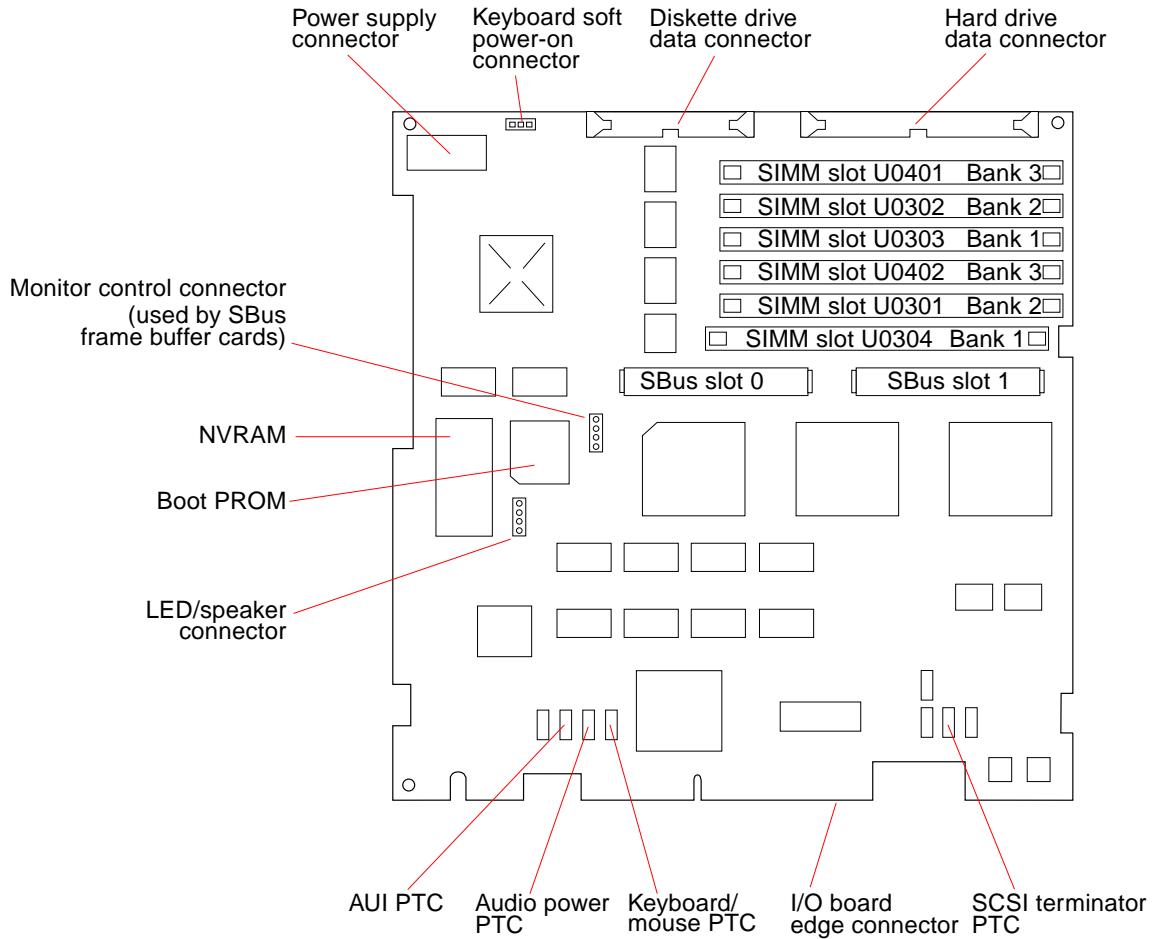

FIGURE 11-12 Main Logic Board Layout—SPARCclassic/SPARCclassic X

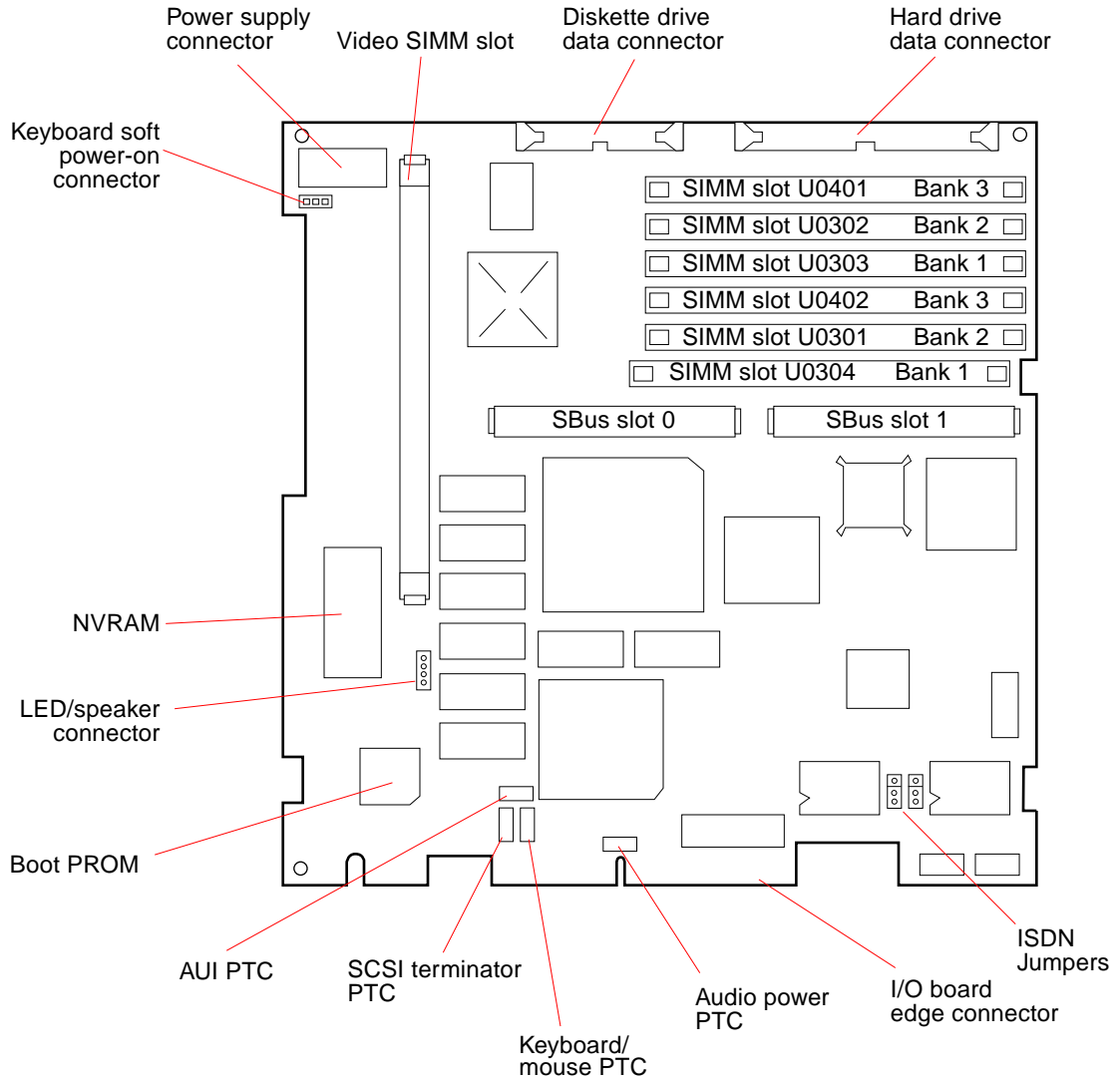

FIGURE 11-14 Main Logic Board Layout—SPARCstation LX (Part 270-2474)

11.4.2 Before Replacing the Main Logic Board

This section explains what steps to perform before removing and replacing the main logic board.

Note – Removing and replacing the main logic board is a drastic step to take. Therefore, it is important to try to troubleshoot all other possibilities before removing and replacing the main logic board.

To check for and eliminate other possible problems before you replace the main logic board, do the following:

1. Preparation.

- a. **Follow the instructions in Chapter 6 “Power Off and On,” and in Chapter 7 “Internal Access,” about halting your system, opening the system unit, and attaching a wrist strap. The wrist strap should be attached to the metal casing of the power supply inside the system unit.**
- b. **Make sure that the system unit’s power is in the Standby position by verifying that the green LED at the front of the chassis is not lit and that the fan in the power supply is not running. The AC power cord should remain attached to the system unit and AC wall outlet. Inside the system unit, the power supply wiring harness should remain connected to the main logic board to complete the ground.**
- c. **Attach a terminal to serial port A on the system unit. For details, see the *Desktop SPARC Hardware Owner’s Guide*. A terminal enables you to view the output of the POST results as they are run. Alternatively, you can set up a tip connection to another workstation; see Section 3.4.1 “Setting Up a tip Connection to Another Workstation” on page 3-5, for details.**
- d. **Disconnect the video monitor, the keyboard, and the Ethernet cable from the system unit.**
- e. **Remove any SBus cards from the system. See Section 11.1 “SBus Cards” for removal/replacement procedures.**
- f. **Disconnect the hard disk drive and the diskette drive from their power and data cables. See FIGURE 9-12 on page 9-17 and FIGURE 9-13 on page 9-18 for cable locations.**

2. Verify the connections of internal parts.

- a. **Make sure that all SIMMs are correctly seated, the power supply harness is connected to the main logic board, and all replaceable chips on the board are correctly seated in their sockets. (See FIGURE 11-12 and FIGURE 11-13 for SIMM locations.)**
- b. **Follow the directions in Chapter 6 “Power Off and On,” for turning on the power.**
- c. **Using a Volt-Ohmmeter (VOM), measure the power supply voltages at the 12-pin power connector on the main logic board.**



Caution – Voltage measurements will be inaccurate if the power supply wiring harness is not connected to the main logic board. Without load, the power supply will not regulate.

The colored wires of the power harness supply the following signals and voltages:

- Red: +5V
- Blue: +12V
- Brown: -12V
- Gray: POR (Power on reset)
- Black: Ground

Note – The POR signal is a Transistor-Transistor Logic (TTL) open collector and pull up is on the main logic board.

The limits for the voltages are:

- +5V: 4.90 to 5.10
- +12V: 11.16 to 12.84
- -12V: -11.6 to -13.2 with a hard drive
- -12V: -10.2 to -13.8 without a hard drive

If the voltages are correct, you can rule out a defective power supply.

1. Reconnect the cables and SBus cards one at a time and measure the voltages each time. In this way, you can determine whether one of the system components is holding down a power supply voltage.
 2. Close the system unit using the procedure in Section 7.4 “Closing the System Unit” on page 7-4.
- 3. Enter the Forth Toolkit.**
- a. Turn on the system and the terminal. The system will start to boot.
 - b. Interrupt the boot sequence by pressing the Break key on the terminal keyboard.
 - c. If you see the `ok` prompt, go to step 3-e. If you see the `>` prompt, continue with step 3-d.
 - d. At the `>` prompt, type `n` and press Return. When the `ok` prompt appears, you have entered the Forth Toolkit.

- e. Use the commands shown below to set the diagnostic switch to True, set the autoboot switch to False, and reset the system.

```
ok setenv diag-switch? true
ok setenv auto-boot? false
ok reset
```

As the POSTs run, view the results on the terminal screen.

- f. If all POSTs pass, go to step 5. Otherwise, proceed as follows:

- i. If the Limited Main Memory Address Test fails, the “U” number of the faulty DSIMM is displayed on the terminal. Replace the defective DSIMM using Section 11.3 “DRAM Single In-line Memory Modules (DSIMMs)” on page 11-10.

- ii. If any other POST fails, or the system appears dead, replace the main logic board. The appropriate removal/replacement procedures in Section 11.1 “SBus Cards.”

- g. If you replaced the main logic board or a DSIMM, return to step 3 of this procedure.

4. If you still have not identified the problem, go to the next step. Otherwise, skip ahead to step 7.

5. Run the SunDiagnostic Executive with the cache disabled.

The SunDiagnostic Executive is an independent operating system. It runs exhaustive subsystem tests independent of your system’s normal operating system. See the *SunDiagnostic Executive User’s Guide for Desktop SPARCstations*.

6. At the > or ok prompt, turn off the system’s power switch.

7. Disconnect the terminal and reconnect the graphics monitor, keyboard, and Ethernet connector.

See the *Desktop SPARC Hardware Owner’s Guide* or *Using a SPARCclassic X Terminal* for installation instructions.

11.4.3 Removing the Main Logic Board

This section explains how to remove a faulty main logic board from the system unit.

Note – Removing and replacing the main logic board is a drastic step to take. See Section 11.4.2 “Before Replacing the Main Logic Board” on page 11-21 for troubleshooting information.

To remove the main logic board:

1. **Prepare to work on the system as described in Chapter 6 “Power Off and On,” and in Chapter 7 “Internal Access.”**

Halt the system and verify that the power LED is not lit and that the fan is not running. Then open the system unit, detach all peripherals, and attach a wrist strap as described in Section 7.3 “Attaching the Wrist Strap” on page 7-3.



Caution – The AC power cord should remain attached between the system unit and an AC wall outlet. This connection provides the ground path necessary to protect internal system components from harmful static discharges. Inside the system unit, be sure the power supply wiring harness is connected to the main logic board to complete the ground.



Caution – Verify that the system power switch is in the Standby position. The green LED at the front of the system unit should not be lit and the fan should not be running. When the system power switch is in the Standby position, and the AC power cord remains connected to a power outlet, hazardous AC voltage is still present in the power supply primary. Do not attempt to service the power supply under these conditions. Disconnect the AC power cord prior to handling the power supply. When servicing any other system component, the AC power cord should remain connected and poses no safety hazard.

2. **Place an antistatic mat, shiny side down, next to the system unit.**

3. **Remove any SBus cards.**

See Section 11.1 “SBus Cards” on page 11-1 for removal procedures.

4. **Remove all DSIMMs from the main logic board.**

Note carefully the slot where each DSIMM resides so it may be installed in the same slot on the replacement main logic board. See Section 11.3.2 “Removing a DSIMM” on page 11-13, for removal procedures.

5. **Remove the optional VSIMM (if present).**

See Section 11.2.1 “Removing the VSIMM” on page 11-7, for removal procedures.

6. Disconnect all cables attached to the main logic board.

For connector locations, refer to FIGURE 11-12 and FIGURE 11-13 in Section 11.4 “Main Logic Board” on page 11-17.

- a. **Disconnect the 12-pin power supply cable from its mating connector by squeezing the clip at the end of the cable and pulling straight up.**
- b. **Disconnect the keyboard soft power-on cable from its connector next to the 12-pin power supply connector.**
- c. **Disconnect the LED/speaker cable from its mating connector on the main logic board.**
- d. **Disconnect the diskette drive data cable (if present) and the hard disk drive data cable from their connectors at the front of the main logic board.**

7. Remove the NVRAM chip.

See Section 11.5 “Nonvolatile RAM (NVRAM)” on page 11-31, for details. Place the NVRAM chip on the antistatic mat. Save the chip for installation on the replacement main logic board.

8. Remove the main logic board.

- a. **Pull the MLB (main logic board) extractor lever toward the front of the system unit to disconnect the main logic board from the system I/O board (see FIGURE 11-15).**
- b. **Raise the speaker assembly to allow removal of the main logic board (see FIGURE 11-16).**
- c. **Grasp the board by the SBus connectors with both hands. Tilt the board slightly to avoid the speaker assembly and lift it up and out of the system unit (see FIGURE 11-17). Avoid handling any of the delicate electronic components or touching any of the circuit board traces.**
- d. **Place the main logic board on an antistatic mat.**

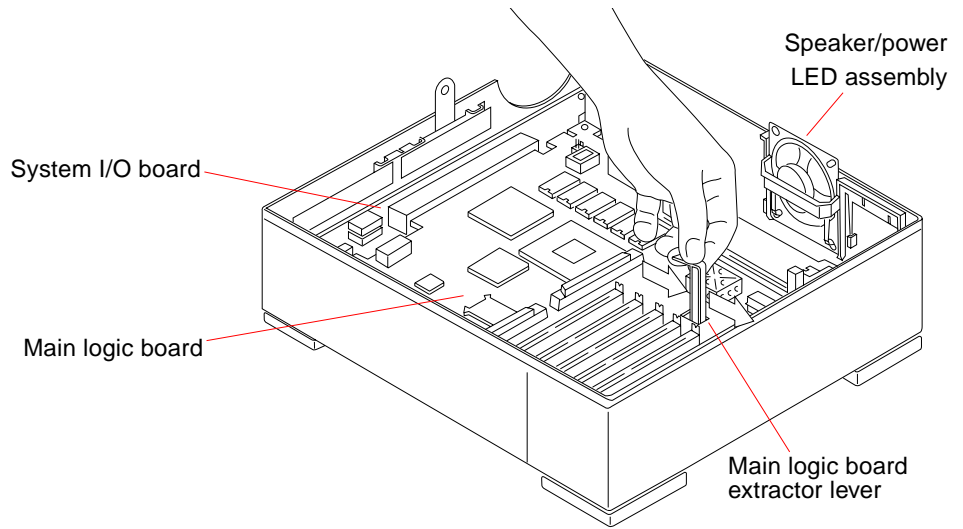

FIGURE 11-15 Extracting the Main Logic Board

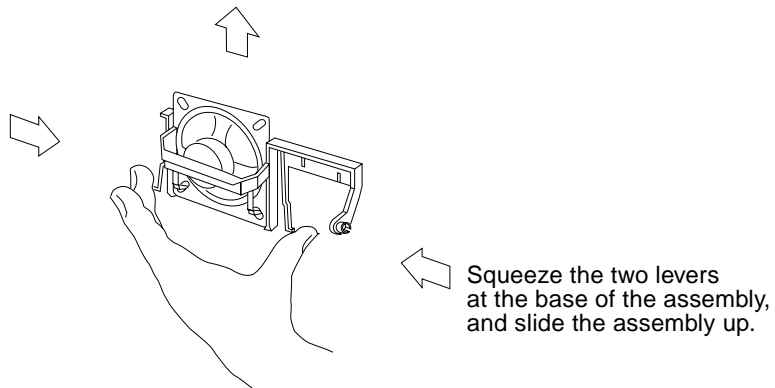

FIGURE 11-16 Raising the Speaker/LED Assembly

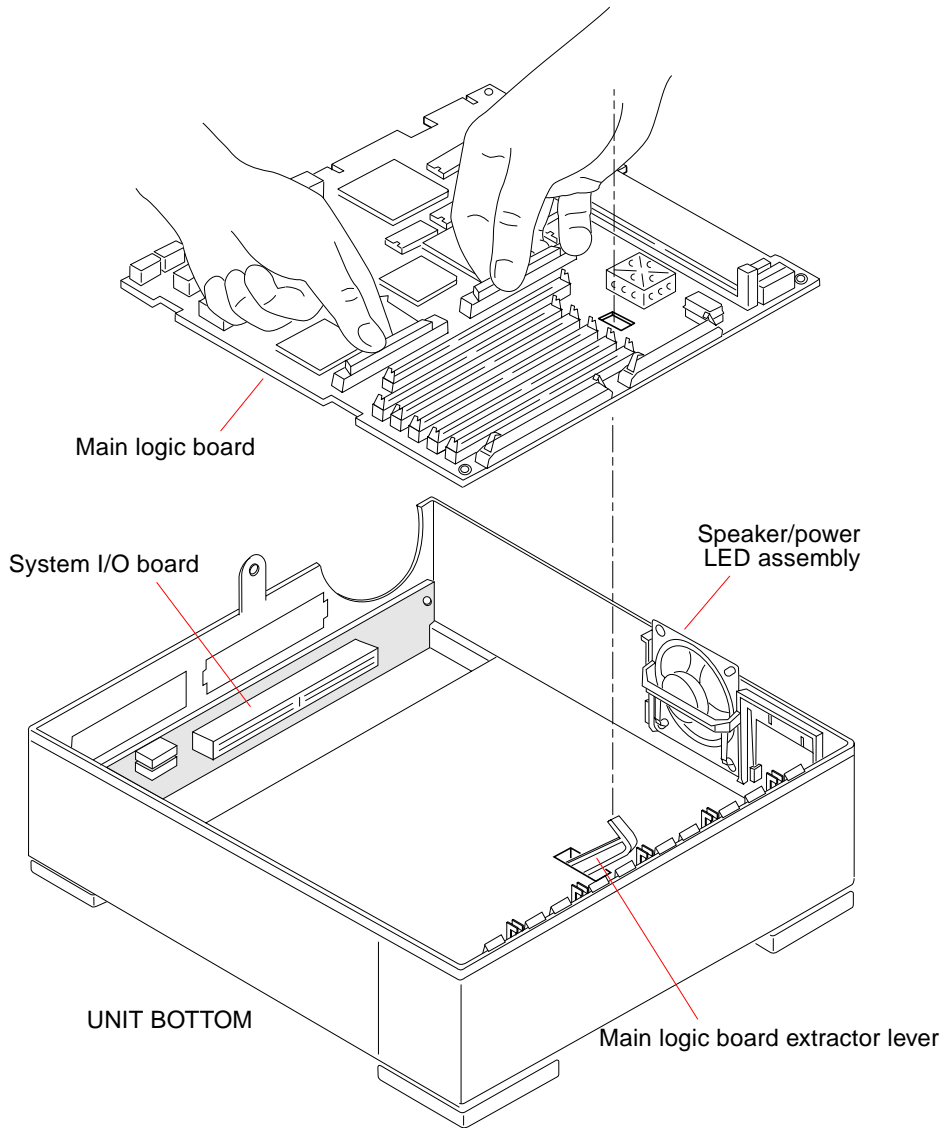

FIGURE 11-17 Removing and Replacing the Main Logic Board

11.4.4 Installing the New Main Logic Board

This section explains how to install a replacement main logic board in the system unit.

To install the main logic board:

1. Remove the defective main logic board as described in the previous section.

2. Install the NVRAM on the replacement main logic board.

Take the NVRAM chip you removed from the old main logic board and install it on the new main logic board. See Section 11.5 “Nonvolatile RAM (NVRAM)” on page 11-31, for details.

3. Install the DSIMMs.

Remove DSIMMs taken from the old main logic board and install them in the corresponding DSIMM slots of the new logic board. See Section 11.3.3 “Replacing a DSIMM” on page 11-15, for installation details.

4. Install the optional VSIMM (if applicable).

See Section 11.2.2 “Replacing the VSIMM” on page 11-9, for installation details.

5. Install the new main logic board.

- a. Grasp the board by the SBus connectors with both hands and guide the main logic board extractor lever through the rectangular cutout in the main logic board (see FIGURE 11-17). Avoid handling any of the delicate electronic components or touching any of the circuit board traces.**
- b. Tilt the board to avoid the speaker assembly and lower it onto the floor of the system unit.**
- c. Align the board’s edge connector with its mating connector on the system I/O board.**
- d. Push the main logic board extractor lever toward the rear of the system unit to plug the main logic board into the system I/O board (see FIGURE 11-18).**
- e. Lower the speaker assembly back to its original position.**

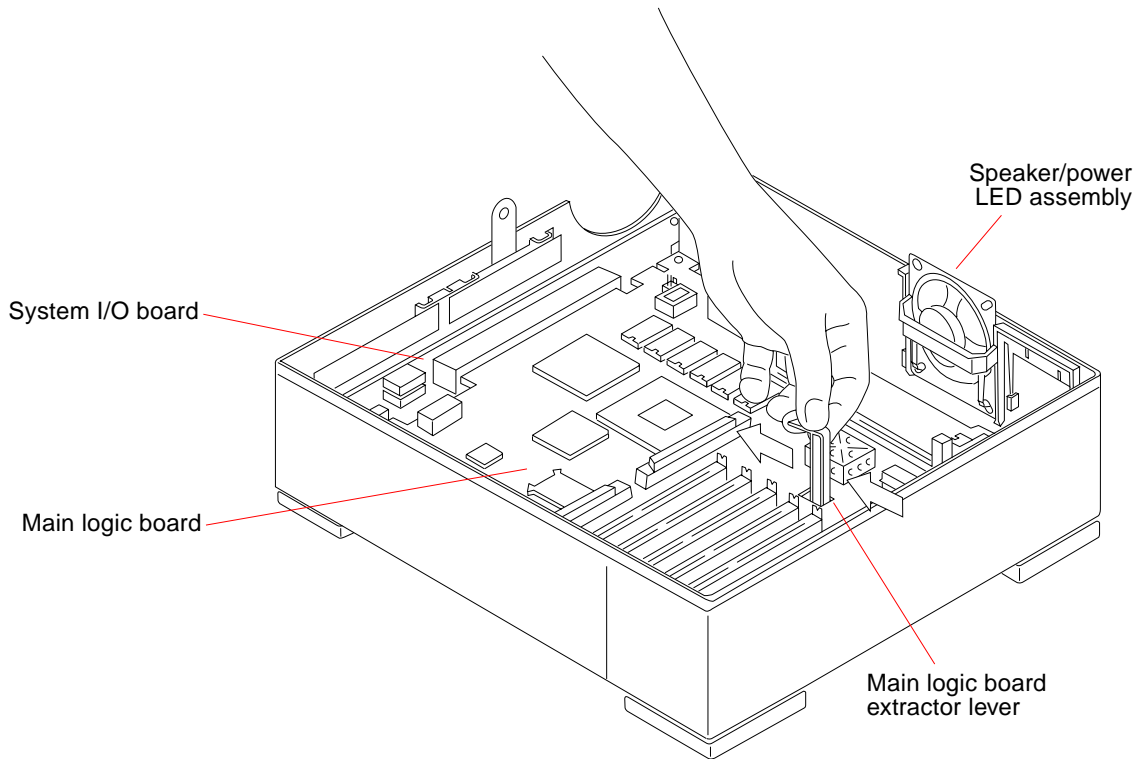

FIGURE 11-18 Plugging in the Main Logic Board

6. Reconnect all cables that attach to the main logic board.

Each connector is keyed to fit one way only. For connector locations, see FIGURE 11-12 and FIGURE 11-13.

- a. **Connect the 12-pin connector from the power supply harness to its mating connector on the main logic board.**
- b. **Connect the 3-pin connector from the power supply harness to the keyboard soft power-on connector on the main logic board.**
- c. **Connect the LED/speaker cable to its mating connector on the main logic board.**
- d. **Connect the diskette drive and hard disk drive data cables to their connectors at the front of the main logic board.**

7. Reinstall any SBus cards (if applicable).

See Section 11.1.2 “Replacing SBus Cards” on page 11-4 for installation details.

8. Refer to Chapter 7 “Internal Access” to perform the following procedures:

- Detaching the wrist strap
- Closing the system unit
- Reconnecting system components

9. Refer to Chapter 6 “Power Off and On” to turn the power on.

11.5 Nonvolatile RAM (NVRAM)

This section describes the removal and replacement procedures for the NVRAM chip. If you replace the main logic board, you must transfer the NVRAM chip from the faulty board to the replacement board.



Caution – The NVRAM chip is a delicate electronic component that is extremely sensitive to static electricity. Ordinary amounts of static from your clothes or work environment can destroy the NVRAM. Always wear a grounding strap when handling the NVRAM.

11.5.1 Removing the NVRAM

To remove the NVRAM:

1. Prepare to work on the system as described in Chapter 6 “Power Off and On, and in Chapter 7 “Internal Access.

Halt the system and verify that the power LED is not lit and that the fan is not running. Then open the system unit, detach all peripherals, and attach a wrist strap as described in Section 7.3 “Attaching the Wrist Strap” on page 7-3.



Caution – The AC power cord should remain attached between the system unit and an AC wall outlet. This connection provides the ground path necessary to protect internal system components from harmful static discharges. Inside the system unit, be sure the power supply wiring harness is connected to the main logic board to complete the ground.



Caution – Verify that the system power switch is in the Standby position. The green LED at the front of the system unit should not be lit and the fan should not be running. When the system power switch is in the Standby position, and the AC power cord remains connected to a power outlet, hazardous AC voltage is still present in the power supply primary. Do not attempt to service the power supply

under these conditions. Disconnect the AC power cord prior to handling the power supply. When servicing any other system component, the AC power cord should remain connected and poses no safety hazard.

2. Locate the NVRAM chip carrier on the main logic board.

See FIGURE 11-19.

3. Hold the NVRAM chip carrier on both ends, and lift the chip straight up.

Gently wiggle the carrier as necessary (see FIGURE 11-20).

4. Place it on the antistatic mat.

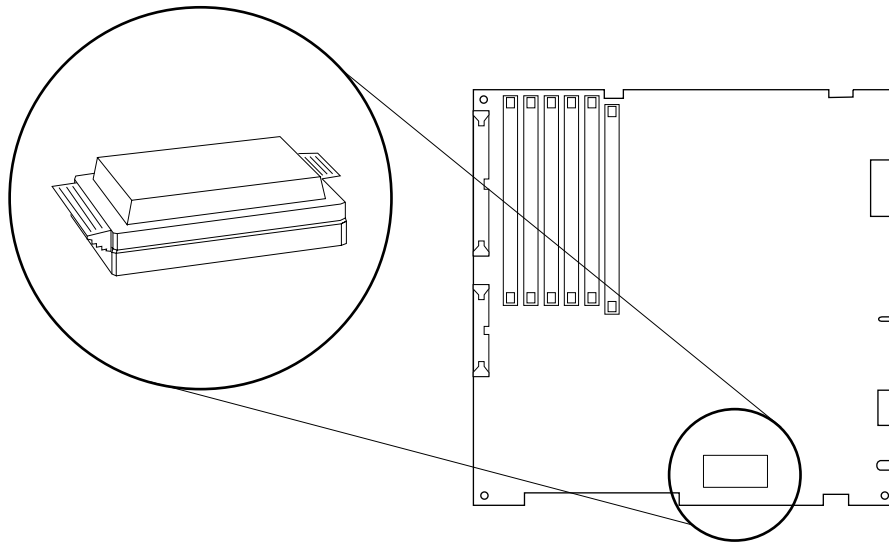

FIGURE 11-19 Locating the NVRAM

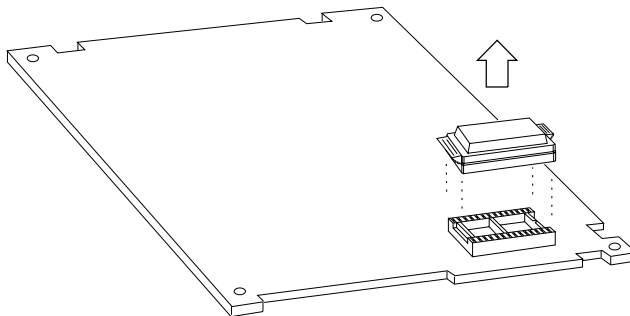

FIGURE 11-20 Removing the NVRAM

11.5.2 Replacing the NVRAM

To install the NVRAM on the main logic board:

1. Hold the NVRAM chip on both sides of the carrier.
2. Carefully align the pins and insert the NVRAM chip into its socket.
The carrier is keyed so the NVRAM can be installed only one way.
3. Push down on the NVRAM chip until it is fully seated in its socket.
4. Refer to Chapter 7 “Internal Access to perform the following procedures:
 - Detaching the wrist strap
 - Closing the system unit
 - Reconnecting system components
5. Refer to Chapter 6 “Power Off and On to turn the power on.

11.6 SPARCstation LX ISDN Jumper Settings

The SPARCstation LX is configured for ISDN support. Shown in FIGURE 11-21 are the default jumper settings for the main logic board addresses J1801 and J1802, respectively. TABLE 11-3 fully describes these jumper settings.

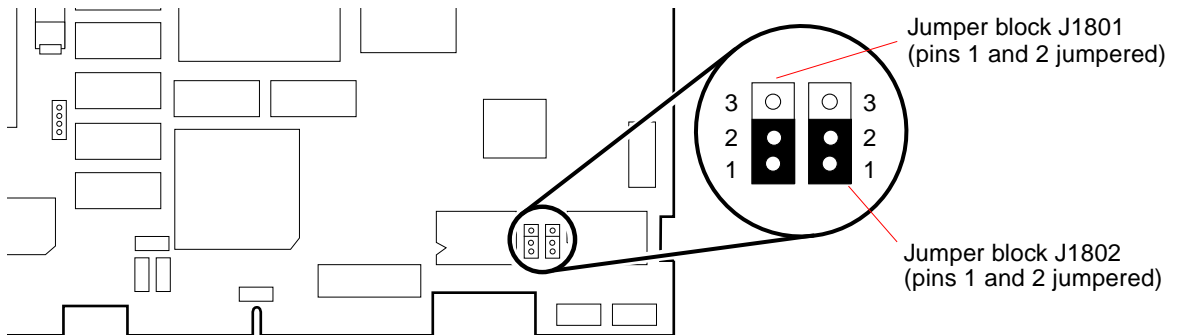

FIGURE 11-21 Default SPARCstation LX ISDN Jumper Settings

The SPARCstation LX system board is delivered with the jumpers set for termination on the system board. For more information about setting these jumpers, the *Sun ISDN-BRI/SBI Hardware Configuration Guide*.

TABLE 11-3 SPARCstation LX ISDN Jumper Settings

Address	Jumper Pins	Setting	Description
J1801	1, 2	Jumpered	ISDN termination is on the system board (default).
	2, 3	Jumpered	ISDN termination is assumed set at the ISDN jack in the wall.
	1, 2, 3	Not jumpered	ISDN termination is assumed set at the ISDN jack in the wall.
J1802	1, 2	Jumpered	ISDN termination is on the system board (default).
	2, 3	Jumpered	ISDN termination is assumed set at the ISDN jack in the wall.
	1, 2, 3	Not jumpered	ISDN termination is assumed set at the ISDN jack in the wall.

Illustrated Parts Breakdown

This chapter provides an illustrated parts breakdown (IPB) of the major parts that comprise the SPARCclassic, SPARCclassic X, and SPARCstation LX systems, and a list of customer replaceable units and their part numbers.

- Section 12.1 “Illustrations of Selected CRUs”
- Section 12.2 “Replacement Part List”

Note – Remember that diskette drive and hard drive parts do not apply to the SPARCclassic X terminal.

12.1 Illustrations of Selected CRUs

FIGURE 12-1 through FIGURE 12-3 show exploded view illustrations of the SPARCclassic/SPARCstation LX system unit.

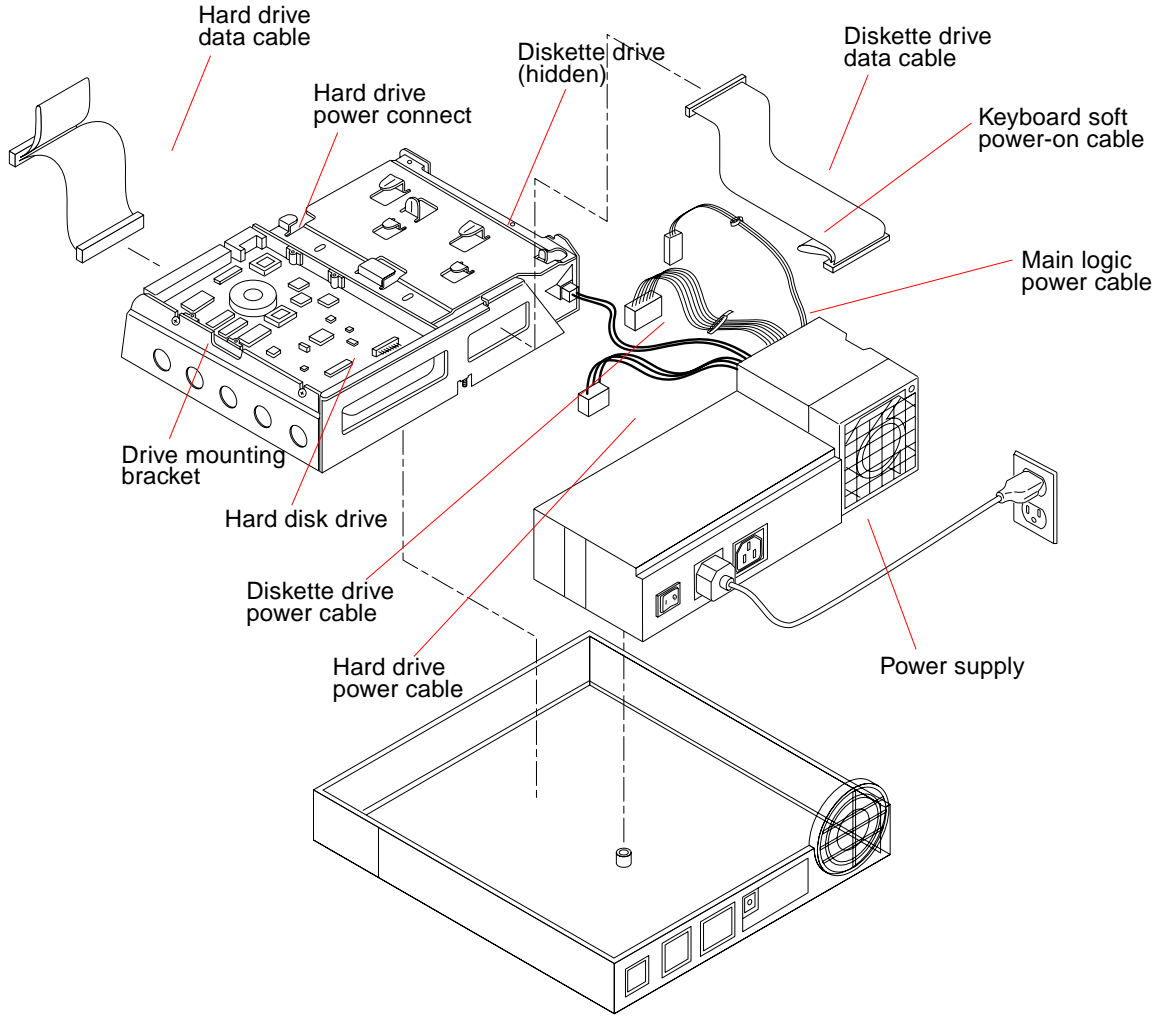

FIGURE 12-1 Exploded View of the Unit Top

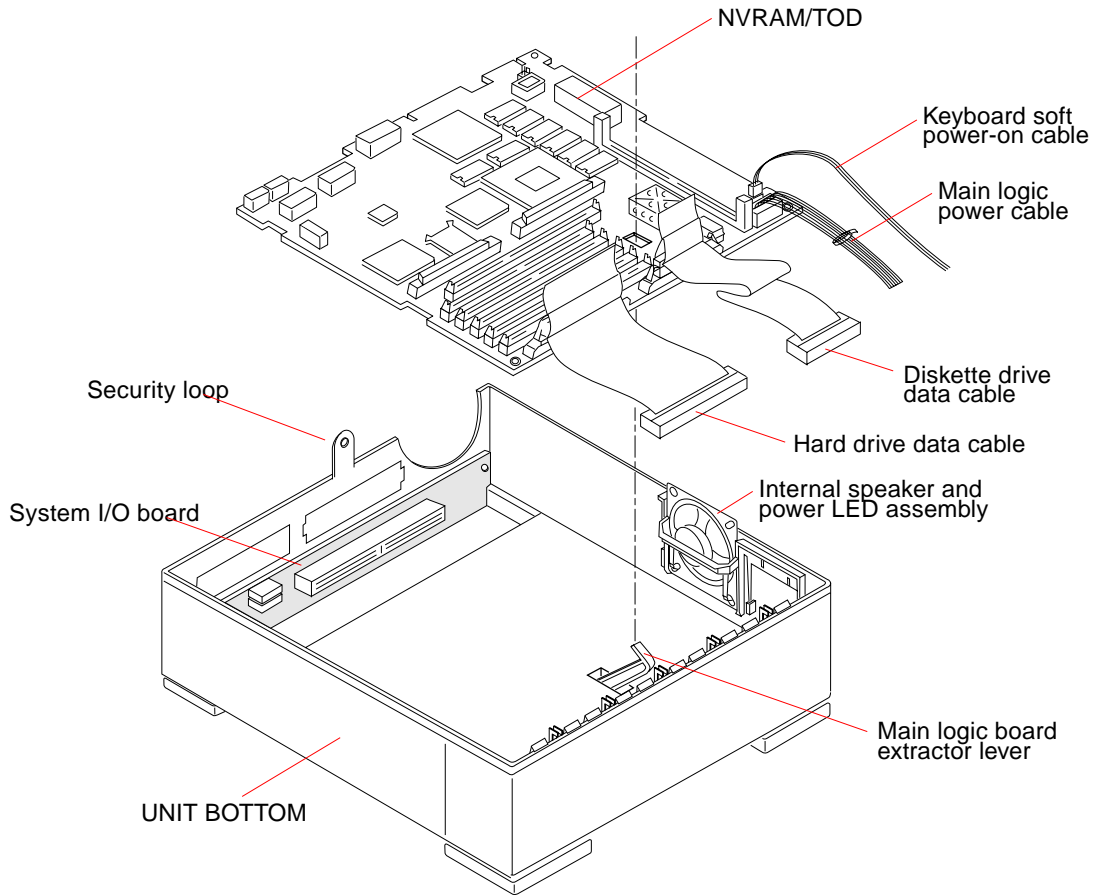

FIGURE 12-2 Exploded View of the Unit Bottom

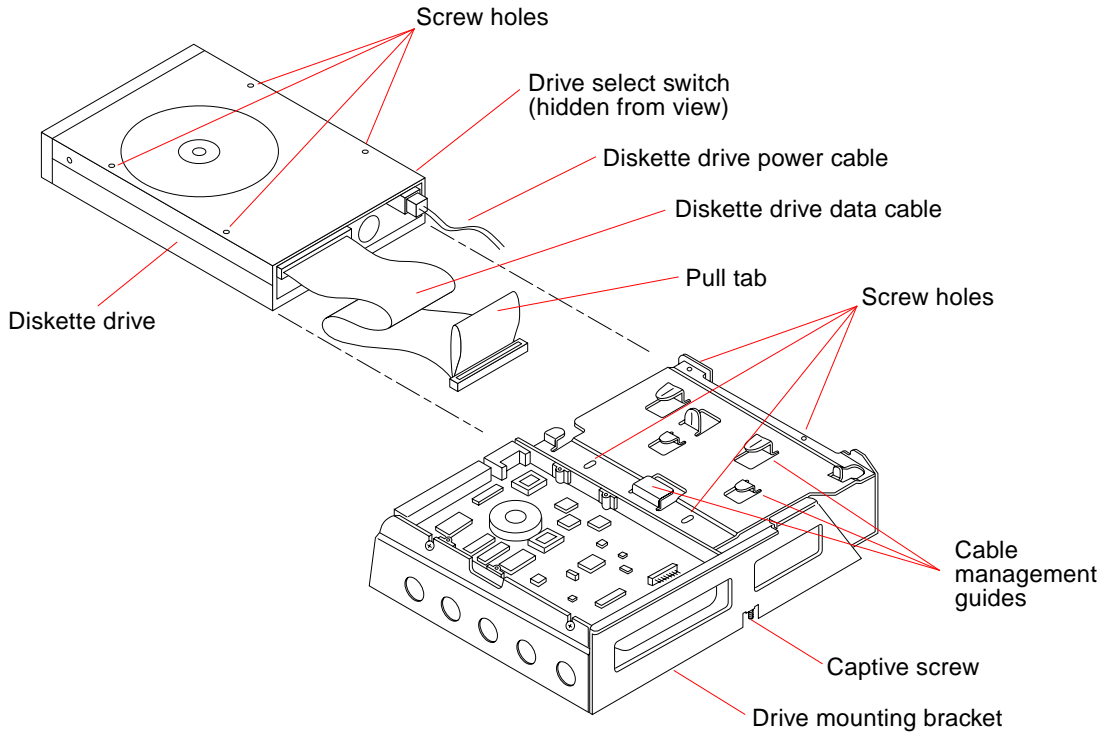

FIGURE 12-3 Exploded View of the Disk Drive Mounting Bracket

12.2 Replacement Part List

TABLE 12-1 provides the part numbers for customer replaceable units, TABLE 12-2 provides part numbers for miscellaneous items, and TABLE 12-3 part numbers for related documentation.

Note – Although the part numbers are correct as of the publication date of this document, they are subject to change. Consult your authorized Sun sales representative or service provider to confirm part numbers before you order new or replacement parts.

TABLE 12-1 Part Number List—Customer Replaceable Units

Item	Description	Sun Part No.
1	207-Mbyte Internal Disk Drive	370-1417
2	424-Mbyte Internal Disk Drive	370-1392
3	535-Mbyte Internal Disk	370-1424
4	1.0-Gbyte Internal Disk Drive	370-1546
5	Tri-density Floppy Drive	370-1419
6	70-Watt Power Supply	300-1101
7	System I/O Board	501-2269
8	Internal Speaker/Power LED Assembly	540-2233
9	Main Logic Board (0 Mbyte)—SPARCclassic	501-2262
10	Main Logic Board (0 Mbyte)—SPARCstation LX	501-2474
11	Main Logic Board (4 Mbyte)—SPARCclassic X	501-2079
12	Main Logic Board (8 Mbyte)—SPARCclassic X	501-2313
13	Upgrade (SPARCclassic X 4-Mbyte to Classic 16-Mbyte)	556-1774
14	Upgrade (SPARCclassic X 8-Mbyte to Classic 16-Mbyte)	556-1775
15	1-Mbyte DSIMM Module	501-2289
16	2-Mbyte DSIMM Module	501-2433
17	4-Mbyte DSIMM Module	501-1991
18	16-Mbyte DSIMM Module	501-2059
19	1-Mbyte VSIMM Module	501-2061
20	NVRAM/TOD	525-1203
21	NVRAM/TOD (SPARCclassic X)	525-1343
22	Diskette Drive Data Cable (Internal)	530-1643
23	Hard Drive Data Cable (Internal)	530-1678
24	13W3 Video Cable	530-1870
25	SCSI II Cable	530-1793

TABLE 12-1 Part Number List—Customer Replaceable Units *(Continued)*

Item	Description	Sun Part No.
26	AUI/Audio Adapter Cable	530-1856
27	AUI Adapter Cable	530-2021
28	Serial Interface Y-Cable	530-1869
29	SunMicrophone	370-1414
30	ISDN Cable (4.0 m)	530-1871
31	Twisted-Pair Ethernet Cable	530-1871
32	Keyboard Cable	530-1442
33	Type-4 Mouse/Type-4 Pad	365-1059
34	Type-5 Mouse/Type-5 Pad	370-1398
35	U.S. Type-5 Keyboard	320-1072
36	U.S. UNIX Type-5 Keyboard	320-1073
37	French Type-5 Keyboard	320-1074
38	Danish Type-5 Keyboard	320-1075
39	German Type-5 Keyboard	320-1076
40	Italian Type-5 Keyboard	320-1077
41	Holland/Dutch Type-5 Keyboard	320-1078
42	Norwegian Type-5 Keyboard	320-1079
43	Portuguese Type-5 Keyboard	320-1080
44	Spanish Type-5 Keyboard	320-1081
45	Swedish/French Type-5 Keyboard	320-1082
46	Swiss/French Type-5 Keyboard	320-1083
47	Swiss/German Type-5 Keyboard	320-1084
48	U.K. Type-5 Keyboard	320-1085
49	Korean Type-5 Keyboard	320-1086
50	Taiwan Type-5 Keyboard	320-1087
51	Nihon-Go Type-5 Keyboard	320-1088
52	Finnish Type-5 Keyboard	320-1089
53	19" Grayscale Monitor	365-1154
54	15" SVGA Monitor	365-1286
55	16" Mid-range Color Monitor	365-1151

TABLE 12-1 Part Number List—Customer Replaceable Units *(Continued)*

Item	Description	Sun Part No.
56	16" Premium Color Monitor	365-1159
57	19" Color Monitor	365-1167
58	Speaker Box	540-2220

TABLE 12-2 Part Number List—Miscellaneous Items

Item	Description	Sun Part No.
1	Wrist Strap	250-1007
2	Vertical Stand (side piece)	330-1455
3	Vertical Stand (base piece)	330-1458
4	Antistatic Mat with Sun Logo	250-1088
5	Disposable Antistatic Mat	330-1145
6	ISDN Enabling Kit	595-2459
7	Disk Drive Bracket Shoulder Screw	240-2145

TABLE 12-3 Part Number List—Related Hardware Documentation

Item	Description	Sun Part No.
1	<i>Desktop Storage Pack Installation & Operation Manual</i>	800-6316
2	<i>Desktop Storage Module Installation & User's Guide</i>	800-7235
3	<i>Desktop SPARC Hardware Owner's Guide</i>	801-2175
4	<i>Desktop SPARC Hardware Product Notes</i>	801-2179
5	<i>Sundiag User's Guide</i>	801-5319
6	<i>Sundiag User's Guide—Addendum for SMCC Hardware</i>	801-5497
7	<i>Open Boot Command Reference</i>	800-6076
8	<i>Open Boot Command Summary</i>	800-5675
9	<i>SPARCstation LX Hardware Setup Instructions</i>	801-2177
10	<i>SPARCclassic Hardware Setup Instructions</i>	801-2210
11	<i>SPARCclassic X Terminal Hardware Setup Instructions</i>	801-4250

TABLE 12-3 Part Number List—Related Hardware Documentation (*Continued*)

Item	Description	Sun Part No.
12	<i>SPARCclassic X Upgrade Guide</i>	801-4721
13	<i>Installing SPARCclassic/SPARCclassic X/SPARCstation LX SIMMs</i>	801-2211
14	<i>Sun ISDN-BRI/SBIH Hardware Configuration Guide</i>	800-6863

System Specifications

This appendix contains system specifications, including input power requirements, environmental requirements, physical specifications, and regulatory compliance information. All specifications are applicable to both SPARCclassic and SPARCstation LX systems. Not all specifications will be applicable to the SPARCclassic X terminal, which does not come equipped with a diskette drive or hard disk drive.

- Section A.1 “Input Power Requirements”
- Section A.2 “Environmental Requirements”
- Section A.3 “Physical Specifications”
- Section A.4 “Regulatory Compliance”

A.1 Input Power Requirements

TABLE A-1 lists the input power requirements for the system unit.

TABLE A-1 Input Power Requirements and Power Dissipation

Parameter	Specification
Nominal Frequencies	50 Hz or 60 Hz nominal
Nominal Voltage Range	100-120 Vac or 200-240 Vac (100-240 Vac Auto)
Maximum Current AC RMS ^{1*}	2 A @ 100-120 Vac, 1 A @ 200-240 Vac
AC Operating Range	87-264 Vrms, 47-63 Hz
Maximum VA Rating	153.8 VA
Maximum Power Consumption	107.7 Watts
Maximum Heat Output	367.5 BTU/hr

1. Maximum input current with accessory connected to accessory outlet is 6A

A.2 Environmental Requirements

TABLE A-2 lists the environmental requirements for both operating and non-operating environments.

TABLE A-2 Environmental Requirements

Operating Environment:

Temperature	10 to 40°C (50 to 104°F)
Humidity	20 to 80% relative noncondensing at 40°C (104°F)
Wet Bulb	25°C (77°F) maximum
Altitude	0 to 3048 m (0 to 10,000 ft)
Vibration	5-22 Hz, 0.01 inches p-p; 22-500 Hz, 0.25 g p-p
Shock	5 g pk, 10 msec 1/2 sine wave

Non-Operating Environment:

Temperature	20 to 75°C (-4 to 167°F)
Wet Bulb	46°C (115°F) maximum
Vibration	5-22 Hz, 0.02 inches p-p; 22-500 Hz, 0.5 g p-p
Shock	5 g pk, 10 msec 1/2 sine wave

A.3 Physical Specifications

TABLE A-3 lists the physical specifications for the system unit, keyboard, and optical mouse.

TABLE A-3 Physical Specifications

Component	Height inches (mm)	Width inches (mm)	Depth inches (mm)	Net Weight lbs (kg)
System Unit	4.6 (118)	9.6 (245)	10.4 (264)	11.0 (4.95)
Keyboard, Type 5	1.7 (44)	20.1 (510)	7.2 (182)	3.5 (1.6)
Mouse	2.0 (50)	4.0 (100)	3.0 (80)	0.3 (0.14)

A.4 Regulatory Compliance

TABLE A-4 lists regulatory compliance information.

TABLE A-4 Regulatory Compliance Information

Product Safety	EMI	Ergonomics	X-Ray Emissions
UL 1950	FCC Class B	German Federal	DHHS, PTB
CSA C22.2 No. 950	VDE Class B	Republic ZH 1/618	
IEC 950 NEMKO CB	DOC Class B	ISO 9241	
EN60950-TÜV	VCCI Class 2		
EN41003-TÜV			

System Connectors

This appendix contains pinouts and illustrations of the various system connectors. The following connectors are described.

- Section B.1 “Attachment Unit Interface (AUI) Connector”
- Section B.2 “Twisted-Pair Ethernet Connector”
- Section B.3 “ISDN Terminal Endpoint Connector”
- Section B.4 “ISDN Network Termination Connector”
- Section B.5 “Keyboard/Mouse Connector”
- Section B.6 “SCSI Connector (External)”
- Section B.7 “Serial Connector”
- Section B.8 “Parallel Connector”
- Section B.9 “13W3 Video Connector”
- Section B.10 “Audio Ports and Audio Module”
- Section B.12 “SCSI Connector (Internal)”
- Section B.13 “Diskette Drive Connector (Internal)”
- Section B.14 “SBUS Connector (Internal)”
- Section B.15 “Power Connector (Internal)”

B.1 Attachment Unit Interface (AUI) Connector

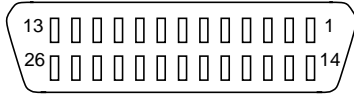

FIGURE B-1 Attachment Unit Interface (AUI) Connector

TABLE B-1 Pinout for Attachment Unit Interface (AUI) Connector

Pin	Description	Pin	Description
1	AUI_DO_L	14	AUI_DO
2	AUI_DI	15	AUI_DI_L
3	AUI_CI_L	16	AUI_CI
4	ENET_PWR	17	GND
5	EMCTL	18	RESET_SENSE_L
6	CHIDX	19	CHIDR
7	CHI_CLK	20	CHIDFS
8	CODFS	21	CODCK
9	N/C	22	N/C
10	Vcc	23	GND
11	Vcc	24	GND
12	Codec_PWR_DN_L	25	MIDI_OUT
13	MIDI_IN	26	MIDI_IN_L

B.2 Twisted-Pair Ethernet Connector

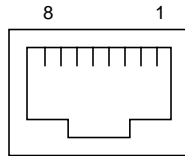

FIGURE B-2 Twisted-Pair Ethernet Connector

TABLE B-2 Pinout for Twisted-Pair Ethernet Connector

Pin	Description	Pin	Description
1	Transmit Data +	5	N/C
2	Transmit Data -	6	Receive Data -
3	Receive Data +	7	N/C
4	N/C	8	N/C

B.3 ISDN Terminal Endpoint Connector

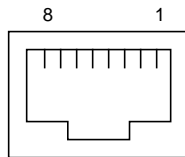

FIGURE B-3 ISDN Terminal Endpoint Connector

TABLE B-3 Pinout for ISDN Terminal Endpoint Connector

Pin	Description	Pin	Description
1	PS1	5	Receive Data -
2	PS1-	6	Transmit Data -
3	Transmit Data +	7	PS2-
4	Receive Data +	8	PS2

B.4 ISDN Network Termination Connector

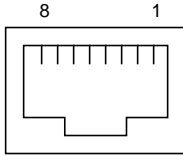

FIGURE B-4 ISDN Network Termination Connector

TABLE B-4 Pinout for ISDN Network Termination Connector

Pin	Description	Pin	Description
1	PS1	5	Transmit Data -
2	PS1-	6	Receive Data -
3	Receive Data +	7	PS2-
4	Transmit Data +	8	PS2

Note – The +5 Volt line is fuse-protected.

B.5 Keyboard/Mouse Connector

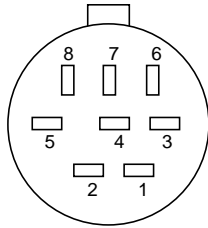

FIGURE B-5 Keyboard/Mouse Connector

TABLE B-5 Pinout for Keyboard/Mouse Connector

Pin	Description	Pin	Description
1	Ground	5	Keyboard Out
2	Ground	6	Keyboard In
3	+5 Vdc	7	KBD_PWR_ON_L
4	Mouse In	8	+5 Vdc

Note – All signals are standard TTL levels. The +5V supply is fuse-protected.

B.6 SCSI Connector (External)

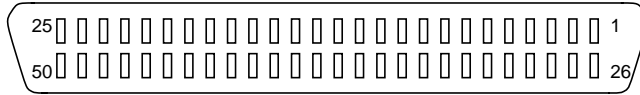

FIGURE B-6 External SCSI Connector

TABLE B-6 Pinout for External SCSI Connector

Pin	Description	Pin	Description
1	Ground	26	sd0*
2	Ground	27	sd1*
3	Ground	28	sd2*
4	Ground	29	sd3*
5	Ground	30	sd4*
6	Ground	31	sd5*
7	Ground	32	sd6*
8	Ground	33	sd7*
9	Ground	34	sdp*
10	Ground	35	Ground
11	Ground	36	Ground
12	N/C	37	N/C
13	N/C	38	TermPWR
14	N/C	39	N/C
15	Ground	40	Ground
16	Ground	41	atn*
17	Ground	42	Ground
18	Ground	43	bsy*
19	Ground	44	ack*
20	Ground	45	rst*
21	Ground	46	msg*
22	Ground	47	sel*

TABLE B-6 Pinout for External SCSI Connector (Continued)

Pin	Description	Pin	Description
23	Ground	48	cd*
24	Ground	49	req*
25	Ground	50	io*

Note – Pin 38 is +5V, fused and supplied by a schottkey diode.

B.7 Serial Connector

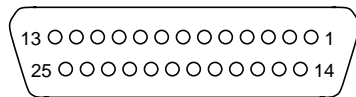

FIGURE B-7 Serial Connector

TABLE B-7 Pinout for Serial Connector

Pin	Description	Pin	Description
1	N/C	14	B Transmit Data
2	A Transmit Data	15	A Transmit Clock (DCE source)
3	A Receive Data	16	B Receive Data
4	A Request to Send	17	A Receive Clock
5	A Clear to Send	18	B Transmit Clock (DCE source)
6	A Data Set Ready	19	B Request to Send
7	Signal Ground	20	A Data Terminal Ready
8	A Carrier Detect	21	N/C
9	N/C	22	N/C
10	N/C	23	N/C
11	B Data Terminal Ready	24	A Transmit Clock (DTE source)
12	B Carrier Detect	25	B Transmit Clock (DTE source)
13	B Clear to Send		

B.8 Parallel Connector

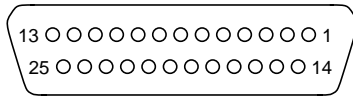

FIGURE B-8 Parallel Connector

TABLE B-8 Pinout for Parallel Connector

Pin	Description	Pin	Description
1	Strobe	14	AutoFxDt
2	Data 0 (LSB)	15	Error
3	Data 1	16	Init
4	Data 2	17	SlctIn
5	Data 3	18	Ground
6	Data 4	19	Ground
7	Data 5	20	Ground
8	Data 6	21	Ground
9	Data 7	22	Ground
10	Ack	23	Ground
11	Busy	24	Ground
12	PE	25	Ground
13	Slct		

B.9 13W3 Video Connector

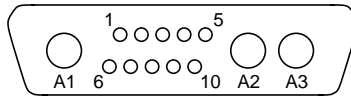

FIGURE B-9 13W3 Video Connector

TABLE B-9 Pinout for 13W3 Video Connector

Pin	Description	Pin	Description
A1	Video-Red	5	Composite Sync
A2	Video-Green	6	Ground
A3	Video-Blue	7	Ground
1	Ground	8	Sense(1)
2	Ground	9	Sense(0)
3	Sense(2)	10	Ground
4	Ground		

B.10 Audio Ports and Audio Module

B.10.1 Audio Ports

The audio ports are on all models with the SPARCclassic/SPARCclassic X/SPARCstation LX system board (on the SPARCclassic X terminal the ports are covered and inactive). Section B.11 “Signals for the Audio Ports gives the signals for the audio ports.

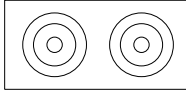

FIGURE B-10 Audio Ports

TABLE B-10 Audio Ports

Line-Out	Line-In
Left Channel	Left Channel
Right Channel	Right Channel
Return	Return

B.11 Signals for the Audio Ports

B.11.1 Audio Line-Out Connector



FIGURE B-11 Audio Line-out Connector

This connector is used to connect the system audio output to a stereophonic amplifier and external loudspeakers.

B.11.2 Audio Line-In Connector



FIGURE B-12 Audio Line-in Connector

This connector is used to connect external sound sources such as a compact disc player or cassette tape player to the system.

B.12 SCSI Connector (Internal)

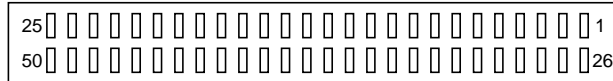

FIGURE B-13 Internal SCSI Connector

TABLE B-11 Pinout for Internal SCSI Connector

Pin	Description	Pin	Description
1	Ground	26	+5 VDC
2	sd0*	27	N/C
3	Ground	28	N/C
4	sd1*	29	Ground
5	Ground	30	Ground
6	sd2*	31	Ground
7	Ground	32	atn*
8	sd3*	33	Ground
9	Ground	34	N/C
10	sd4*	35	Ground
11	Ground	36	bsy*
12	sd5*	37	Ground
13	Ground	38	ack*
14	sd6*	39	Ground
15	Ground	40	rst*
16	sd7*	41	Ground
17	Ground	42	msg*
18	sdp*	43	Ground
19	Ground	44	sel*
20	Ground	45	Ground

TABLE B-11 Pinout for Internal SCSI Connector (Continued)

Pin	Description	Pin	Description
21	Ground	46	cd*
22	Ground	47	Ground
23	N/C	48	reg*
24	N/C	49	Ground
25	N/C	50	io*

B.13 Diskette Drive Connector (Internal)

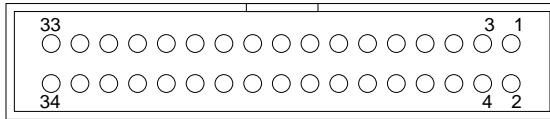
**FIGURE B-14** Diskette Drive Connector**TABLE B-12** Pinout for Diskette Drive Connector

Pin	Description	Pin	Description
1	eject	18	direction
2	N/C	19	Ground
3	Ground	20	step
4	N/C	21	Ground
5	Ground	22	write data
6	N/C	23	Ground
7	Ground	24	write gate
8	Index	25	Ground
9	Ground	26	track 0
10	drive select 0	27	Ground
11	Ground	28	write protect
12	N/C	29	Ground
13	Ground	30	read data

TABLE B-12 Pinout for Diskette Drive Connector (*Continued*)

Pin	Description	Pin	Description
14	N/C	31	Ground
15	Ground	32	hd select
16	motor	33	Ground
17	Ground	34	disk change

B.14 SBus Connector (Internal)

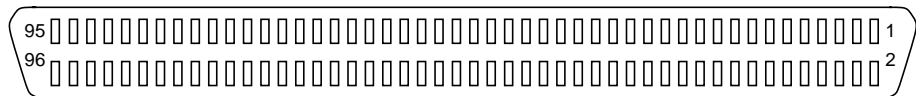

FIGURE B-15 SBus Connector

TABLE B-13 Pinout for SBus Connector

Pin	Description	Pin	Description	Pin	Description	Pin	Description
1	Ground	25	sb_d(31)	49	sb_clk	73	sb_d(30)
2	sb_br*	26	sb_siz(0)	50	sb_bg*	74	sb_siz(1)
3	sb_sel*	27	sb_siz(2)	51	sb_as*	75	sb_rd
4	sb_irq1*	28	sb_irq7*	52	Ground	76	Ground
5	sb_d(0)	29	sb_a(0)	53	sb_d(1)	77	sb_a(1)
6	sb_d(2)	30	sb_a(2)	54	sb_d(3)	78	sb_a(3)
7	sb_d(4)	31	sb_a(4)	55	sb_d(5)	79	sb_a(5)
8	sb_irq2*	32	sb_merr*	56	+5 VDC	80	+5 VDC
9	sb_d(6)	33	sb_a(6)	57	sb_d(7)	81	sb_a(7)
10	sb_d(8)	34	sb_a(8)	58	sb_d(9)	82	sb_a(9)
11	sb_d(10)	35	sb_a(10)	59	sb_d(11)	83	sb_a(11)
12	sb_irq3*	36	sb_err*	60	Ground	84	Ground
13	sb_d(12)	37	sb_pa(12)	61	sb_d(13)	85	sb_pa(13)
14	sb_d(14)	38	sb_pa(14)	62	sb_d(15)	86	sb_pa(15)
15	sb_d(16)	39	sb_pa(16)	63	sb_d(17)	87	sb_pa(17)

TABLE B-13 Pinout for SBus Connector (Continued)

Pin	Description	Pin	Description	Pin	Description	Pin	Description
16	sb_irq4*	40	sb_ack8*	64	+5 VDC	88	+5 VDC
17	sb_d(19)	41	sb_pa(18)	65	sb_d(18)	89	sb_pa(19)
18	sb_d(21)	42	sb_pa(20)	66	sb_d(20)	90	sb_pa(21)
19	sb_d(23)	43	sb_pa(22)	67	sb_d(22)	91	sb_pa(23)
20	sb_irq5*	44	sb_ack32*	68	Ground	92	Ground
21	sb_d(25)	45	sb_pa(24)	69	sb_d(24)	93	sb_pa(25)
22	sb_d(27)	46	sb_pa(26)	70	sb_d(26)	94	sb_pa(27)
23	sb_d(29)	47	N.C.	71	sb_d(28)	95	sb_reset*
24	sb_irq6*	48	-12 VDC	72	+5 VDC	96	+12 VDC

B.15 Power Connector (Internal)



FIGURE B-16 Power Connector

TABLE B-14 Pinout for Power Connector

Pin	Description	Pin	Description
1	+5 Vdc	7	+5 Vdc
2	+5 Vdc	8	+5 Vdc
3	Ground	9	Ground
4	Ground	10	Ground
5	+12 Vdc	11	+12 Vdc
6	POK	12	-12 Vdc

On-Board Diagnostics

This appendix explains On-Board Diagnostic tests. The following topics and tests are described.

- Section C.1 “Running the On-Board Diagnostics”
- Section C.1.1 “Test <alias name>, Test <device path>”
- Section C.1.2 “Test-all”
- Section C.1.3 “Watch-clock”
- Section C.1.4 “Watch-net, Watch-aui, Watch-tpe and Watch-net-all”
- Section C.1.5 “Probe-scsi, Probe-scsi-all”
- Section C.1.6 “Test-memory”
- Section C.2 “Returning to the Monitor Prompt”

You have access to a number of additional tests in the boot PROM called On-Board Diagnostics. To invoke these tests, you must enter the Forth Toolkit.



Caution – To run the On-Board Diagnostics, you must halt the system in an orderly manner. When the operating system or any other standalone program has already booted, do not press Stop-a to halt the system. Abruptly aborting program execution may cause damage to data files.

C.1 Running the On-Board Diagnostics

1. Save all your work and quit all applications.

Consult your software documentation for instructions on ending a work session and saving your files.

2. Return to the operating system environment.

If you are in a windowing environment, exit from it and wait for the operating system prompt to appear. See the documentation supplied with your windowing system.

3. Halt the operating system.

See the documentation supplied with your operating system for instructions on how to halt it.

For example, if you are using the Solaris 2.x operating system:

a. At the system prompt, type `su` and press Return.

b. Type your superuser password and press Return.

4. To inform other system users of your intentions, and to then halt the system use Step c.

5. To halt the system immediately, continue with Step d.

a. Type `/usr/sbin/shutdown +5` and press Return.

The example above uses 5 minutes for a warning period to other system users. Use appropriately chosen switch settings to inform other system users of your intentions (see `shutdown(1)`). Continue with Step 4.

b. Type `/usr/sbin/init 0` and press Return.

For example, to halt the system immediately type:

```
nevada% su
Password: welcome(Password does not appear on screen.)
nevada# /usr/sbin/init 0
```

See the documentation supplied with your operating system for instructions on how to halt it. The system synchronizes the file systems and brings you to either the `>` or `ok` prompt.

If you see the `ok` prompt, *skip ahead to step 5; otherwise, continue with step 4.*

6. Enter `n` at the `>` prompt to get to the `ok` prompt.

7. Enter `reset` at the `ok` prompt.

8. When you see the system banner, press Stop-a to access the Forth Toolkit.

9. Enter `help diag` at the `ok` prompt to get a list of tests that comprise the On-Board Diagnostics.

10. Enter the name of the test you wish to execute.

The following example shows a list of On-Board Diagnostic tests.

Note – There are no “SCSI device” or “floppy disk drive” tests for the SPARCclassic X terminal.

```
ok help diag
  Category: Diag (diagnostic routines)
test  device-specifier ( -- ) run selftest method for specified device
  Examples:
    test /memory      - test memory
    test /iommu/sbus/ledma/le      - test net
    test floppy       - test floppy disk drive
    test net          - test net (device-specifier is an alias)
    test scsi         - test scsi(device-specifier is an alias)
watch-clock          (-- ) show ticks of real-time clock
watch-net            (-- ) - monitor broadcast packets using auto-selected
interface
watch-aui            (-- ) - monitor broadcast packets using AUI interface
watch-tpe            (-- ) - monitor broadcast packets using TPE interface
watch-net-all       (-- ) - monitor broadcast packets on all net interfaces
probe-scsi           (-- ) - show attached SCSI devices
probe-scsi-all      (-- ) - show attached SCSI devices for all host adapters
test-all            (-- ) - execute test for all devices with selftest method
test-memory          (-- ) - test all memory if diag-switch? is true, otherwise
test memory
                                specified by selftest-#megs
```

C.1.1 Test <alias name>, Test <device path>

The `test` command, combined with a device alias or device path name, will execute that device self-test program. If a device has no self-test program, this message will be displayed: No selftest method for <device name>. To run the self-test program for a device, type the `test` command followed by the device alias or device path name. An example is shown below.

```
ok test floppy
Testing floppy disk system. A formatted disk should be in the drive.
Test succeeded.
```

C.1.2 Test-all

The test-all command tests all devices in the system that have a self-test program. Tests are executed in order, using the device tree (viewed with the show-devs command) as reference. Disks, tapes, and CD-ROMs are not tested by test-all.

C.1.3 Watch-clock

This test reads a register in the NVRAM/TOD (Nonvolatile RAM/Time of Day) chip on the main logic board and displays the result as a seconds counter. The counter should count from 0 to 59 repeatedly until you interrupt it by pressing any key on the keyboard.

The following screen gives you an example of a watch-clock test.

```
ok watch-clock
Watching the 'seconds' register of the real time clock chip.
It should be 'ticking' once a second.
Type any key to stop
41
```

C.1.4 Watch-net, Watch-aui, Watch-tpe and Watch-net-all

These tests monitor broadcast Ethernet packets on the Ethernet cable(s) connected to the system. Good packets received by the system are indicated by a period (.) displayed on the screen. Errors are indicated with an X and the error description.

For example:

```
ok watch-net
  Internal loopback test -- succeeded.
  External loopback test -- Auto-selecting Ethernet cable I/F
Trying AUI
Received packet on AUI
Select cable - AUI
succeeded.
Looking for Ethernet packets.
'.' is a good packet. "X" is a bad packet.
Type any key to stop.
.....
.....Framing
error CRC error X.....
```

SPARCclassic and SPARCstation LX systems have two types of on-board Ethernet interfaces, 10BaseT (also called twisted-pair Ethernet or TPE) and 10Base5 (also called thick Ethernet or AUI). Only one on-board interface may be connected at a time. The system can automatically select which interface is connected and active.

The AUI port is first tested by transmitting packets and checking for No Carrier or response packets. If the AUI test fails, the TPE port is then tested.

Entering watch-net causes this automatic selection to take place. You may see these messages:

```
ok watch-net
  Internal loopback test -- succeeded.
  External loopback test -- Auto-selecting Ethernet cable I/F
Trying AUI
AUI Carrier Loss
Trying TPE
Received packet on TPE
Select cable - TPE
succeeded
```

You may also control the selection of Ethernet interfaces to monitor by using specific commands. Use watch-tpe to monitor the 10BaseT (TPE) connection or watch-aui to monitor the 10Base5 (thicknet) connection.

For example:

```
ok watch-tpe
  Internal loopback test -- succeeded.
  External loopback test -- succeeded.
Looking for Ethernet packets.
`.` is a good packet. `X` is a bad packet.
Type any key to stop.
.....
```

The watch-net-all command monitors Ethernet packets on any Ethernet interface installed in the system. For example, if you have an SBus Ethernet card installed in one of the system SBus slots, watch-net-all will start by monitoring Ethernet transmissions detected by that card.

When you interrupt the test on that interface by pressing any key, watch-net-all then goes on to test the next Ethernet interface it finds in the system.

For example:

```
ok watch-net-all
/iommu@f,e0000000/sbus@f,e0001000/lebuffer@1,40000/le@1,60000
  Internal loopback test -- succeeded.
  External loopback test -- succeeded.
Looking for Ethernet packets.
`.` is a good packet. `X` is a bad packet.
Type any key to stop.
.....
.....(keyboard key pressed here)

/iommu@f,e0000000/sbus@f,e0001000/ledma@f,400010/le@f,c00000
  Internal loopback test -- succeeded.
  External loopback test -- succeeded.
Looking for Ethernet packets.
`.` is a good packet. `X` is a bad packet.
Type any key to stop.
.....
.....
```

C.1.5 Probe-scsi, Probe-scsi-all

The probe-scsi test sends an inquiry command to internal and external SCSI devices connected to the system's on-board SCSI. This test is not applicable to the SPARCclassic X terminal. If a SCSI device is connected and powered up, the target address, unit number, device type, and manufacturer name should be displayed.

For example:

```
ok probe-scsi
Target 3
Unit 0 Disk SEAGATE ST1480 SUN04245828 Copyright (c) 1991 Seagate All rights
reserved.
```

The probe-scsi-all test sends an inquiry command to all SCSI devices on all the SCSI host adapters installed in the system. The first identifier listed in the display is the SCSI host adapter address in the system device tree, followed by the SCSI device identification data.

For example:

```
ok probe-scsi-all
/iommu@f,e0000000/sbus@f,e0001000/dma@1,81000/esp@1,80000
Target 2
Unit 0 Disk SEAGATE ST41600N SUN1.3G00286965 Copyright (c)1991 Seagate All
rights reserved.

/iommu@f,e0000000/sbus@f,e0001000/espdma@f,400000/esp@f,800000
Target 3
Unit 0 Disk SEAGATE ST1480 SUN04245828 Copyright (c)1991 Seagate All rights
reserved.
```

C.1.6 Test-memory

All of the system main memory will be tested if the system diag-switch? parameter is True. If the diag-switch? parameter is False, this test uses the selftest-#megs parameter in NVRAM to determine how much memory to test. The default for the selftest-#megs parameter is 1, so only 1 megabyte of memory is tested.

To change the amount of memory tested using the `selftest-#megs` parameter, type this command:

```
ok setenv selftest-#megs 16
```

This sets the desired memory size to 16 megabytes. Any whole number may be used as long as it does not exceed the actual size of memory (in megabytes) installed in the system. When the test-memory diagnostic is running, the number of megabytes being tested is displayed and counted down to zero during the test.

See the Open Boot Command Reference for a detailed description and step-by-step instructions for the available on-board diagnostic tests.

C.2 Returning to the Monitor Prompt

If you need to return to the monitor prompt from the Forth Toolkit, type `old-mode` at the `>` prompt.

```
ok old-mode  
>
```

Glossary

- AUI** Attachment Unit Interface is an Ethernet adapter cable.
- address** A location within a computer system's memory. The word *location* is a synonym. Reference is usually made to an *address* for the purpose of retrieving or storing information.
- board** See *printed circuit board*.
- boot** To load the system software into memory and start it running.
- boot PROM** The PROM chip on the main logic board. This chip contains boot code consisting of a Forth Monitor program. The boot PROM is connected to the I/O data bus.
- boot PROM diagnostics** The diagnostic firmware contained in the boot PROM. These diagnostics include the Power-On Self-Test (POST) and On-Board Diagnostics.
- cables** Wires or bundles of wires configured with connectors at each end and used to connect two or more hardware devices.
- cache** A mechanism for accelerating a microprocessor's performance. A cache is a small, fast memory between the microprocessor and main memory. It quickens a microprocessor's access time to main memory. It also stores the most recently used information (data, instructions, etc.), and provides such information again to the microprocessor more rapidly than could main memory.
- card** See *printed circuit board*.
- CPU** Central Processing Unit.
- CRU** Customer Replaceable Unit.
- Desktop Backup Pack** An external unit containing a tape drive that can be connected to a Desktop SPARCstation.
- Desktop Disk Pack** An external unit containing a disk drive that can be connected to a Desktop SPARCstation.

Desktop Storage Module	An external data storage that contains a disk drive or a tape drive.
Desktop Storage Pack (DSP)	A generic name for an external unit containing a tape drive, a disk drive, or a CD-ROM drive that can be connected to a Desktop SPARCstation. The external unit containing the tape drive is referred to as the Desktop Backup Pack. The external unit containing a disk drive is specifically referred to as the Desktop Disk Pack. The external unit containing a compact disc drive is specifically referred to as the Desktop SunCD Pack.
Desktop SunCD Pack	An external unit containing a compact disc drive.
Diagnostic Executive	See <i>SunDiagnostic Executive</i> .
disk	A round platter, or set of platters, coated with magnetic medium and organized into concentric tracks for storing data.
disk drive	The mechanism that rotates a disk.
diskette	A removable disk of magnetic medium for storing software and information. The outer jacket of the diskette is made of firm plastic that measures 3.5 inches (88.9 millimeters) across.
diskette drive	A device that reads and writes diskettes. The diskette drive access is located on the front panel of the system units. A diskette drive is optional on both SPARCclassic and SPARCstation LX systems.
DRAM	Dynamic Random Access Memory.
DSIMM	DRAM Single In-line Memory Module. A small printed circuit card that contains dynamic random access memory (DRAM) chips.
ESM	External Storage Module. An external unit that contains disk and/or tape drive(s) that can be connected to a Desktop SPARCstation.
Forth	A high-level programming language. A major feature of Forth is that user-defined operators can be used as if they are primitives.
Forth Toolkit	An interactive command interpreter based on the Forth programming language. While in the Toolkit, you will see the <code>ok</code> prompt. The Toolkit gives you access to an extensive set of functions for performing fault isolation and debugging.
frame buffer board	A printed circuit board that can be installed in an SBus slot of the system unit that controls a video display.
ID	Identification.
I/O	Input/Output. For example, an input/output device.
IU	Integer Unit.

LED	Light-Emitting Diode.
monitor (1)	Indicated by the > prompt. From the > prompt, you can boot the system, continue the execution of a halted program, or enter the Forth Toolkit. If disaster befalls your operating system, the monitor automatically starts.
monitor (2)	A video display unit that is part of a Desktop SPARCstation. It is not synonymous with the term terminal.
NVRAM	Nonvolatile RAM.
On-Board Diagnostics	A test that allows you to test the control registers, the network controller, the diskette drive system, memory, the cache, the system clock, and watch the network for valid packets.
POR	Power-On Reset TTL open collector signal from the power supply, which is activated after DC voltages have risen.
POST	Power-On Self-Test. The POST runs automatically when you turn on the system's power switch or reboot the system. The POST, stored in the boot PROM, is a series of rudimentary tests designed to verify that a viable boot path exists for loading more extensive diagnostic software, such as the Diagnostic Executive.
PTC	Positive Temperature Coefficient. A self-healing device that replaces a fuse. After an error occurs, the PTC resets.
printed circuit board	Any board with electronic wiring etched on it.
PROM	Programmable Read Only Memory.
RAM	Random Access Memory.
ROM	Read Only Memory.
SBus card	A printed circuit board installed in an SBus slot of the system unit.
SCSI	Small Computer System Interface; pronounced "scuzzy."
SunDiagnostic Executive	An independent operating system running exhaustive subsystem tests independent of SunOS. Use the SunDiagnostic Executive after you have run POST and need to troubleshoot which part needs to be replaced.
Sundiag System Exerciser	Diagnostic software that runs under SunOS; displays real-time use of system resources and peripheral equipment such as Desktop Storage Packs and External Storage Modules.
system monitor	See <i>Monitor (1) or (2)</i> .

- terminal** A device comprising a video display and keyboard that are used to type and display information. A terminal may be connected to either of the RS-232 serial interface ports on the back panel of the SPARCstation system unit. It is not synonymous with the term monitor.
- TOD** Time-of-Day clock.
- VRAM** Video Random Access Memory.
- VSIMM** VRAM Single In-line Memory Module. A small printed circuit card that contains video random access memory (VRAM) chips.
- wrist strap** A device that provides grounding for static electricity between your body and the system unit's chassis. Electric current and voltage do not pass through the wrist strap.

Index

SYMBOLS

/etc/remote, 3-5

A

access, to subassemblies, 7-1
attachment unit interface (AUI), *See* AUI
audio ports connector, B-9
AUI, C-5
autoboot switch, 2-5

B

board power supply
 connector, 4-4
 pin assignment, 4-4
 test, 4-3
boot failure, 4-1
boot PROM diagnostics, 2-1

C

cables
 external connections, 1-3
 internal connections, 1-4, 1-8, 10-4
 null modem, 3-5
 removing external, 7-1
 serial, 3-5
central processing unit (CPU) board, *See* MLB, *See*
 CPU board
closing system unit, 7-4

color frame buffer board, 1-6
connectors
 audio ports, B-9
 external
 audio line-in, B-11
 audio line-out, B-10
 internal
 diskette drive pinout, B-12
 power pinout, B-14
 SBus pinout, B-13
 parallel pinout, B-8
 SCSI (internal), B-11
 serial pinout, B-7
 type 13W3 video pinout, B-9
CPU board
 removing, 11-24
 replacing, 11-29
 test points, 11-18
 troubleshooting, 11-21
CRU (customer replaceable unit), 1-4
CRU
 identification, 10-6
 locating defective, 2-10
 main board, 1-4
 replacement, 10-1
 replacement part numbers, 12-4
 tools for replacing, 5-3

D

devices
 external, 1-1
 external storage options, 1-8

- internal, 1-4, 10-4
 - diskette drive, 1-7
 - hard disk drive, 1-7
- Diagnostic Executive, 2-10
- diagnostics
 - boot PROM, 2-1
 - default boot mode, 2-1
 - defective CRUs, 2-10
 - firmware, 2-1
 - on-board, C-1
 - SBus device probe, 2-4
 - software, 2-1
 - software and SPARCclassic X terminal, 2-1
 - tools overview, 2-2
 - tools summary, 2-7
- disk drive, *See* hard disk drive
- diskette drive, 1-7, 9-21
 - density, 1-7
 - diskette types, 1-7
 - removing, 9-22
 - replacing, 9-23
- display resolutions, 1-5
- DRAM, 1-5
- DRAM (dynamic random access memory), *See* DRAM
- drive
 - diskette, *See* diskette drive
 - hard, *See* hard disk drive
- DSIMM, 11-11
 - installing, 11-16
 - locating faulty, 4-7
 - maximum memory, 1-5
 - removing, 11-14
- dynamic random access memory (DRAM), *See* DRAM
- dynamic single in-line memory module (DSIMM), *See* DSIMM

E

- Electrical Static Discharge (ESD), *See* ESD mat
- environmental requirements, A-2
- error
 - hard disk drive, 4-6
 - read, write or parity, 4-2, 4-6
- ESD mat, 5-4
- Ethernet board, 1-6
- external devices, 1-1

F

- Forth Toolkit, 2-7
- frame buffer board, 1-6

G

- graphics I/O devices, 1-7
- grounding strap, 7-4
- GX graphics accelerator board, 1-6

H

- halting, operating system, 6-3
- hard disk drive, 1-7, 9-1
 - 207-Mbyte jumper settings, 9-4
 - 424 MB, 9-10
 - 424-Mbyte jumper settings, 9-6
 - boot failure, 4-1
 - Conner 535-Mbyte jumper settings, 9-7
 - error, 4-6
 - fails to boot, 4-6
 - mounting bracket
 - exploded view, 12-4
 - replacing bracket, 9-19
 - Seagate 1.0-Gbyte jumper settings, 9-11
 - Seagate 535-Mbyte jumper settings, 9-8
- hung system, 6-3
 - halting, 6-3

I

- input power requirements, A-1
- Input/Output (I/O) board, *See* system I/O board

J

- jumper settings
 - hard disk drive
 - verifying, 9-4
 - SCSI settings, 9-3

K

- keyboard LED, 3-8

L

light emitting diode (LED), 8-4

M

main logic board (MLB), *See* MLB

memory, 1-5

- address ranges, 4-8

- configuration, 1-5

- error reporting, 4-7

- location "U" number, 4-7

- maximum, 1-5

- physical address, 4-7

- slot arrangement, 4-8

MLB

- customer replaceable units (CRUs), 1-4

- removing, 8-9, 11-24

- replacing, 8-12, 11-29

- SPARCclassic and X terminal, 10-4

- SPARCstation LX, 10-5 to 10-6

- test, 4-5

- test points, 11-18

- troubleshooting, 11-21

monitor, 1-7

mounting bracket

- exploded view, 12-4

N

NVRAM (nonvolatile random access memory), *See*

- NVRAM

null modem cable, 3-5

NVRAM

- open boot commands, 1-6

- parameters, 2-4

O

On-Board Diagnostics, C-1

on-board test

- disk0, 2-8

- floppy, 2-8

- net, 2-8

- net-aui, 2-8

- net-tpe, 2-8

- screen, 2-8

- scsi, 2-8

- tape0, 2-9

- ttya, 2-9

- ttyb, 2-9

- opening, system unit, 7-2

- operating system, halting, 6-3

- options, 1-7

P

part numbers

- listing, 12-4

- related documentation, 12-7

physical specifications, A-3

pin assignment, B-1

- audio ports, B-9

- board power supply

 - connector, 4-4

- diskette drive connector, B-12

- parallel connector, B-8

- power supply (internal), B-14

- SBus connector (internal), B-13

- SCSI (external), B-6

- SCSI (internal), B-11

- serial, B-7

- type 13W3 video connector, B-9

POST overview, 2-4

power

- turning off, 6-2, 6-4

- turning on, 6-4

power on, fails, 4-2

power supply

- external devices, 1-7

- features, 1-7

- voltage, 1-7

- wattage, 1-7

powering on the system, 6-4

Power-On Self Test (POST), 2-4, 3-1

probe-scsi, 4-6, C-7

probe-scsi-all, C-7

R

rear panel, cables, 7-1

regulatory compliance information, A-3

related books, xvii

replacing CRUs, tools needed, 5-3

- requirements
 - environmental, A-2
 - input power, A-1

S

- safety precautions (table), 10-3
- SBus
 - boards, 1-5
 - cards, 1-5
 - options, 1-6
 - printer board, 1-6
 - slots, 1-5
- SCSI
 - disconnecting, cable, 7-1
 - factory address setting, 9-4
 - ID jumper location, 9-4
 - verifying a defective controller, 4-6
- serial cable, 3-5
- speaker, replacing, 8-4, 8-6
- specifications, physical, A-3
- SunDiagnostic Executive, 2-10
- system
 - abnormal response, 6-3
 - closing, 7-4
 - differences, 1-2
 - front panel, 1-1
 - I/O board
 - removing
 - replacing, 8-12
 - opening, 7-2
 - rear panel, 1-1
 - subassembly access, 7-1
- system components, 1-1
- system I/O board
 - location, 8-7
 - removing, 8-7
- system overviews
 - SPARCclassic, 1-1
 - SPARCclassic X, 1-1
 - SPARCstation LX, 1-1
- system power supply, location, 8-1

T

- test, C-3
 - MLB, 4-5

- power supply, 4-3
- test points, 11-18
- test<*device path*>, C-3
- test-all, C-3, C-4
- test-memory, C-7
- thick Ethernet, C-5
- tip, 3-5
- tip window, 3-5
- tools needed to replace CRUs, 5-3
- troubleshooting, 2-1
- turning off power, 6-2, 6-4
- twisted pair Ethernet (TPE), C-5

U

- unit illustration
 - bottom, 12-3
 - top, 12-2

V

- video connectors, *See* connectors
- video display resolutions, 1-5
- Video Frame Capture Board, 1-6
- video output, none, 4-2
- video single in-line memory module (VSIMM), *See* VSIMM
- VSIMM
 - installing, 11-9
 - resolutions supported, 1-5

W

- watch-aii, C-4
- watch-clock, C-4
- watch-net, C-4
- watch-net-all, C-4
- watch-tpe, C-4
- wrist strap
 - attaching, 7-4
 - detaching, 7-4